

IMPORTANT NOTICES

FOR RECREATIONAL OFF-ROAD OR COMPETITION USE ONLY

This motorcycle is designed and manufactured for recreational off-road use or competition only and is covered by noise control warranty. It does not conform to federal motor vehicle safety standards or US EPA On Highway Exhaust Emission regulations, and operation on public streets, roads, or highways is illegal. The vehicle is equipped with a USDA qualified spark arrester. If you need to cross a paved or public road, get off and walk your motorcycle across.

Do not modify any emission-related items except for competition use. Any emission-related modifications should be restored to standard factory specifications before resuming recreational off-road use.

NO PASSENGERS

This motorcycle is designed and constructed as an operator-only model. The motorcycle load limit and seating configuration do not safety permit the carrying of a passenger.

This manual should be considered a permanent part of the motorcycle and should remain with the motorcycle when it is resold.

All information in this publication is based on the latest product information available at the time of approval for printing. Honda Motor Co., Ltd. reserves the right to make changes at any time without notice and without incurring any obligation.

No part of this publication may be reproduced without written permission.

The vehicle pictured on the front cover may not match your vehicle.

**2007
Honda CRF250X
OWNER'S MANUAL & COMPETITION HANDBOOK**

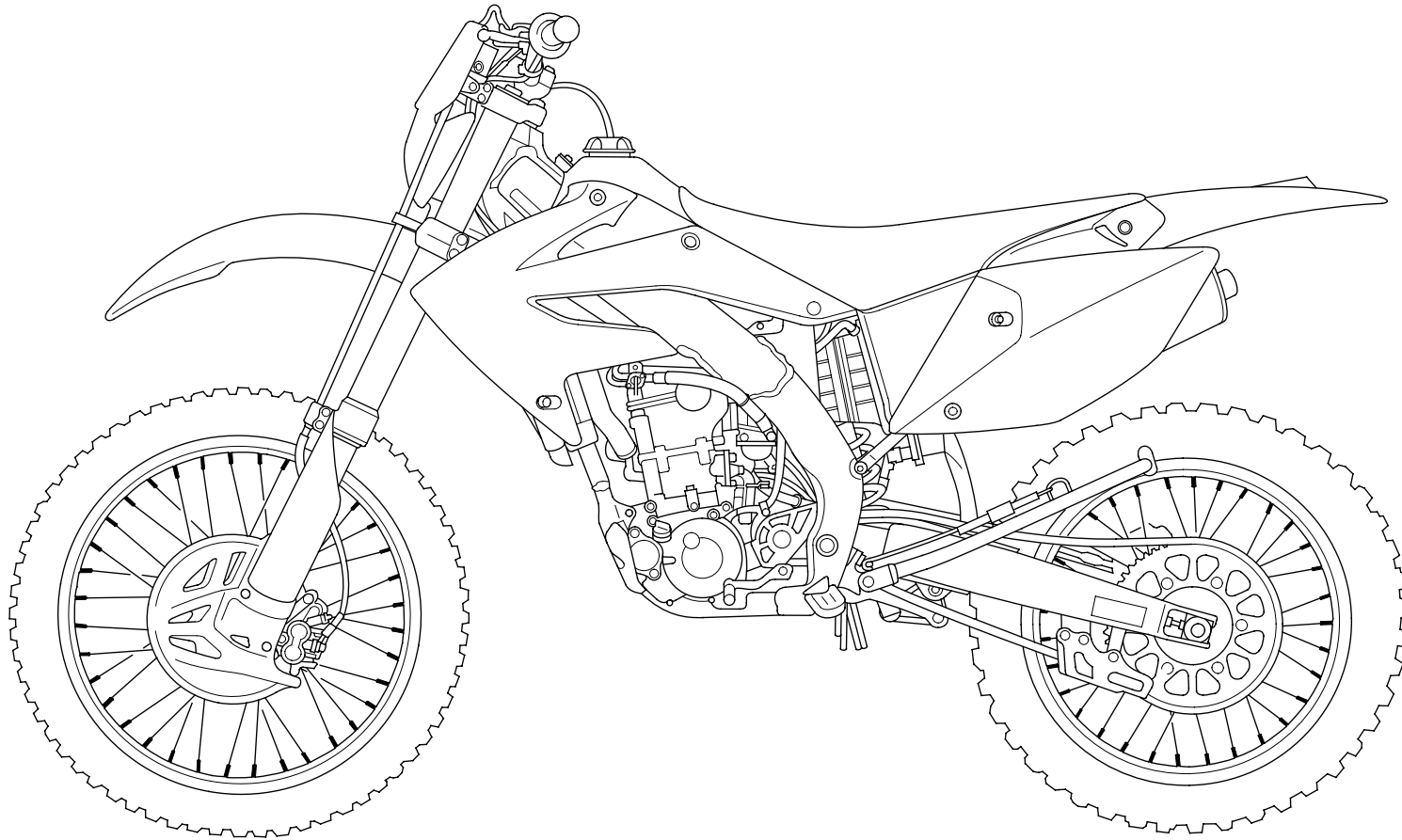

FOR OFF-ROAD USE ONLY

This vehicle is designed and manufactured for off-road use only.

USA only:

If conforms to US EPA Noise Emission regulations, but does not conform to Federal Motor Vehicle Safety Standards or US EPA On Highway Exhaust Emission regulations, and operation on public streets, roads, or highways is illegal. The vehicle is equipped with a USDA qualified spark arrester. Obey local laws and regulations.

It conforms to US EPA and California exhaust emission regulations for off-road motorcycles.

Introduction

Congratulations on choosing your Honda CRF off-road motorcycle.

When you own a Honda, you're part of a worldwide family of satisfied customers-people who appreciate Honda's reputation for building quality into every product.

Your Honda was designed as a recreational CRF for off-road use by one rider only.

Before riding, take time to get acquainted with your motorcycle and how it works. To protect your investment, we urge you to take responsibility for keeping your CRF well maintained. Scheduled service is a must, of course. But it's just as important to observe the break-in guidelines, and perform all the pre-ride and other periodic checks detailed in this manual.

You should also read the owner's manual before you ride. It's full of facts, instructions, safety information, and helpful tips. To make it easy to use, the manual contains a table of contents, a detailed list of topics at the beginning of each section, and an index at the back of the book.

As you read this manual, you will find information that is preceded by a **NOTICE** symbol. This information is intended to help you avoid damage to your Honda, other property, or the environment.

Unless you are mechanically qualified and have the proper tools, you should see your Honda dealer for the service and adjustment procedures discussed in this manual.

The official Honda Service Manual for your CRF is available (page 168). It is the same manual your dealer uses. If you plan to do any service on your CRF beyond the standard maintenance procedures in this manual, you will find the Service Manual a valuable reference.

Read the Warranties Booklet (page 169) thoroughly so you understand the coverages that protect your new Honda and are aware of your rights and responsibilities.

This motorcycle has no cooling fan. For this reason, engine overheating and coolant loss will occur if the engine is kept idling too long when hot. Additionally, when riding in mud or sand, or any condition that causes high engine load at low vehicle speed, the time it takes for the engine to overheat will be shortened, especially when the ambient temperature is high. Continuing to operate the unit in these conditions will result in engine damage.

An optional cooling fan is available and is recommended for units that will be operated in conditions with high engine load and low vehicle speed.

Whenever you ride, tread lightly. By staying on established trails and riding only in approved areas, you help protect the environment and keep off-road riding areas open for the future.

If you have any questions, or if you ever need a special service or repairs, remember that your Honda dealer knows your CRF best and is dedicated to your complete satisfaction.

Please report any change of address or ownership to your Honda dealer so we will be able to contact you concerning important production information.

You may also want to visit our website at www.honda.com

Happy riding!

California Proposition 65 Warning

WARNING: This product contains or emits chemicals known to the State of California to cause cancer and birth defects or other reproductive harm.

A Few Words About Safety

Your safety, and the safety of others, is very important. And operating this motorcycle safely is an important responsibility.

To help you make informed decisions about safety, we have provided operating procedures and other information on labels and in this manual. This information alerts you to potential hazards that could hurt you or others.

Of course, it is not practical or possible to warn you about all hazards associated with operating or maintaining a motorcycle. You must use your own good judgment.

You will find important safety information in a variety of forms, including:

- **Safety Labels** — on the motorcycle.
- **Safety Messages** — preceded by a safety alert symbol  and one of three signal words: **DANGER**, **WARNING**, or **CAUTION**.

These signal words mean:

 **DANGER**

You **WILL** be **KILLED** or **SERIOUSLY HURT** if you don't follow instructions.

 **WARNING**

You **CAN** be **KILLED** or **SERIOUSLY HURT** if you don't follow instructions.

 **CAUTION**

You **CAN** be **HURT** if you don't follow instructions.

- **Safety Headings** — such as Important Safety Reminders or Important Safety Precautions.
- **Safety Section** — such as Motorcycle Safety.
- **Instructions** — how to use this motorcycle correctly and safely.

This entire book is filled with important safety information— please read it carefully.

Contents

MOTORCYCLE SAFETY.....1	<i>Service Procedures</i>	Tire Selection for Track Conditions.....137
Important Safety Information.....2	<u>Fluids & Filters</u>	Personal Fit Adjustments138
Important Safety Precautions.....2	Fuel System.....41	
Loading.....3	Engine Oil43	TIPS139
Accessories & Modifications4	Transmission Oil46	Transporting Your Motorcycle140
Safety Labels.....5	Coolant48	Storing Your Honda.....141
	Air Cleaner.....51	You & the Environment143
OPERATING CONTROLS7	Crankcase Breather53	Troubleshooting.....144
Operation Component Locations8		
	<u>Engine</u>	TAKING CARE OF THE
BEFORE RIDING9	Throttle54	UNEXPECTED145
Are You Ready to Ride?10	Clutch System56	If a Fuse Blows146
Is Your Motorcycle Ready to Ride?.....11	Hot Start Lever.....60	If Your Battery Is Low (or Dead).....147
Pre-ride Inspection11	Spark Plug61	
	Exhaust Pipe/Muffler62	TECHNICAL INFORMATION149
BASIC OPERATING INSTRUCTIONS13	Spark Arrester.....65	Vehicle Identification150
Safe Riding Precautions.....14	Valve Clearance.....66	Specifications151
Starting & Stopping the Engine15	Piston/Piston Rings/Piston Pin.....74	Torque Specifications.....154
Shifting Gears.....17		High Altitude Carburetor Adjustment157
Braking.....18	<u>Chassis</u>	Emission Control Systems158
Parking19	Suspension.....82	Oxygenated Fuels.....160
Post-ride Inspection.....20	Brakes.....86	Competition Logbook161
Break-in Guidelines21	Wheels.....90	Optional Parts List163
	Tires & Tubes.....91	Spare Parts & Equipment.....164
SERVICING YOUR HONDA.....23	Side Stand.....93	Wiring Diagram.....165
<i>Before You Service Your Honda</i>	Drive Chain.....94	
The Importance of Maintenance24	Additional Maintenance Procedures97	CONSUMER INFORMATION167
Maintenance Safety25		Authorized Manuals168
Important Safety Precautions.....25	<u>Electrical</u>	Warranty Coverage.....169
Maintenance Schedule26	Battery99	Warranty Service170
General Competition Maintenance29	Headlight & Taillight101	Contacting Honda.....171
Before & After Competition Maintenance.....33	Appearance Care102	Your Honda Dealer.....172
Between Motos & Practice Maintenance33		The Honda Rider's Club (USA only)173
After Competition Maintenance33	ADJUSTMENTS FOR COMPETITION ...105	
<i>Service Preparations</i>	Front Suspension Adjustments.....106	TABLE OF CONTENTS174
Maintenance Component Locations.....35	Rear Suspension Adjustments.....120	
Seat Removal36	Suspension Adjustments for Track	INDEX176
Fuel Tank Removal37	Conditions124	
Subframe Upright Position.....39	Suspension Adjustment Guidelines.....125	QUICK REFERENCE
	Carburetor Adjustment & Turning Tips128	
	Chassis Adjustments.....135	
	Gearing136	

This section presents some of the most important information and recommendations to help you ride your CRF safely. Please take a few moments to read these pages. This section also includes information about the location of safety labels on your CRF.

Important Safety Information.....	2
Important Safety Precautions.....	2
Loading.....	3
Accessories & Modifications	4
Safety Labels	5

Important Safety Information

Important Safety Precautions

Your CRF can provide many years of pleasure, if you take responsibility for your own safety and understand the challenges you can meet in competitive racing.

There is much that you can do to protect yourself when you ride. You'll find many helpful recommendations throughout this manual. The following are a few that we consider most important.

Always Wear a Helmet. It's a proven fact: helmets significantly reduce the number and severity of head injuries. So always wear an approved motorcycle helmet. We also recommend that you wear eye protection, sturdy boots, gloves, and other protective gear.

Never Carry a Passenger. Your CRF is designed for one person only. There are no handholds, footrests, or seat for a second person—so never carry a passenger. A passenger could interfere with your ability to move around to maintain your balance and control of the motorcycle.

Ride Off-Road Only. Your CRF is designed and manufactured for off-road use only. The tires are not made for pavement, and the CRF does not have turn signals and other features required for use on public roads. If you need to cross a paved or public road, get off and walk your CRF across.

Always Wear Protective Gear. We recommend that you wear sturdy boots, gloves, and other protective gear. The exhaust system becomes very hot during operation, and it remains hot after operation. Never touch any part of the hot exhaust system. Wear clothing that fully covers your legs.

Do not wear loose clothing which could catch on the control levers, kickstarter, footpegs, drive chain, or wheels.

Take Time to Learn and Practice. Developing off-road riding skills is a gradual, step-by-step process. Start by practicing at low speed in a safe area and slowly build your skills. Personal instruction from an experienced rider can also be valuable.

If you need assistance, ask your dealer about riding groups in your area.

Also be sure to read the *Tips & Practice Guide for the Off-Highway Motorcyclist* booklet that came with your CRF (USA only).

Be Alert for Off-Road Hazards. The terrain can present a variety of challenges when you ride off-road. Continually “read” the terrain for unexpected turns, drop-offs, rocks, ruts, and other hazards. Always keep your speed low enough to allow time to see and react to hazards.

Ride within Your Limits. Pushing limits is another major cause of motorcycle accidents. Never ride beyond your personal abilities or faster than conditions warrant. Remember that alcohol, drugs, fatigue, and inattention can significantly reduce your ability to make good judgments and ride safety.

Don't Drink and Ride. Alcohol and riding don't mix. Even one drink can reduce your ability to respond to changing conditions, and your reaction time gets worse with every additional drink. So don't drink and ride, and don't let your friends drink and ride either.

Keep Your Honda In Safe Condition. It's important to keep your CRF properly maintained and in safe riding condition. Having a breakdown can be difficult, especially if you are stranded off-road far from your base. To help avoid problems, inspect your CRF before every ride and perform all recommended maintenance.

Your CRF was designed as a rider-only motorcycle. It was not designed to carry a passenger or cargo. A passenger or cargo could interfere with your ability to move around to maintain your balance and control of the CRF.

In addition, exceeding the weight limits or carrying an unbalanced load can seriously affect your CRF's handling, braking, and stability. Adding accessories or making modifications that change this CRF's design and performance can also make it unsafe. Also, the weight of any accessories will reduce the maximum load the motorcycle can carry.

More specific information on load limits, accessories, and modifications follows.

Loading

How much weight you put on your CRF, and how you load it, are important to your safety. If you decide to carry cargo, you should be aware of the following information.

WARNING

Overloading or carrying a passenger can cause a crash and you can be seriously hurt or killed.

Follow all loading guidelines in this manual.

Loading Guidelines

As discussed on page 2, we recommended that you do not carry any cargo on this motorcycle. However, if you decide to carry cargo, ride at reduced speeds and follow these commonsense guidelines:

- Keep cargo small and light. Make sure it cannot easily be caught on brush or other objects, and that it does not interfere with your ability to shift position to maintain balance and stability.
- Place weight as close to the center of the motorcycle as possible.
- Do not attach large or heavy items (such as a sleeping bag or tent) to the handlebar, fork, or front fender.
- Check that both tires are inflated properly.

Accessories & Modifications

Accessories & Modifications

Modifying your CRF or using non-Honda accessories can make your CRF unsafe.

Before you consider making any modifications or adding an accessory, be sure to read the following information.

⚠ WARNING

Improper accessories or modifications can cause a crash in which you can be seriously hurt or killed.

Follow all instructions in this owner's manual regarding modifications and accessories.

Accessories

We strongly recommend that you use only genuine Honda accessories that have been specifically designed and tested for your CRF. Because Honda cannot test all other accessories, you must be personally responsible for proper selection, installation, and use of non-Honda accessories. Check with your dealer for assistance and always follow this guideline:

- Make sure the accessory does not reduce ground clearance and lean angle, limit suspension travel or steering travel, alter your riding position, or interfere with operating any controls.

Modifications

We strongly advise you not to remove any original equipment or modify your CRF in any way that would change its design or operation. Such changes could seriously impair your CRF's handling, stability, and braking, making it unsafe to ride.

We also advise you not to make any modifications or remove any equipment (such as the USDA qualified spark arrester or emission control system components) that would make the motorcycle illegal in your area.

This page shows the locations of safety labels on your CRF. Some labels warn you of potential hazards that could cause serious injury. Others provide important safety information. Read these labels carefully and don't remove them.

If the label comes off or becomes hard to read, contact your Honda dealer for replacement.

IMPORTANT INFORMATION
This vehicle is designed and manufactured for off road use only. It does not conform to Federal motor vehicle safety standards and operation on public streets, roads, or highways is illegal.
For your protection, always wear your helmet while riding.
Operator only. No passengers.
Read the owner's manual carefully.
This Honda motorcycle is sold as is without warranty and the entire risk as to quality and performance is with the buyer.

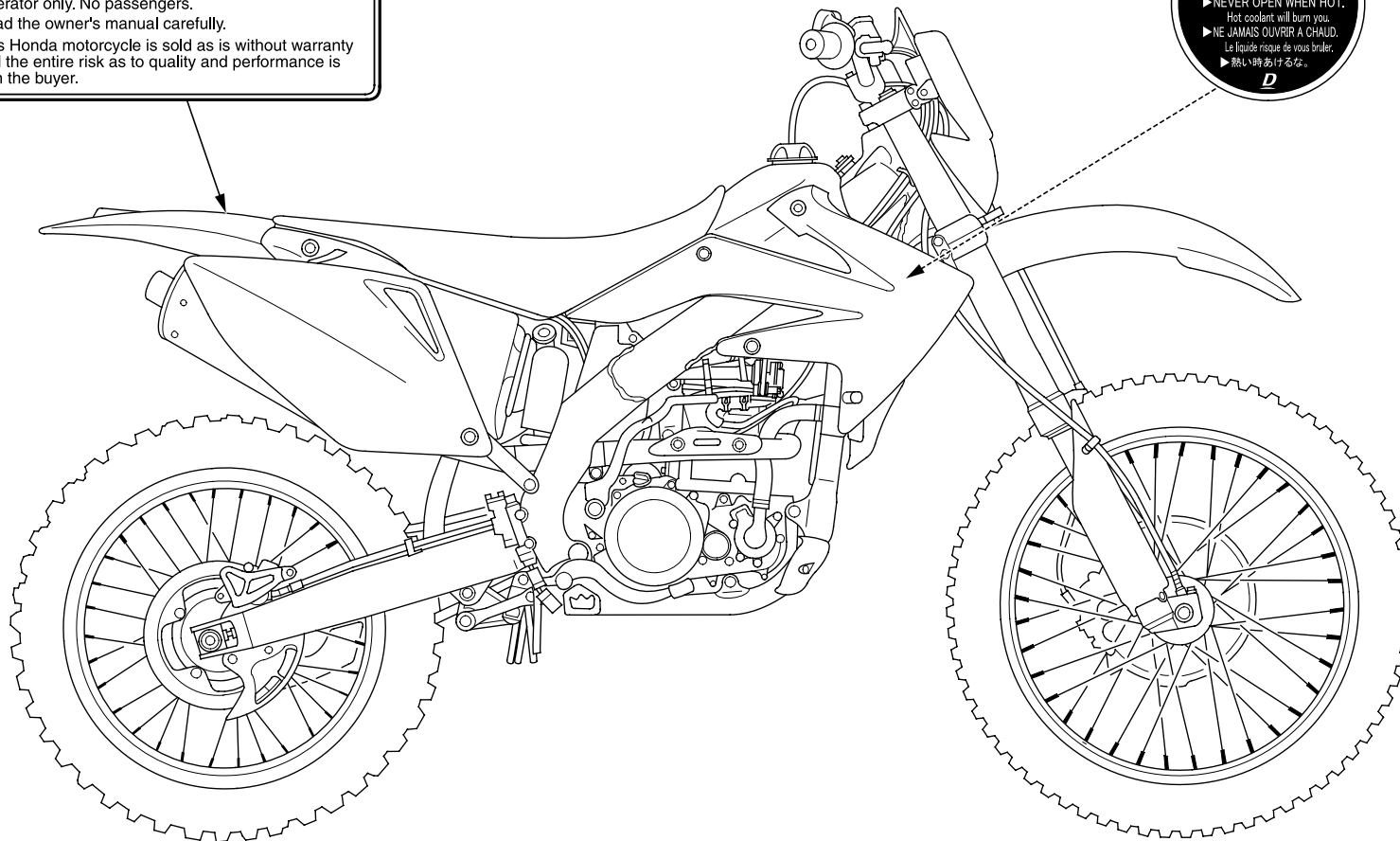

Read this section carefully before you ride. It presents the location of the basic controls on your CRF.

Operation Component Locations8

Operation Component Locations

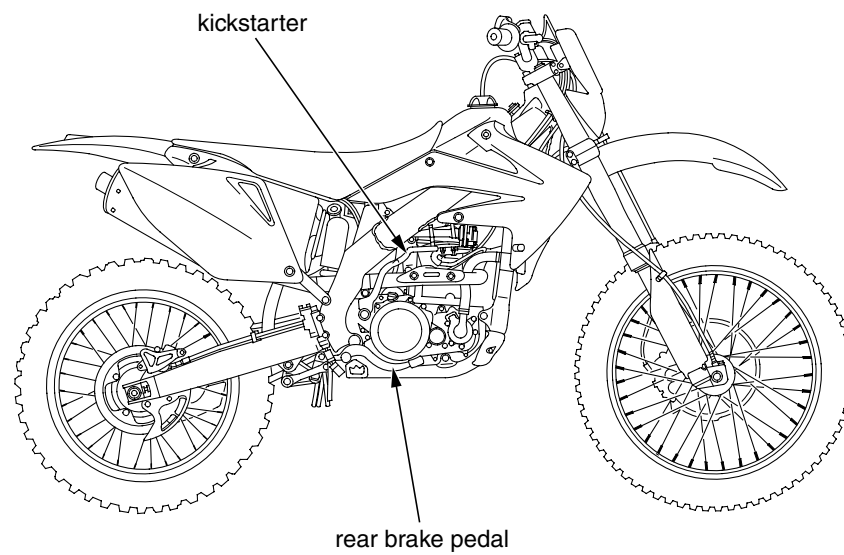
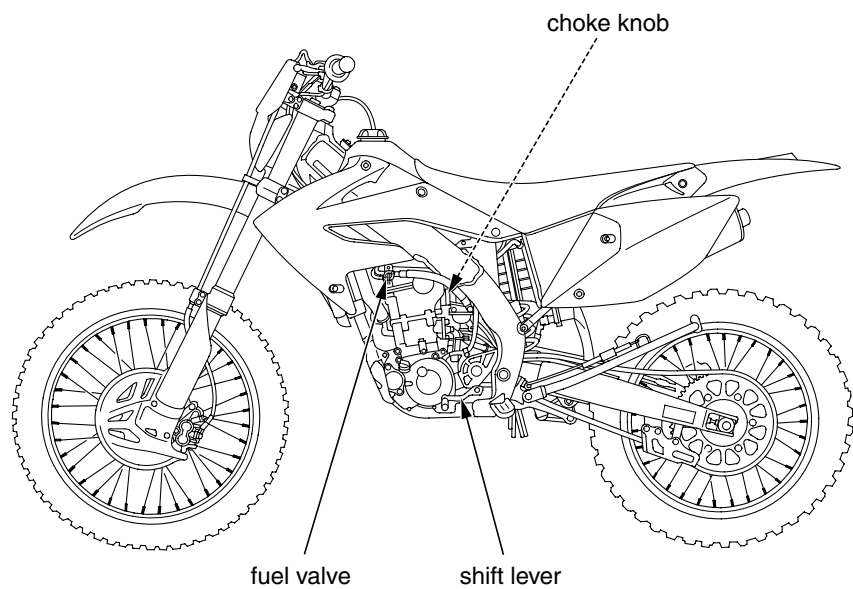
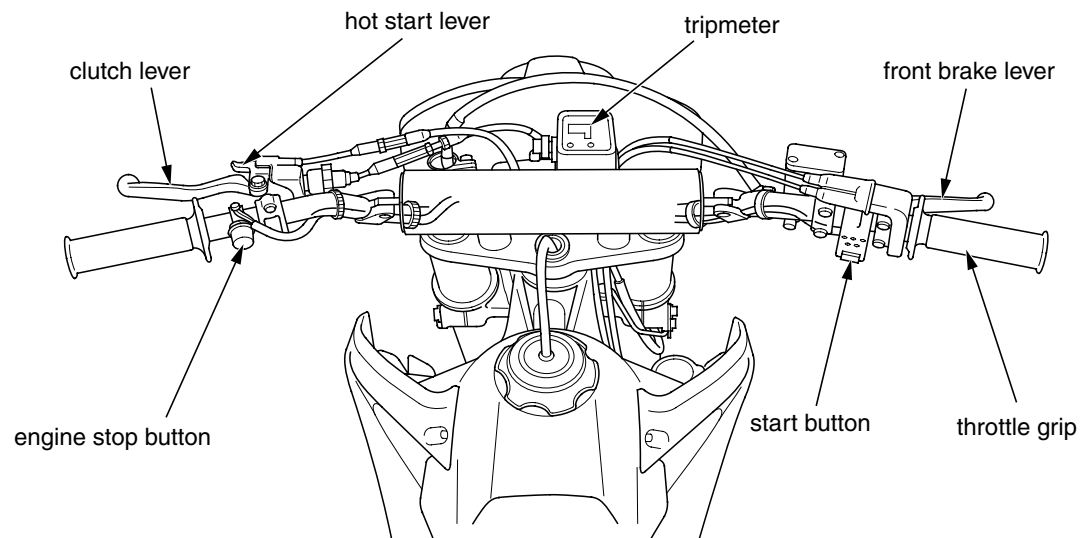

Before each ride, you need to make sure you and your Honda are both ready to ride. To help get you prepared, this section discusses how to evaluate your riding readiness, and what items you should check on your CRF.

For information about suspension, carburetor and other adjustment for competition see page 105.

Are You Ready to Ride?.....	10
Is Your Motorcycle Ready to Ride?.....	11
Pre-ride Inspection	11

Are You Ready to Ride?

Before riding your CRF for the first time, we recommend that you read this owner's manual, make sure you understand the safety messages, and know how to operate the controls.

Before each ride, it's also important to make sure you and your CRF are both ready to ride.

For information about suspension, carburetor, and other adjustments, see page 105.

Whether you're preparing for competition or for practice, always make sure you are.

- In good physical and mental condition
- Free of alcohol and drugs
- Wearing an approved helmet, eye protection, and other appropriate riding gear

Although complete protection is not possible, wearing the proper gear can reduce the chance or severity of injury when you ride.

WARNING

Not wearing a helmet increases the chance of serious injury or death in a crash.

Be sure you always wear a helmet, eye protection and other protective apparel when you ride.

Competitive riding can be tough on a motorcycle, so it's important to inspect your CRF and correct any problems you find before each ride. Check the following items (page numbers are at the right):

⚠ WARNING

Improperly maintaining this motorcycle or failing to correct a problem before riding can cause a crash in which you can be seriously hurt or killed.

Always perform a pre-ride inspection before every ride and correct any problems.

Pre-ride Inspection

Check the following before each ride:

- Engine oil level44
- Transmission oil level47
- Coolant for proper level48
- Cooling system and hoses for condition49
- Spark plug for proper heat range, carbon fouling and direct ignition coil connector for looseness61
- Air cleaner for condition and contamination51
- Clutch operation and freeplay56
- Hot start lever freeplay60
- Breather drain for cleaning53
- Steering head bearings and related parts for condition97
- Carburetor throttle operation55
- Engine idle speed for stable and proper RPM134
- Tires for damage or improper inflation pressure91
- Spokes for looseness90
- Rim locks for looseness90
- Front and rear suspension for proper operation82,83
- Front and rear brakes, check operation87
- Drive chain for wear or damage and adequate lubrication94
- Drive chain guide, sliders and guide rollers for damage or wear96
- Exhaust pipe/Muffler inspection62
- Every possible part for looseness (such as cylinder head nuts, engine mounting bolts, axle nuts, handlebar holder bolts, fork bridge pinch bolts, drive chain adjuster, drive chain guide, wire harness connectors, kickstarter mounting bolt, etc.)98,154-156

This section gives basic information on how to start and stop your engine as well as break-in guidelines.

Safe Riding Precautions.....	14
Side Stand	14
Tripmeter.....	14
Starting & Stopping the Engine	15
Preparation	15
Fuel Valve	15
Starting Procedure	15
Flooded Engine	16
How to Stop the Engine.....	16
Shifting Gears.....	17
Braking	18
Parking	19
Post-ride Inspection.....	20
Break-in Guidelines	21

Basic Operating Instructions

Safe Riding Precautions

Before riding your CRF for the first time, please review the *Important Safety Precautions* beginning on page 2 and the previous section, titled *Before Riding*.

For your safety, avoid starting or operating the engine in an enclosed area such as a garage. Your CRF's exhaust contains poisonous carbon monoxide gas which can collect rapidly in an enclosed area and cause illness or death.

Side Stand

The side stand (1) is used to support your CRF while parked (page 19). To operate, use your foot to lower the side stand until it is fully extended. Before riding, raise the side stand.

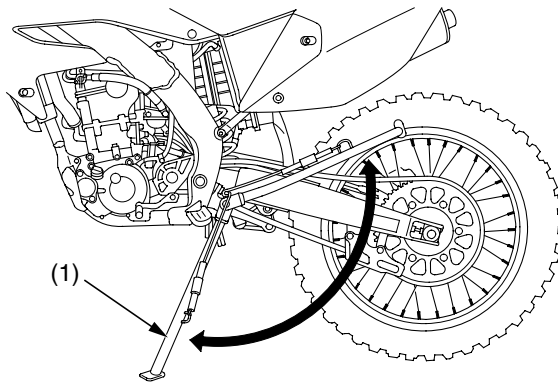

(1) side stand

Tripmeter

The tripmeter (1) is used to record the distance traveled (USA: miles, Canada: kilometers) per trip or section of route.

To operate, pull the tripmeter reset knob (2) out (OFF) and turn it until the meter shows all zeros (0), then push the knob in (ON).

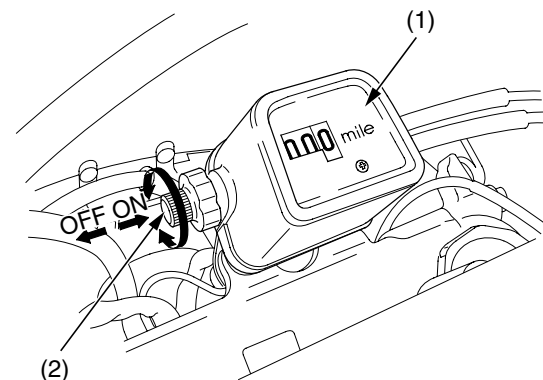

(1) tripmeter
(2) tripmeter reset knob

Always follow the proper starting procedure described below.

Your CRF can be started with the transmission in gear by pulling in the clutch lever before operating the kickstarter or start button.

Preparation

Make sure that the transmission is in neutral. Turn the fuel valve ON.

Fuel Valve

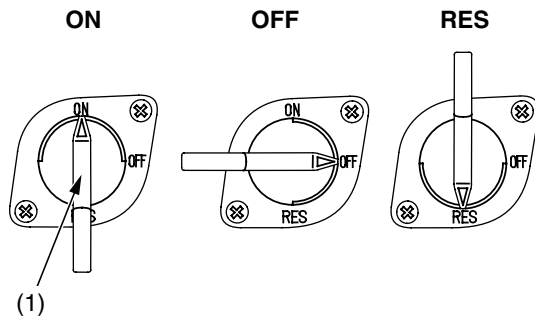

(1) fuel valve

The three-way fuel valve is used to control the flow of fuel from the fuel tank to the carburetor.

ON—Turning the fuel valve ON before attempting to start the engine allows fuel to flow from the fuel tank to the carburetor.

OFF—Turning the fuel valve OFF prevents the flow of fuel from the fuel tank to the carburetor.

RES—Turning the fuel valve to RES allows fuel to flow from the reserve fuel supply to the carburetor.

Starting Procedure

Always follow the proper starting procedure described as follow.

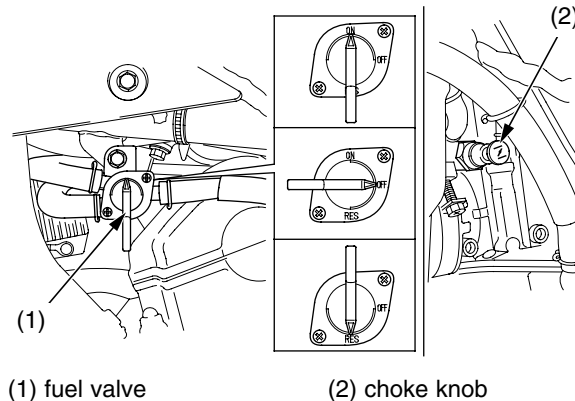

(1) fuel valve

(2) choke knob

Check the engine oil, transmission oil and coolant levels before starting the engine (pages 44,47,48).

To restart a warm engine, follow the procedure for “High Air Temperature.”

Normal Air Temperature 10°C-35°C (50°F-95°F)

1. Turn the fuel valve (1) ON.
2. Pull the choke knob (2) fully ON, if the engine is cold.
3. Keep the throttle fully closed.
4. Pull the clutch lever all the way in, and depress the start button. Or operate the kickstarter to start the engine. Starting from the top of the stroke, kick through to the bottom with a rapid, continuous motion. Do not operate the throttle.

NOTICE

Allowing the kickstarter to snap back freely against the pedal stop can damage the engine case.

5. Warm up the engine; don't operate the throttle.
6. About 15 seconds after the engine starts, push the choke knob all the way to fully OFF. If idling is unstable, open the throttle slightly.

NOTICE

Extended use of the choke may impair piston and cylinder wall lubrication and damage the engine.

High Air Temperature 35°C (95°F) or above

1. Do not use the choke.
2. Keep the throttle fully closed.
3. Start the engine following step 4 under “Normal Air Temperature”.

Low Air Temperature 10°C (50°F) or below

1. Follow steps 1-4 under “Normal Air Temperature”.
2. Continue warming up the engine until it runs smoothly and responds to the throttle when the choke knob is pushed back all the way to fully OFF.

NOTICE

Extended use of the choke may impair piston and cylinder wall lubrication and damage the engine.

Hot Engine Starting

1. Pull the hot start lever (3) all the way in and start the engine following step 4 under “Normal Air Temperature”.
2. As soon as the engine starts, release the hot start lever.

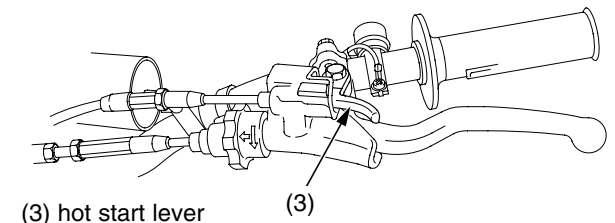

(3) hot start lever

Starting & Stopping the Engine

Flooded Engine

Starting the engine after a stall during riding or after a fall:

1. Shift the transmission into neutral.
2. Pull the hot start lever all the way in and start the engine.
(Do not open the throttle).
3. As soon as the engine starts, release the hot start lever.

Starting a flooded engine:

(Using the start button)

1. Do not use the choke.
2. Shift the transmission into neutral with the throttle fully opened.
3. Pull the hot start lever and clutch lever all the way in and depress the start button for 5 seconds.
If the engine starts, quickly close the throttle, then open it slightly if idling is unstable. If the engine does not start, wait 10 seconds, and then follow the regular starting procedure.
4. As soon as the engine starts, release the hot start lever.

(Using the kickstarter)

1. Do not use the choke.
2. Shift the transmission into neutral with the throttle fully opened, repeat kickstarter operation approximately ten times very slowly to discharge excessive fuel from the engine. Close the throttle.
3. Pull the hot start lever all the way in and start the engine (Do not open the throttle.)
4. As soon as the engine starts, release the hot start lever.

How to Stop the Engine

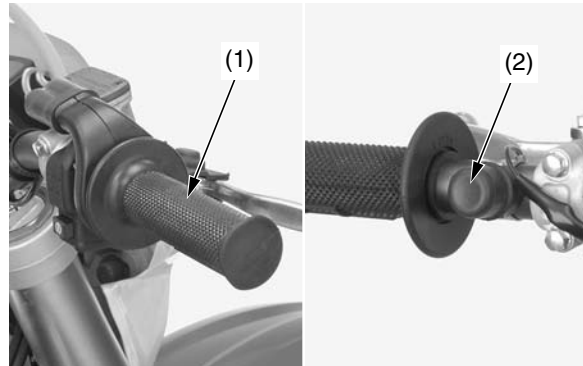

(1) throttle

(2) engine stop button

Normal Engine Stop

1. Shift the transmission into neutral.
2. Turn the fuel valve OFF.
3. Lightly open the throttle (1) two or three times, and then close it.
4. Depress and hold the engine stop button (2) until the engine stops completely.

Failure to close the fuel valve may cause the carburetor to overflow, result in hard starting.

Emergency Engine Stop

To stop the engine in an emergency, depress and hold the engine stop button.

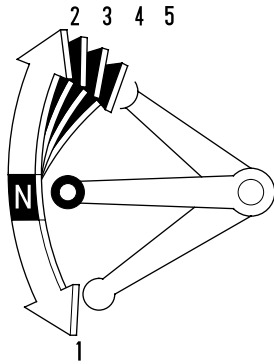

Your CRF has five forward gears in a one-down, four-up shift pattern.

To start riding, after the engine has been warmed and the side stand raised.

1. Close the throttle and pull the front brake lever in.
2. Pull the clutch lever all the way in.
3. Depress the shift lever from neutral down to first gear.
4. Release the front brake. Gradually open the throttle while you slowly release the clutch lever. If the engine rpm (speed) is too low when you release the clutch lever, the engine will stall.

If the engine rpm (speed) is too high or you release the clutch lever too quickly, your CRF may lurch forward.

5. When you attain a moderate speed, close the throttle, pull the clutch lever in, and raise the shift lever. After shifting, release the clutch lever and apply the throttle.
6. To continue shifting up to each higher gear, repeat step 5.
7. To shift down to a lower gear, close the throttle, pull the clutch lever in, and depress the shift lever. After shifting, release the clutch lever and apply the throttle.

Remember to close the throttle and pull the clutch lever in completely before shifting.

NOTICE

Improper shifting may damage the engine, transmission, and drive train.

Learning when to shift gears comes with experience. Upshift to a higher gear or reduce throttle before engine rpm (speed) gets too high. Downshift to a lower gear before you feel the engine laboring (lugging) at low rpm.

NOTICE

Downshifting can help slow your motorcycle, especially on downhills. However, downshifting when engine rpm is too high can cause engine damage.

NOTICE

To prevent transmission damage, do not coast or tow the motorcycle for long distances with the engine off.

Braking

To slow or stop, apply the front brake lever and rear brake pedal smoothly, while downshifting to match your speed. Gradually increase braking as you feel the brakes slowing your speed. To prevent stalling the engine, pull the clutch lever in before coming to a complete stop. For support, put your left foot down first, then your right foot when you are through using the rear brake pedal.

For maximum braking, close the throttle and firmly apply the front brake lever and rear brake pedal controls.

Applying the brakes too hard may cause the wheels to lock and slide, reducing control of your CRF. If this happens, release the brake controls, steer straight ahead until you regain control, then reapply the brakes more gently.

Generally, reduce your speed or complete braking before beginning a turn. Avoid braking or closing the throttle quickly while turning. Either action may cause one or both wheels to slip. Any wheel slip will reduce your control of your CRF.

When riding in wet or raining conditions, or on loose surfaces, the ability to maneuver and stop will be reduced. All of your actions should be smooth under these conditions. Rapid acceleration, braking, or turning may cause loss of control. For your safety, exercise extreme caution when braking, accelerating, or turning.

When descending a long, steep grade, use engine compression braking by downshifting, with intermittent use of both brakes.

When you brake to a stop, pull the clutch lever in before stopping completely to prevent stalling the engine. For support, put your left foot on the ground first, then your right foot when you're through braking.

Lower the side stand to support your CRF.
If you're through riding for the day, turn the fuel valve OFF. Always choose a level surface to park.

Post-ride Inspection

When you return home after riding, thoroughly clean your CRF and remove any dirt, mud, brush, rocks or other objects you may have picked up along the way.

After cleaning, carefully inspect your CRF for leaks or damage.

Be sure to lubricate the drive chain (page 96) to prevent rusting.

Help assure your CRF's future reliability and performance by paying extra attention to how you ride during the first operating day or 15 miles (25 km).

During this period, avoid full-throttle starts and rapid acceleration.

This same procedure should be followed each time when:

- piston is replaced
- piston rings are replaced
- cylinder is replaced
- crankshaft or crank bearings are replaced

Keeping your CRF well maintained is absolutely essential to your safety. It's also a good way to protect your investment, get maximum performance, avoid breakdowns, and have more fun.

To help keep your CRF in good shape, this section includes a Maintenance Schedule for required servicing and step-by-step instructions for specific maintenance tasks. You'll also find important safety precautions, information on oils, and tips for keeping your Honda looking good.

The ICM (Ignition Control Module) system is used on this motorcycle; consequently, routine ignition timing adjustment is unnecessary. If you want to check the ignition timing, refer to the Honda Service Manual (page 168).

For information about the exhaust emission and noise emission requirements of the U.S. Environmental Protection Agency (EPA) and the California Air Resources Board (CARB), see page 158.

USA only

Maintenance, replacement or repair of the emission control devices and systems may be performed by any motorcycle repair establishment or individual using parts that are "certified" to EPA standards.

An optional tool kit may be available. Check with your Honda dealer's parts department.

Before You Service Your Honda

The Importance of Maintenance	24
Maintenance Safety	25
Important Safety Precautions.....	25
Maintenance Schedule	26
General Competition Maintenance	29
Before & After Competition Maintenance.....	33
Between Motos & Practice Maintenance	33
After Competition Maintenance	33

Service Preparations

Maintenance Component Locations.....	35
Seat Removal	36
Fuel Tank Removal	37
Subframe Upright Position.....	39

Service Procedures

Fluids & Filters

Fuel System	41
Engine Oil	43
Transmission Oil	46
Coolant	48
Air Cleaner	51
Crankcase Breather	53

Engine

Throttle	54
Clutch System	56
Hot Start Lever.....	60
Spark Plug	61
Exhaust Pipe/Muffler	62
Spark Arrester.....	65
Valve Clearance.....	66
Piston/Piston Rings/Piston Pin.....	74

Chassis

Suspension.....	82
Front Suspension Inspection.....	82
Rear Suspension Inspection.....	83
Recommended Fork Oil	84
Fork Oil Change	84
Brakes.....	86
Wheels	90
Tires & Tubes	91
Side Stand.....	93
Drive Chain	94
Additional Maintenance Procedures	97

Electrical

Battery	99
Headlight & Taillight	101

Appearance Care	102
-----------------------	-----

The Importance of Maintenance

A well-maintained motorcycle is essential for safe, economical, and trouble-free riding. It will also help reduce air pollution. Careful pre-ride inspections and good maintenance are especially important because your CRF is designed to be ridden over rough off-road terrain.

To help you properly care for your CRF, this section of the manual provides a Maintenance Schedule. The service intervals in this schedule are based on average riding conditions.

More frequent service is needed if you subject your CRF to severe use or ride in unusually wet or dusty areas.

Frequent servicing of the air cleaner is especially important to help you avoid a possible costly engine repair.

If your CRF overturns or is involved in a crash, be sure your Honda dealer inspects all major parts, even if you are able to make some repairs.

Remember, proper maintenance is your responsibility. Be sure to inspect your CRF before each ride and follow the Maintenance Schedule in this section.

WARNING

Improperly maintaining this motorcycle or failing to correct a problem before you ride can cause a crash in which you can be seriously hurt or killed.

Always follow the inspection and maintenance recommendations and schedules in this owner's manual.

This section includes instructions on how to perform some important maintenance tasks. Some of the most important safety precautions follow. However, we cannot warn you of every conceivable hazard that can arise in performing maintenance. Only you can decide whether or not you should perform a given task.

WARNING

Failure to properly follow maintenance instructions and precautions can cause you to be seriously hurt or killed.

Always follow the procedures and precautions in this owner's manual.

Important Safety Precautions

- Make sure the engine is off before you begin any maintenance or repairs. This will help eliminate several potential hazards:

Carbon monoxide poisoning from engine exhaust. Be sure there is adequate ventilation whenever you operate the engine.

Burns from hot motorcycle parts. Let the engine and exhaust system cool before touching.

Injury from moving parts. Do not run the engine unless instructed to do so.

- Read the instructions before you begin, and make sure you have the tools and skills required.
- To help prevent the motorcycle from falling over, park it on a firm, level surface, using a side stand or an optional workstand to provide support.
- To reduce the possibility of a fire or explosion, be careful when working around gasoline. Use only a non-flammable (high flash point) solvent such as kerosene —not gasoline— to clean parts. Keep cigarettes, sparks, and flames away from all fuel-related parts.

Maintenance Schedule

To maintain the safety and reliability of your CRF, regular inspection and service is required as shown in the Maintenance Schedules – Regular OFF-ROAD Use (non-competition) and Competition Use – that follow.

The Maintenance Schedule list items that can be performed with basic mechanical skills and hand tools. Procedures for these items are provided in this manual.

The Maintenance Schedule also includes items that involve more extensive procedures and may require special training, tools, and equipment. Therefore, we recommend that you have your Honda dealer perform these tasks unless you have advanced mechanical skills and the required tools. Procedures for items in these schedules are provided in a service manual available for purchase from your Honda dealer (page 168).

Because your CRF does not have an odometer, service intervals in the maintenance schedules are expressed in terms of riding days as well as miles. To avoid overlooking required service, we urge you to develop a convenient way to record the number of days and/or distance traveled (USA: miles, Canada: kilometers) you ride.

If you do not feel capable of performing a given task or need assistance, remember that your Honda dealer knows your CRF best and is fully equipped to maintain and repair it. If you decide to do your own maintenance, use only genuine Honda parts or their equivalents for repair or replacement to ensure the best quality and reliability.

Perform the pre-ride inspection (page 11) at each scheduled maintenance period.

Each item on the maintenance schedule requires some mechanical knowledge. Certain items (particularly those marked *and**) may require more technical information and tools. Consult your Honda dealer.

- * Should be serviced by your Honda dealer, unless the owner has proper tools and service data and is mechanically qualified. Refer to the official Honda Service Manual (page 168).
- ** In the interest of safety, we recommend these items be serviced only by your Honda dealer.

Maintenance Procedures:

- I: inspect and clean, adjust, lubricate, or replace if necessary
- C: clean
- R: replace
- A: adjust
- L: lubricate

Maintenance Schedule

MAINTENANCE SCHEDULE – REGULAR OFF-ROAD USE (NON-COMPETITION)

ITEMS	FREQUENCY	Which ever Comes First ⇓	Initial Maintenance	Regular Maintenance Interval					Refer to Page:	
				mi	100	600	1,200	1,800		2,400
				km	150	1,000	2,000	3,000		4,000
	NOTE	Month	1	6	12	18	24			
* FUEL LINE					I			I	41	
** FUEL STRAINER SCREEN						C		C	42	
* THROTTLE OPERATION					I			I	55	
AIR CLEANER	(NOTE 1)			C	C	C	C	C	51	
CRANKCASE BREATHER				I	I	I	I	I	53	
SPARK PLUG				I	I	I	I	I	61	
* VALVE CLEARANCE			I	I	I	I	I	I	66	
ENGINE OIL			R	R	R	R	R	R	44	
ENGINE OIL FILTER			R	R	R	R	R	R	44	
* DECOMPRESSOR SYSTEM			I	I	I	I	I	I	–	
** ENGINE IDLE SPEED			I	I	I	I	I	I	134	
RADIATOR COOLANT	(NOTE 3)				I			R	48,50	
* COOLING SYSTEM			I	I	I	I	I	I	49	
* SECONDARY AIR SUPPLY SYSTEM	(NOTE 2)				I			I	–	
TRANSMISSION OIL			R	R	R	R	R	R	47	
DRIVE CHAIN	(NOTE 1)		I, L	I, L: every 300 mi (500 km) or 3 months					94,96	
DRIVE CHAIN SLIDER				I	I	I	I	I	96	
BRAKE FLUID	(NOTE 3)			I	I	I	I	I	87	
BRAKE PADS WEAR				I	I	I	I	I	89	
BRAKE SYSTEM			I	I	I	I	I	I	87	
* HEADLIGHT AIM					I			I	101	
CLUTCH SYSTEM			I	I	I	I	I	I	56	
SIDE STAND					I			I	93	
* SUSPENSION					I			I	82,83	
* SPARK ARRESTER				C: every 1,000 mi (1,600 km) or every 100 operating hours					65	
* NUTS, BOLTS, FASTENERS			I		I			I	98,154-156	
** WHEELS/TIRES			I	I	I	I	I	I	90,91	
** STEERING HEAD BEARINGS			I		I			I	97	

* Should be serviced by your Honda dealer, unless the owner has proper tools and service data and is mechanically qualified. Refer to the official Honda Service Manual (page 168).

** In the interest of safety, we recommended these items be serviced only by your Honda dealer.

Summary of Maintenance Schedule Notes and Procedures;

NOTES:

1. Service more frequently when ridden in wet or dusty conditions.
2. USA and Canada type only.
3. Replace every 2 years. Replacement requires mechanical skill.

Maintenance Schedule

MAINTENANCE SCHEDULE – COMPETITION USE

All items should be checked before each competition event. See your Honda dealer unless you are mechanically qualified and have the proper tools.

Damage from competition use is not covered by the Distributor’s Limited Warranty on your Honda.

Perform the Pre-ride Inspection (page 11) at each scheduled maintenance period.

I: Inspect and Clean, Adjust, Lubricate or Replace if necessary. C: Clean. L: Lubricate. R: Replace.

ITEMS		FREQUENCY	NOTE	About 2.5 hours	About 7.5 hours	About 15.0 hours	About 22.5 hours	About 30.0 hours	Ref. Page
THROTTLE OPERATION				I					55
HOT START SYSTEM				I					60
AIR FILTER			(NOTE 1)	C					51
CRANKCASE BREATHER				I					53
SPARK PLUG				I					61
RADIATOR COOLANT			(NOTE 2)	I					48
VALVE CLEARANCE/DECOMPRESSOR SYSTEM			(NOTE 4)			I			66
ENGINE OIL			(NOTE 3)	I		R			44
ENGINE OIL FILTER			(NOTE 3)			R			44
ENGINE IDLE SPEED				I					134
PISTON AND PISTON RINGS						R			76
PISTON PIN						R			76
TRANSMISSION OIL			(NOTE 5)	I		R			47
COOLING SYSTEM				I					49
DRIVE CHAIN				I,L	R				94-96
DRIVE CHAIN SLIDER				I					96
DRIVE CHAIN ROLLER				I					96
DRIVE SPROCKET				I					95
DRIVEN SPROCKET				I					95
BRAKE FLUID			(NOTE 2)	I					87
BRAKE PADS WEAR				I					89
BRAKE SYSTEM				I					86
CLUTCH SYSTEM			(NOTE 5)	I					56
CONTROL CABLES				I,L					97
EXHAUST PIPE/MUFFLER				I					62
SUSPENSION				I					82,83
SWINGARM/SHOCK LINKAGE					L				32
FORK OIL	FORK TUBE/SLIDER		(NOTE 3)		R				84
	DAMPER						R		111
NUTS, BOLTS, FASTENERS				I					98,154-156
WHEELS/TIRES				I					90,91
STEERING HEAD BEARINGS							I		97

This maintenance schedule is based upon average riding condition. Machine subjected to severe use require more frequent servicing.

- NOTE:
- 1.Clean after every heat for dusty riding conditions.
 - 2.Replace every 2 years. Replacement requires mechanical skill.
 - 3.Replace after the first break-in ride.
 - 4.Inspect after the first break-in ride.
 - 5.Replace the transmission oil, if the clutch discs and plates are replaced.

Perform maintenance on firm, level ground using the side stand, a workstand, or equivalent support.

When tightening bolts, nuts or screws, start with the larger diameter or inner fasteners, and tighten them to the specified torque using a crisscross pattern.

Use genuine Honda parts or their equivalent when servicing your CRF.

Clean parts in non-flammable (high flash point) cleaning solvent (such as kerosene) when disassembling. Lubricate any sliding surface, O-rings, and seals before reassembling. Grease parts by coating or filling where specified.

After any engine disassembly, always install new gaskets, O-rings, cotter pins, piston pin clips, snap rings, etc. when reassembling. After reassembly, check all parts for proper installation and operation.

All Pre-ride Inspection Items

Refer to *Pre-ride Inspection* page 11.

General Competition Maintenance

Spark Plug

Some non-resistor plugs may cause ignition problems. Refer to the recommendations elsewhere in this manual for specific types so you will be sure to use the proper reach and heat range. Replace periodically as specified in the Maintenance Schedule (pages 27, 28).

Engine oil and Filter

Drain and replace engine oil often to ensure the greatest service life of the piston, cylinder and crankshaft. Also replace engine oil filter often to ensure the greatest service life. Frequent changes will also assure consistent performance of power and response. (page 44).

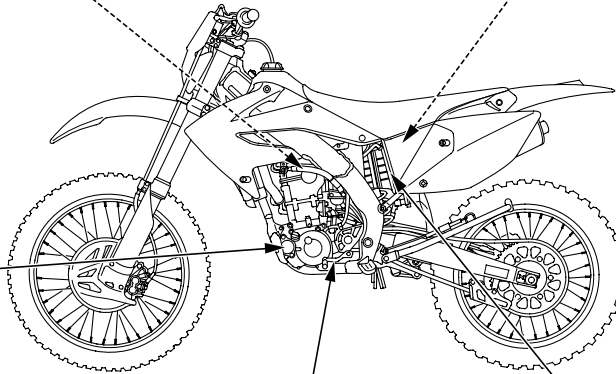

Transmission Oil

Drain and replace transmission oil often to ensure the greatest service life of the transmission and clutch. Frequent changes will also assure consistent performance of both shifting and clutch action (page 47).

Air Cleaner

Clean and oil your air cleaner regularly because the volume of air able to pass through it has a great effect on performance. Both engine performance and long term durability may be affected by an air cleaner that has deteriorated and allows dirt to pass. Inspect the air cleaner closely each time it's serviced for evidence of small tears or seam separation. Keep a spare air cleaner oiled and ready to install, sealed in a plastic bag. Riding in dusty conditions may require servicing the air cleaner or replacing it with a pre-serviced air cleaner between motos. Be careful not to over oil the air cleaner. While it is important to oil the air cleaner thoroughly, over oiling will cause an overall rich running condition, probably more noticeable off idle and in low rpm performance. Follow the servicing instructions in the Maintenance section. Use Pro Honda Foam Filter Oil or an equivalent. Be sure to grease the air cleaner flange where it contacts the air cleaner housing. Pro Honda White Lithium Grease, or an equivalent, is handy for this because any dirt that penetrates this sealing area will show up clearly (page 51).

Use the Honda genuine air cleaner or an equivalent air cleaner specified for your model.

Using the wrong Honda air cleaner or a non-Honda air cleaner which is not of equivalent quality may cause premature engine wear or performance problems.

Air Cleaner Housing Sealing

Remove and reseal the air cleaner housing boot where it connects to the air cleaner housing with Pro Honda Handgrip Cement or equivalent if there is any doubt to its sealing integrity. Inspect the air cleaner and air intake tract regularly for signs of deterioration or dirt penetration.

Handgrips

Always use Pro Honda Handgrip Cement (U.S.A only) or equivalent when replacing handgrips.

Throttle grip

Align the index mark on the throttle grip with the edge of the throttle cable guide. Left handlebar grip: Align the "Δ" mark on the left handlebar grip with the paint mark on the handlebar.

Refer to the Honda Service Manual (page 168) for installation instructions.

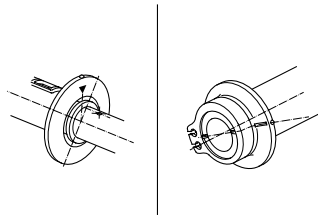

For added security, you may choose to bind the handgrips to the handlebar and throttle pipe with safety wires to prevent the possibility of them loosening. Position the twisted wire ends away from your palms and be sure to bend the wire ends well into the handgrip rubber so they will not snag your glove.

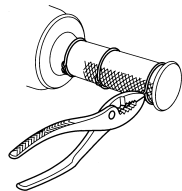

Throttle Control

Remove the throttle control every few rides, clean the inside of the throttle pipe and handlebar thoroughly, and apply a light coating of oil. Inspect the cable carefully for kinks or other damage that may restrict throttle control in any way. Move the handlebar from lock to lock to be sure there is no cable interference. Make certain the throttle operation is perfect after servicing and inspecting.

Fuel Filter

Periodically drain the fuel from the fuel tank, remove and clean the fuel valve/filter. Replace the fuel valve O-ring if there are any signs of damage or deterioration (page 42).

Cylinder Removal

Put a little grease on the cylinder mounting dowels to prevent corrosion from dissimilar metals. The tolerances are quite tight, so it's important to keep these dowels absolutely clean (page 76).

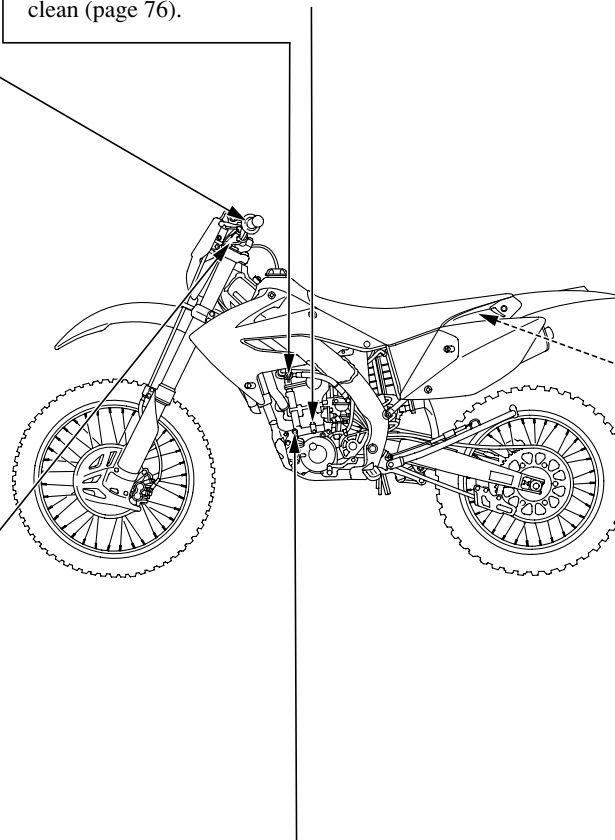

Engine Mounting Bolts and Nuts

Make sure the engine mounting bolts and nuts are tightened to the proper torque specification. For added peace of mind, remove the nuts, clean the threads, and apply Pro Honda Hondalock or an equivalent prior to torquing the nuts.

Fuel Contamination

Refer to *Fuel System* in your Owner's Manual (page 41). Check the fuel lines for deterioration, damage, or leakage. Replace the fuel lines, if necessary.

Periodically drain the fuel from the fuel tank, remove and clean the fuel valve and fuel filter. Replace the fuel valve O-ring if there are any signs of damage or deterioration (page 42).

Loosen the carburetor drain screw and examine the fuel that flows out of the float bowl. If you notice anything in the fuel, such as water or dirt, remove the float bowl and inspect its contents (page 131).

For maximum efficiency, drain and replace fuel that has remained in your fuel tank for more than a month.

Gaskets

Always use new gaskets when reassembling components.

Battery

Electrical accessories use current from the battery – even when the engine is off.

Limited operation also allows the battery to discharge. If you have electrical accessories on your CRF – or do not ride frequently, we recommend that you charge the battery frequently (see *Battery Charging*, page 100).

If you do not expect to ride your CRF for at least two weeks, we recommend you remove the battery – or at least disconnect the battery cables (negative cable first).

Electrical Connectors

Clean electrical connectors and wrap them with electrical tape to reduce the possibility of unwanted disconnections, water shorts or corrosion. Additional corrosion protection is offered by using Pro Honda Dielectric Grease on all electrical connections.

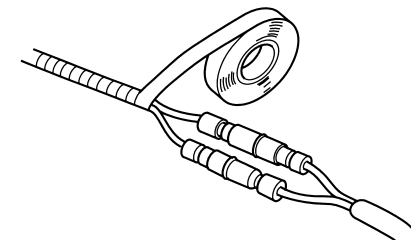

General Competition Maintenance

Suspension Linkage Lubrication

Disassemble, clean, inspect and lubricate all suspension linkage pivots with grease after each 7.5 hours of running time in order to maintain proper suspension performance and minimize component wear.

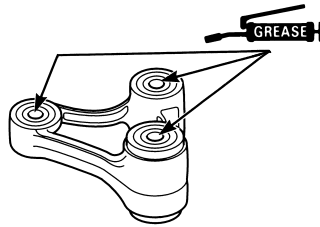

Swingarm Pivot Lubrication

Clean, inspect and lubricate the swingarm and suspension linkage pivots with grease. Be sure all of the dust seals are in good condition.

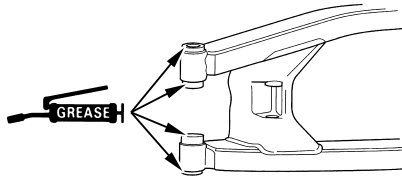

Swingarm

Do not attempt to weld or otherwise repair a damaged swingarm. Welding will weaken the swingarm.

Footpegs

Worn footpeg teeth can be repaired by filing the grooves between the teeth with a triangular shaped file.

Be aware that filing them too sharp will reduce boot sole lifespan. Sharpen only the points of the teeth. Filing the grooves deeper will weaken the footpegs. Be sure the pegs are free to pivot freely and that the pivot pin retaining cotter pins are in good condition.

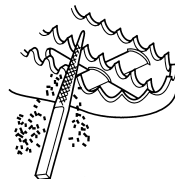

Fuse

Check the fuse before looking elsewhere for the cause of an electrical problem.

Brake Fluid Replacement

Refer to *Brake Pad Wear* in your Owner's Manual, page 89. **Brake Caliper Inspection:** Be sure both the front and rear calipers are able to move freely on the caliper bracket pins. Check pad thickness periodically and replace the pads when minimum thickness is reached. If the brakes fade when they are hot, inspect the pads for glazing or damage, and replace if necessary.

Brake Fluid Replacement: Replace the hydraulic fluid in the brake system every 2 years. Replace the fluid more frequently if you subject your brakes to severe use. Heavy braking heats the brake fluid and it may deteriorate sooner than expected. Any type of riding, that requires frequent use of the brakes, such as in tight woods, can shorten the service life of brake fluid.

Water Leakage Check Hole

After every race, check the leakage check hole, located just below the water pump cover on the right crankcase cover. Clean away any clogged dirt or sand, if necessary. Look for coolant or oil leakage. Leaking coolant indicates a worn or damaged water seal. Leaking oil indicates a bad transmission oil seal. If replacement is necessary, both seals should be replaced.

Steering Head Bearings

Periodically clean, inspect and regrease the steering head bearings — especially if wet, muddy or extremely dusty courses are encountered often.

Use urea based multi-purpose grease designed for high temperature, high pressure performance (example: EXCELITE EP2 manufactured by KYODO YUSHI, Japan or Shell Stamina EP2 or equivalent).

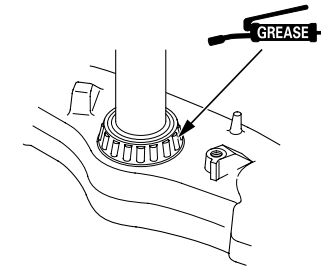

Fork Oil/Performance

Disassemble, clean and inspect the fork and replace the oil regularly. Contamination due to the tiny metal particles produced from the normal action of the fork, as well as normal oil breakdown, will deteriorate the performance of the suspension. Refer to the Honda Service Manual (page 168). Use only Pro Honda HP Fork Oil 5W (U.S.A. only) or equivalent which contains special additives to assure maximum performance of your CRF's front suspension.

Frame

Because your CRF is a high-performance machine, the frame should not be overlooked as part of your overall competition maintenance program. Periodically inspect the frame closely for possible cracking or other damage. It makes good racing sense.

Spokes

Check spoke tension frequently between the first few rides. As the spokes, spoke nuts and rim contact points seat-in, the spokes may need to be retightened. Once past this initial seating-in period, the spokes should hold their tension. Still, be sure your race maintenance program includes checking spoke tension and overall wheel condition on a regular basis (page 90).

Nuts, Bolts, Etc

Application of a thread locking agent to essential fasteners offers added assurance and security. Remove the nuts, clean the threads of both the nuts and bolts, apply Pro Honda Hondalock or an equivalent and tighten to the specified torque.

Before & After Competition Maintenance

Between Motos & Practice Maintenance

After practice or between motos you have a chance to make additional checks and adjustments.

- Clean accumulated dirt from under the fenders and off the wheels, suspension components, handgrips, controls, and footpegs. A stiff, nylon parts cleaning brush works well.
- Check tire air pressure.
- Check spoke tension and rim lock security.

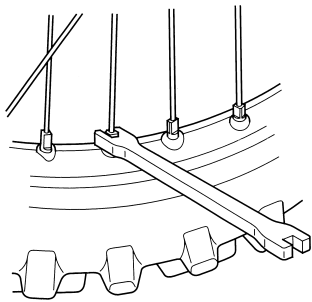

- Check sprocket bolt and nut security.
- Clean the sides of the drive chain with a stiff, nylon parts-cleaning brush. Lubricate and adjust the chain as necessary.

Do not perform maintenance while engine is running. Injury to your fingers or hands may result.

- After adjustment, check that the chain adjuster index marks (1) are in the same position on each side. This will ensure that the rear wheel is in proper alignment and allow maximum performance from the rear disc brake. Maintaining proper wheel alignment will also extend brake pad wear.

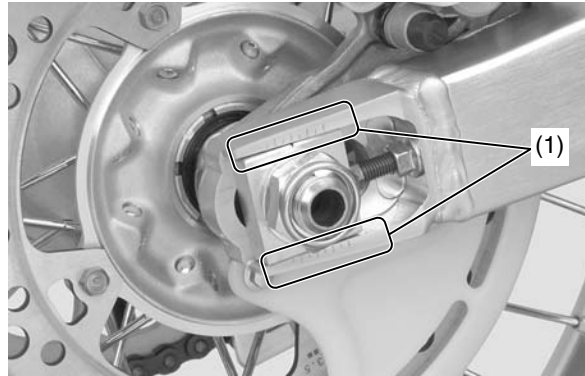

(1) chain adjuster index marks

- Suspend the front wheel above the ground and use the pressure release screws (2) to release the built-up pressure (in excess of normal atmospheric pressure: 0 psi (0 kPa, 0 kgf/cm²)) in the fork tubes. This pressure is caused by normal fork action while riding. (If you are riding at altitude, remember that fork pressure of 0 at sea level will increase as elevation increases.)

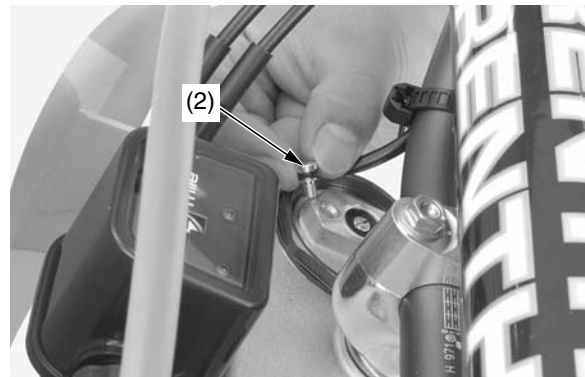

(2) pressure release screw

After Competition Maintenance

It is important to the long term performance of your CRF to practice a consistent maintenance program. Right after the event is a good time to begin your next maintenance cycle.

After Race Lubrication

Apply a light coating of rust-inhibiting oil to the drive sprocket and any steel portions of the chassis or engine where the paint has worn away. This will prevent rusting of the exposed metal. Apply rust-inhibiting oil more heavily if the event was particularly wet or muddy. Take care to avoid spraying any oil near the brake pads or the brake discs.

Clean and lubricate the drive chain (page 96). Be sure the chain is wiped clean and is dry before lubricating the chain.

Take care to prevent catching your fingers between the chain and sprocket.

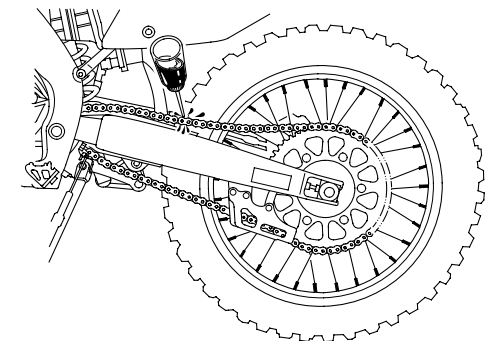

Before & After Competition Maintenance

Routine Cleaning

If your CRF is only slightly dirty, it is best to clean it by hand with the aid of a stiff bristled nylon brush and some clean rags.

Take care to prevent catching your fingers between the chain and sprocket.

A variety of reasonably priced cleaning brushes are available from variety, drug, food, and hardware stores. Some of these brushes are extremely useful in removing dirt from the many tight contours of the metal pieces of your CRF. Avoid using stiff, abrasive brushes on the plastic or rubber parts.

If your CRF was exposed to sea air or salt water, rinse it as soon as possible after the event, dry it, and apply a spray lubricant to all metal parts.

If you decide to wash your CRF or use cleaners, refer to *Appearance Care* (page 102).

Maintenance Component Locations

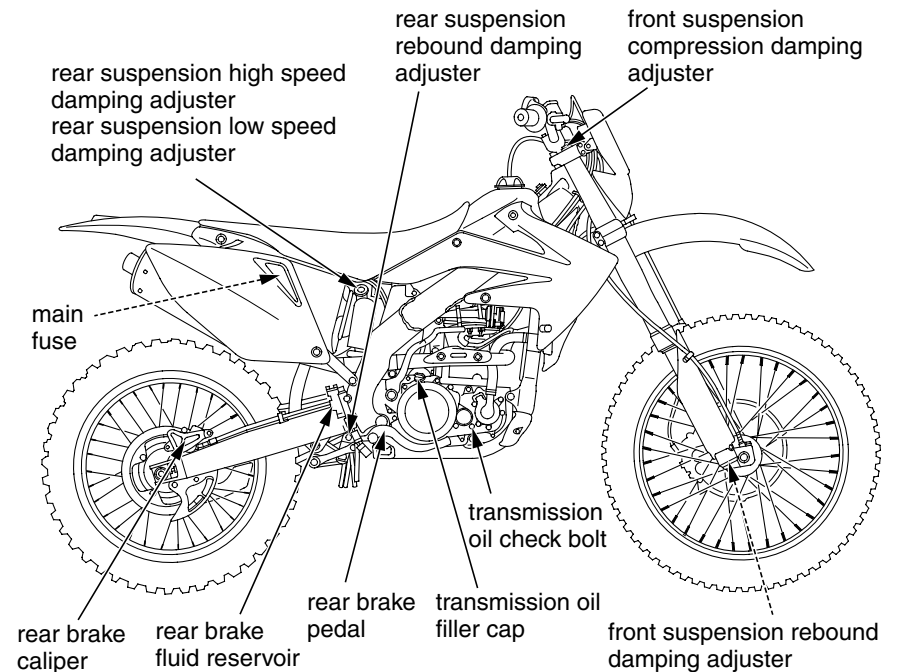
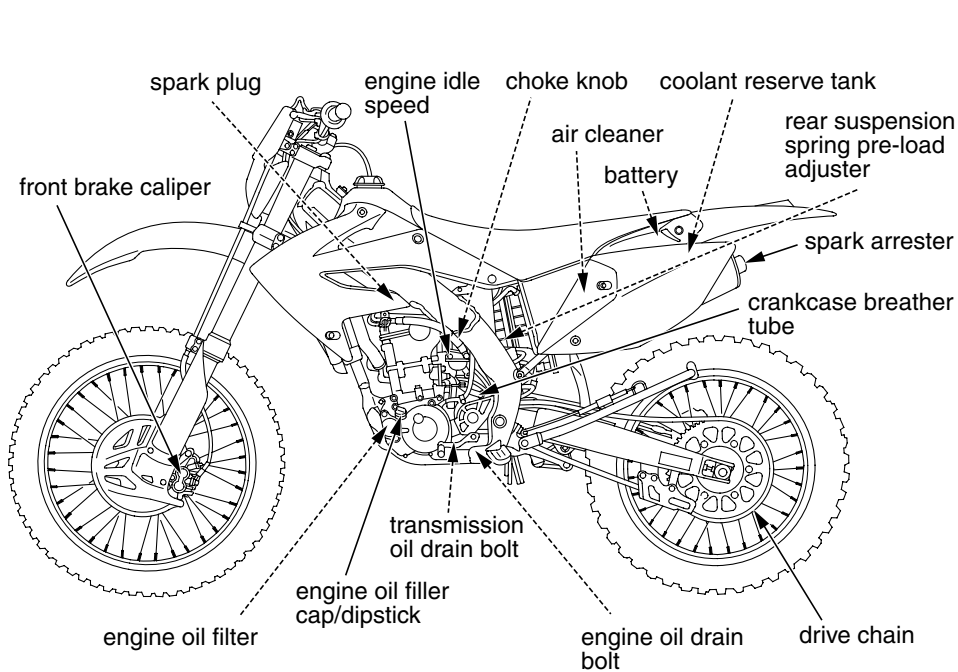
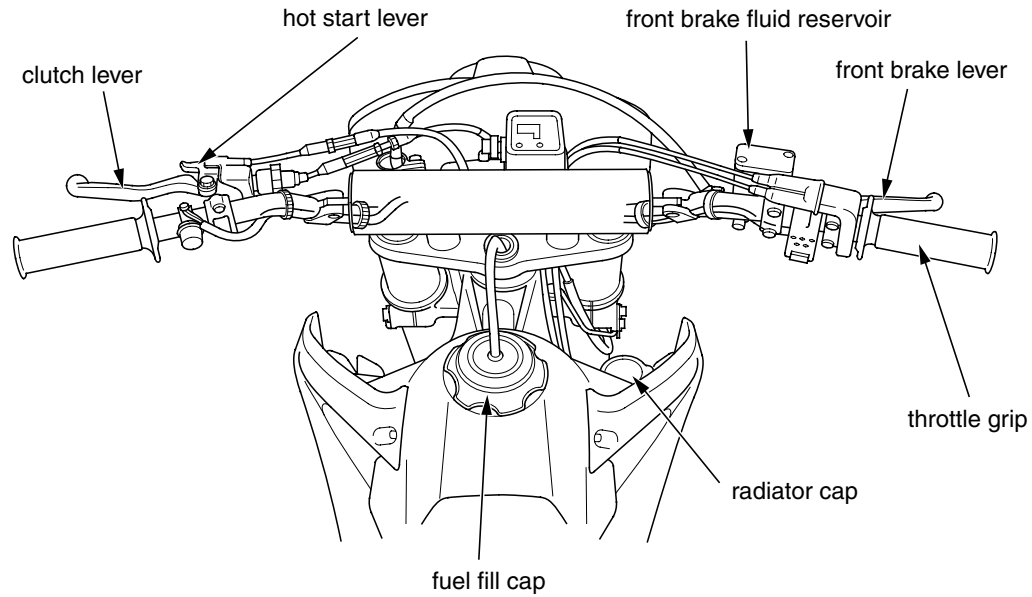

Seat Removal

Refer to *Safety Precautions* on page 25.

Removal

1. Remove the seat mounting bolts (1).
2. Remove the seat (2) by sliding it backward.

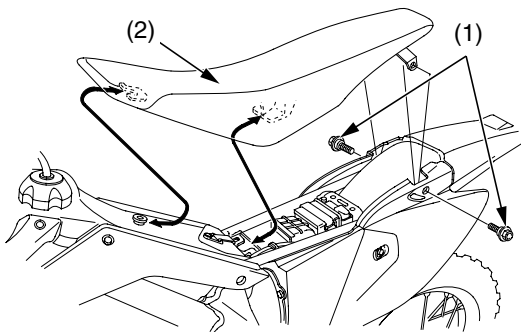

(1) seat mounting bolts (2) seat

Installation

1. Install the seat while aligning the seat front prong (3) with the seat bracket (4) and seat rear prong (5) with the tab (6) of the frame.
2. Install and tighten the seat mounting bolts to the specified torque:
19 lbf·ft (26 N·m, 2.7 kgf·m)

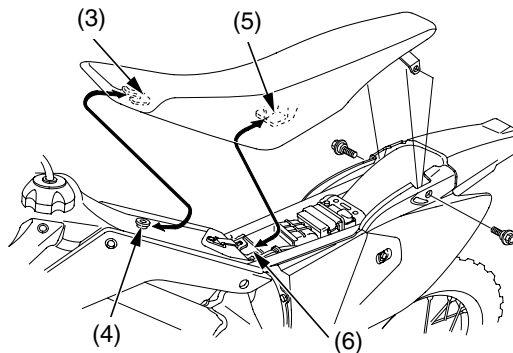

(3) seat front prong
(4) seat bracket
(5) seat rear prong
(6) tab

Fuel Tank Removal

Refer to *Safety Precautions* on page 25.

Removal

1. Turn the fuel valve OFF.
2. Remove the seat (page 36).
3. Remove the shroud A bolts/collars (1).
4. Remove the shroud B bolts/collars (2) and shrouds (3).

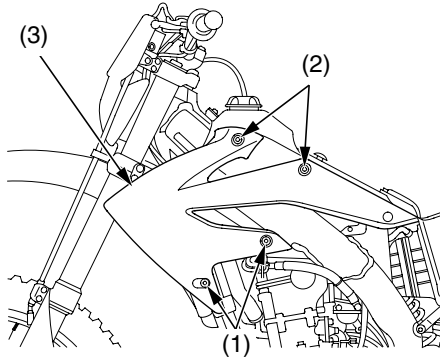

- (1) shroud A bolts/collars
(2) shroud B bolts/collars
(3) shroud

5. Pull the breather tube (4) out of steering stem nut.
6. Unhook and remove the fuel tank band (5).
7. Unhook the air cleaner cover rubber (6).
8. Remove the fuel tank bolt (7).

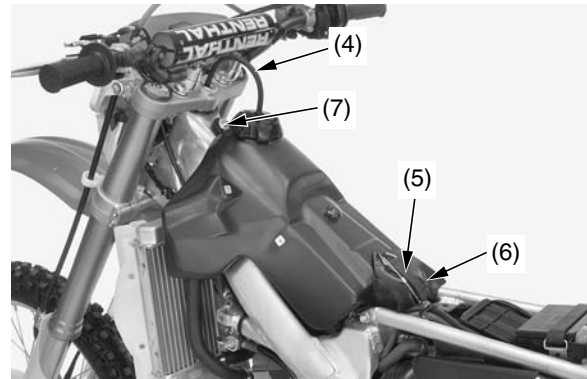

- (4) breather tube
(5) fuel tank band
(6) air cleaner cover rubber
(7) fuel tank bolt

9. Disconnect the fuel line (8) from the fuel valve (9). The fuel line leading to the carburetor must be disconnected, not the fuel line leading to the fuel tank.
10. Remove the fuel valve bolt (10) and fuel valve.
11. Remove the fuel tank.

⚠ WARNING

Gasoline is highly flammable and explosive. You can be burned or seriously injured when handling fuel.

- Stop the engine and keep heat, sparks and flame away.
- Handle fuel only outdoors.
- Wipe up spills immediately.

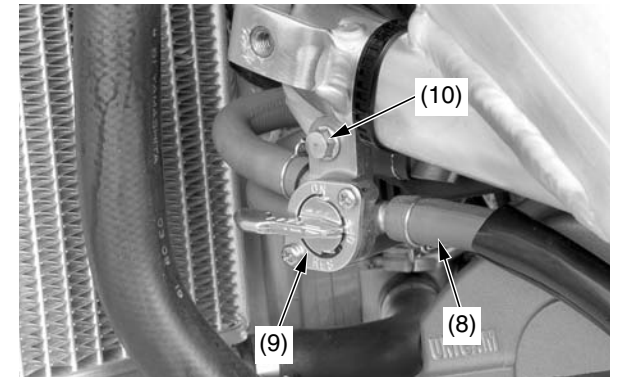

- (8) fuel line
(9) fuel valve

- (10) fuel valve bolt

Fuel Tank Removal

Installation

1. Install the fuel tank on the frame.
2. Install the fuel valve (1) and tighten fuel valve bolt (2).
3. Connect the fuel line (3) to the fuel valve.

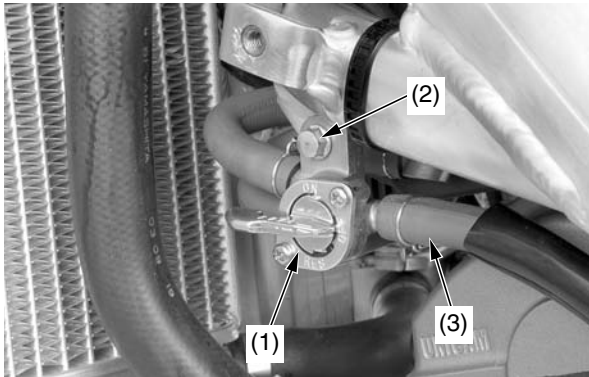

(1) fuel valve
(2) fuel valve bolt
(3) fuel line

4. Install and tighten the fuel tank bolt (4).
5. Hook the air cleaner cover rubber (5).
6. Install the fuel tank band (6).
7. Put the breather tube (7) in the steering stem nut.

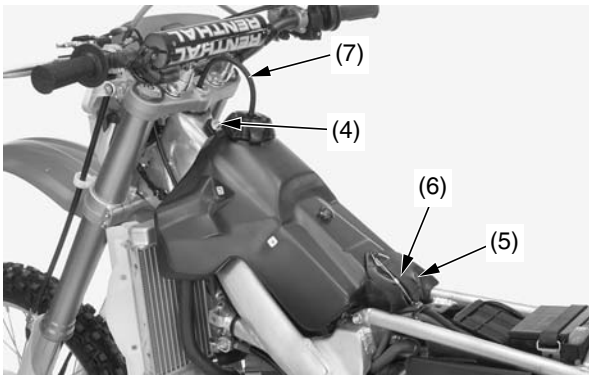

(4) fuel tank bolt
(5) air cleaner cover rubber
(6) fuel tank band
(7) breather tube

8. Install the shrouds (8) and shroud B bolts/collars (9).
Tighten the shroud B bolts to the specified torque:
3.7 lbf-ft (5 N·m, 0.5 kgf·m)
9. Install the shroud A bolts/collars (10).

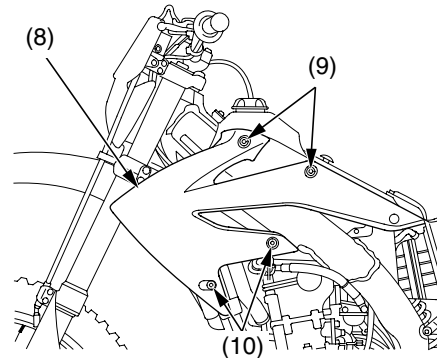

- (8) shroud
(9) shroud B bolts/collars
(10) shroud A bolts/collars
10. Install the seat (page 36).

Subframe Upright Position

Refer to *Safety Precautions* on page 25.

The subframe may be adjusted to an upright position to permit servicing of the rear suspension.

Upright Position

1. Remove the right side cover bolt (1), collar (3), seat mounting bolt (2) and right side cover (4).

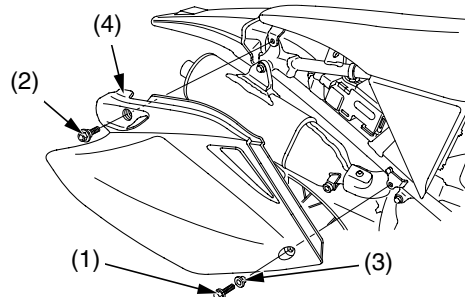

- (1) right side cover bolt (3) collar
(2) seat mounting bolt (4) right side cover

2. Open the air cleaner housing cover (5) by turning the quick fastener (6) counterclockwise and remove the left side cover bolt (7), collar (9), seat mounting bolt (8) and left side cover (10).

3. Remove the seat (11) (page 36).

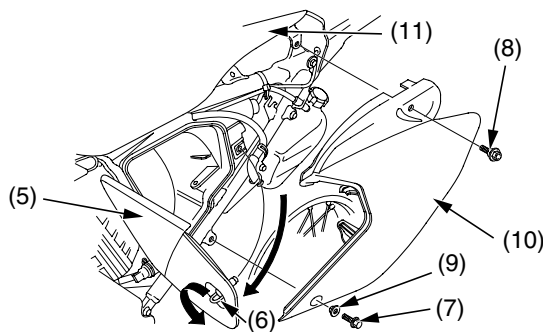

- (5) air cleaner housing cover (9) collar
(6) quick fastener (10) left side cover
(7) left side cover bolt (11) seat
(8) seat mounting bolt

4. Remove the muffler (page 62).
5. Remove the wire band (12), rear suspension upper mounting nut (13) and bolt (14).

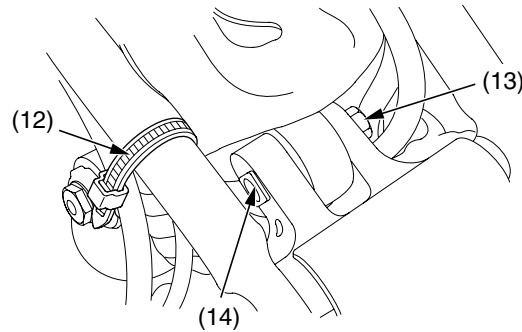

- (12) wire band
(13) rear suspension upper mounting nut
(14) rear suspension upper mounting bolt

6. Loosen the screw (15) on the air cleaner connecting tube clamp (16).

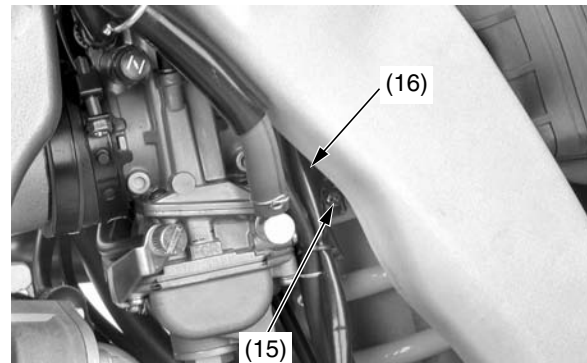

- (15) screw
(16) air cleaner connecting tube clamp

7. Loosen the subframe mounting upper bolt (17) and remove the subframe mounting lower bolts (18).

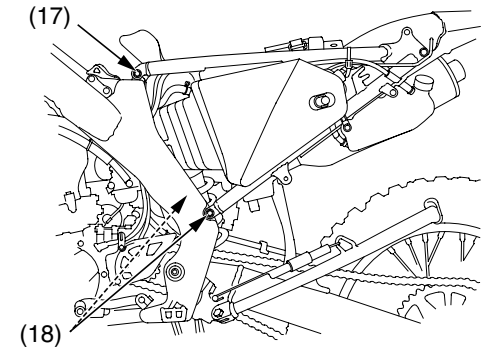

- (17) subframe mounting upper bolt
(18) subframe mounting lower bolts

8. Lift the subframe (19) as shown. Tighten the subframe mounting upper bolt to the specified torque:
22 lbf-ft (30 N·m, 3.1 kgf·m)

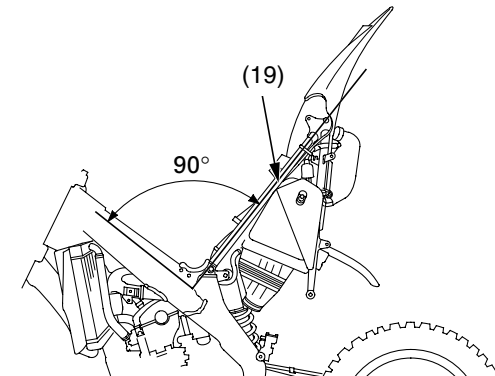

- (19) subframe

Subframe Upright Position

Installation

1. Loosen the subframe mounting upper bolt (1).
2. Loosely attach the lower ends of the subframe (2) to the mainframe while connecting the air cleaner connecting tube to the carburetor. Then align the subframe with the rear wheel and tighten the subframe mounting lower bolts (3) and subframe mounting upper bolt to the specified torque:
upper bolts: 22 lbf-ft (30 N·m, 3.1 kgf·m)
lower bolt: 36 lbf-ft (49 N·m, 5.0 kgf·m)

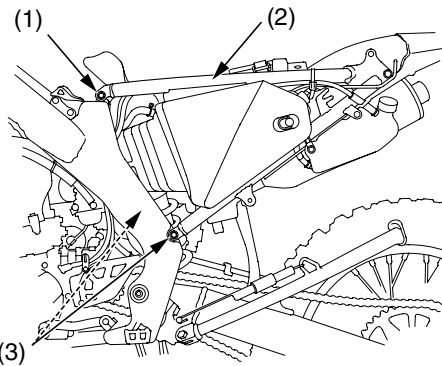

- (1) subframe mounting upper bolt
- (2) subframe
- (3) subframe mounting lower bolts

3. Tighten the screw (4) on the air cleaner connecting tube clamp (5).

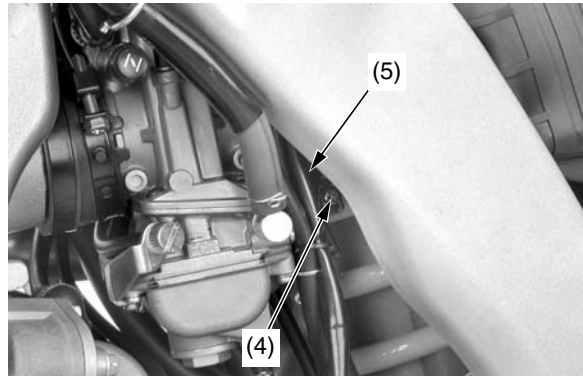

- (4) screw
- (5) air cleaner connecting tube clamp

4. Install the rear suspension upper mounting bolt (6), nut (7) and wire band (8). Tighten the rear suspension upper mounting nut to the specified torque:
32 lbf-ft (44 N·m, 4.5 kgf·m)

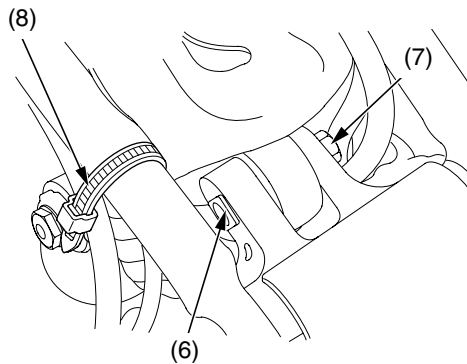

- (6) rear suspension upper mounting bolt
- (7) rear suspension upper mounting nut
- (8) wire band

5. Install the muffler (page 63).

6. Install the seat (9) (page 36).
7. Install the left side cover (10), seat mounting bolt (11), collar (12) and left side cover bolt (13). Close the air cleaner housing cover (14) and turn the quick fastener (15) clockwise.

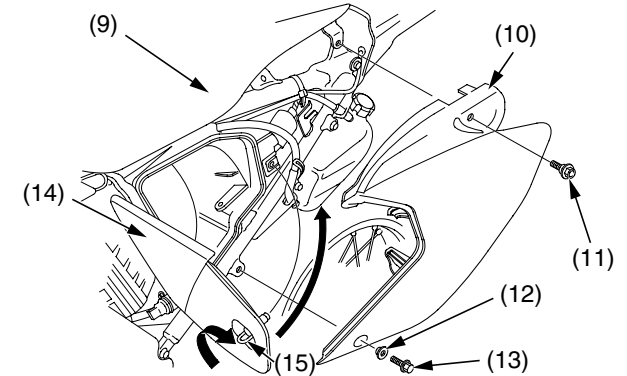

- (9) seat
- (10) left side cover
- (11) seat mounting bolt
- (12) collar
- (13) left side cover bolt
- (14) air cleaner housing cover
- (15) quick fastener

8. Install the right side cover (16), seat mounting bolt (17), collar (18) and right side cover bolt (19).

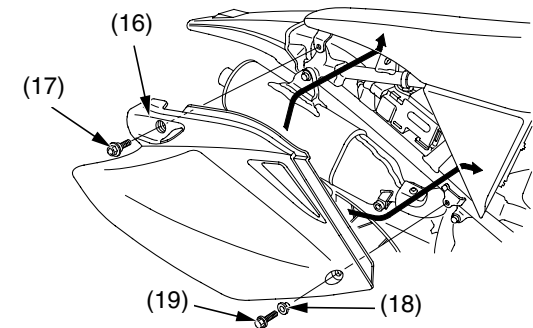

- (16) right side cover
- (17) seat mounting bolt
- (18) collar
- (19) right side cover bolt

9. Tighten the seat mounting bolts to the specified torque:
19 lbf-ft (26 N·m, 2.7 kgf·m)

Refer to *Safety Precautions* on page 25.

Fuel Recommendation

Type	Unleaded
Pump Octane Number	91 (or higher)

We recommend that you use unleaded fuel because it produces fewer engine deposits and extends the life of exhaust system components.

Your engine is designed to use any gasoline that has a pump octane number of 91 or higher. Gasoline pumps at service stations normally display the pump octane number. For information on the use of oxygenated fuels, see page 160.

Use of lower octane gasoline can cause persistent “pinging” or “spark knock” (a louder rapping noise) which, if severe, can lead to engine damage. (Light pinging experienced while operating under a heavy load, such as climbing a hill, is no cause for concern.)

If pinging or spark knock occurs at a steady engine speed under normal load, change brands of gasoline. If pinging or spark knock persists, consult your Honda dealer.

Never use stale or contaminated gasoline. Avoid getting dirt, dust or water in the fuel tank.

Refueling Procedure

Fuel Tank Capacity: 2.19 US gal (8.3 ℓ)

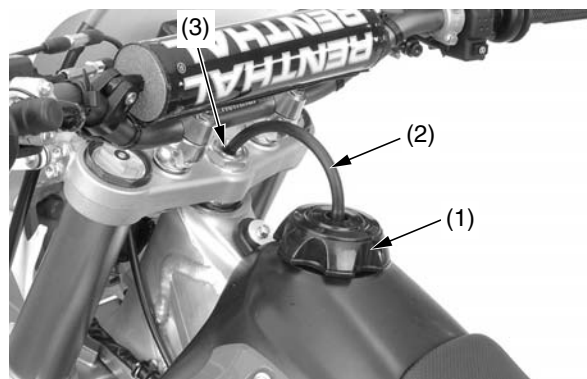

- (1) fuel fill cap (3) steering stem nut
(2) breather tube

1. To open the fuel fill cap (1), pull the breather tube (2) out of the steering stem nut (3). Turn the fuel fill cap counterclockwise and remove it.
2. Add fuel until the level reaches the bottom of the filler neck. Avoid overfilling the tank. There should be no fuel in the filler neck.
3. Close the fuel fill cap and insert the breather tube in the steering stem nut.

⚠ WARNING

Gasoline is highly flammable and explosive. You can be burned or seriously injured when handling fuel.

- Stop the engine and keep heat, sparks and flame away.
- Handle fuel only outdoors.
- Wipe up spills immediately.

Fuel Line

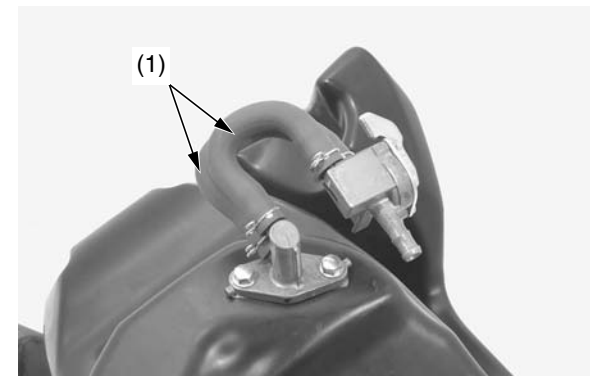
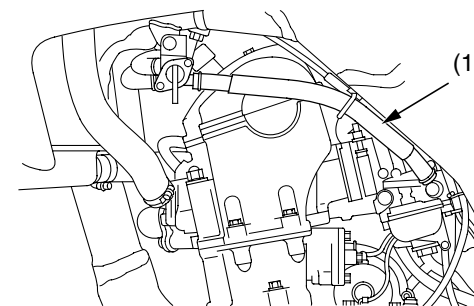

(1) fuel line

1. Check for leaks.
2. Check the fuel line (1) for cracks, deterioration, damage or leakage. Replace the fuel line, if necessary.
3. Check for interference between the frame and tank and adjust if necessary.

Fuel System

Fuel Filter

The fuel filter is mounted on the bottom left side of the fuel tank. Dirt accumulated in the filter will restrict the flow of the fuel to the carburetor.

To service the fuel filter:

1. Drain the fuel from the fuel tank into an approved gasoline container.
2. Remove the fuel tank (page 37).
3. Remove the fuel joint (1) from fuel tank by removing the bolts (2).

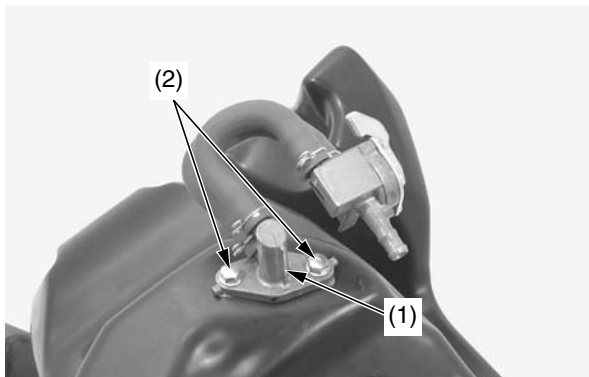

(1) fuel joint

(2) bolts

4. Wash the fuel filter (3) in high flash-point cleaning solvent.
5. Check that the O-ring (4) is in good condition and install it onto the fuel joint. Install the fuel filter in the fuel tank by tightening the bolts to the specified torque:
7 lbf·ft (10 N·m, 1.0 kgf·m)

Refill the fuel tank.

Attach the fuel valve and fuel line, and turn the fuel valve to ON or RES; check for fuel leaks.

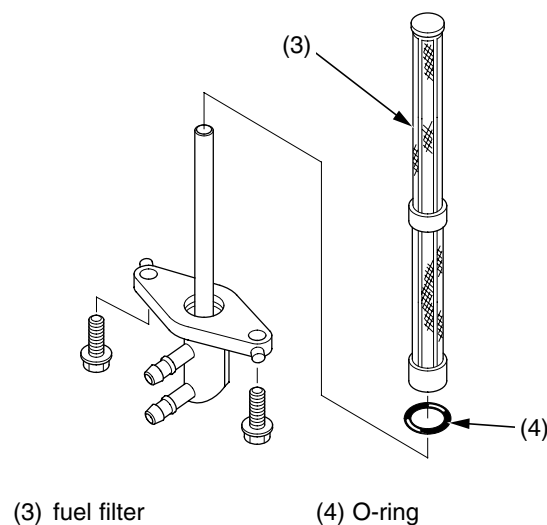

(3) fuel filter

(4) O-ring

Refer to *Safety Precautions* on page 25.

Using the proper oil, and regularly checking, adding, and changing oil will help extend the service life of the engine. Even the best oil wears out. Changing oil helps get rid of dirt and deposits. Operating the engine with old or dirty oil can damage your engine. Running the engine with insufficient oil can cause serious damage to the engine.

Oil Recommendation

API classification	SG or higher except oils labeled as energy conserving on the circular API service label
viscosity (weight)	SAE 10W-30
JASO T 903 standard	MA
suggested oil*	Pro Honda GN4 4-stroke oil or an equivalent*

* Suggested 4-stroke engine oils are equal performance to SJ oils that are not labeled as energy conserving on the circular API service label.

- Your CRF does not need oil additives. Use the recommended oil.
- Do not use API SH or higher 4-stroke engine oils displaying a circular API “energy conserving” service label on the container. They may affect lubrication.

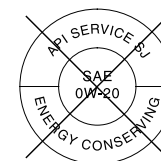

NOT RECOMMENDED

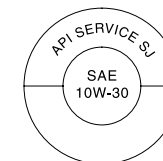

OK

- Oil is a major factor affecting the performance and service life of the engine.

Other viscosities shown in the following chart may be used when the average temperature in your riding area is within the indicated range.

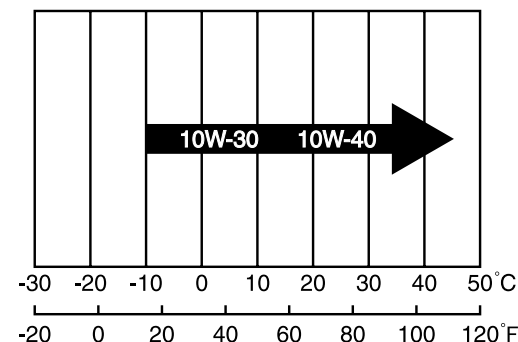

Engine Oil

JASO T 903 standard

The JASO T 903 standard is an index for engine oils for 4-stroke motorcycle engines.

There are two classes: MA and MB.

Oil conforming to the standard is labeled on the oil container.

For example, the following label shows the MA classification.

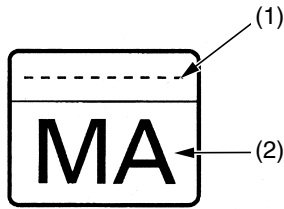

PRODUCT MEETING JASO T 903
COMPANY GUARANTEEING THIS MA PERFORMANCE:

- (1) code number of the sales company of the oil
(2) oil classification

Checking & Adding Oil

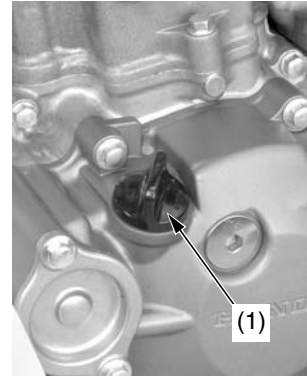
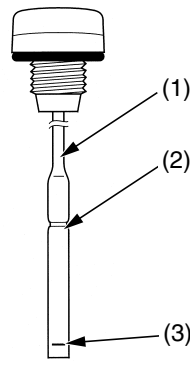

- (1) engine oil filler cap/dipstick
(2) upper level mark
(3) lower level mark

1. Run the engine at idle for 3 minutes, then shut it off.
2. Wait 3 minutes after shutting off the engine to allow the oil to properly distribute itself in the engine.
3. Support the CRF in an upright position on a level surface.
4. Remove the engine oil filler cap/dipstick (1), wipe it clean, and insert the engine oil filler cap/dipstick without screwing it in. Remove the engine oil filler cap/dipstick.
5. Check that the oil level is between the upper (2) and lower (3) level marks on the engine oil filler cap/dipstick.
 - If the oil is at or near the upper level mark, you do not have to add oil.
 - If the oil is below or near the lower level mark and add the recommended oil until the upper level mark. (Do not overfill)
Reinstall the engine oil filler cap/dipstick. Repeat steps 1–5.
6. Reinsert the engine oil filler cap/dipstick.
7. Check for oil leaks.

Changing Engine Oil & Filter

1. Run the engine at idle for 3 minutes, then shut it off.
2. Support the CRF in an upright position on a level surface.
3. Remove the engine oil filler cap/dipstick (1) from the left crankcase cover.
4. Place an oil drain pan under the engine to catch the oil. Then remove the engine oil drain bolt (2) and sealing washer (3).
5. With the engine stop button pushed, repeat kickstarter operation approximately 5 times to drain the engine oil completely.
6. After the oil has drained, apply fresh engine oil to the engine oil drain bolt threads and tighten it with a new sealing washer to the specified torque:
12 lbf-ft (16 N·m, 1.6 kgf·m)

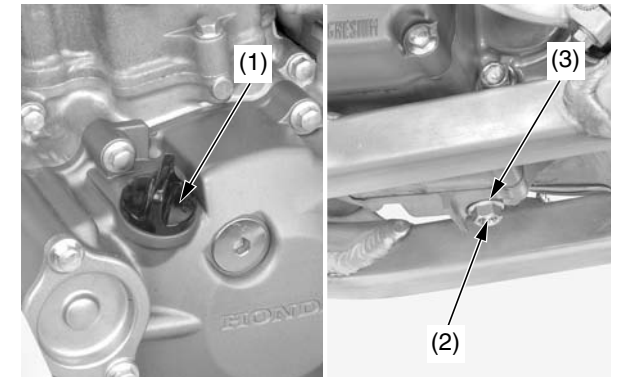

- (1) engine oil filler cap/dipstick
(2) engine oil drain bolt
(3) sealing washer

7. It is recommended to replace the oil and filter about every 15.0 hours. However, if you replace only the oil before the recommended interval, see page 28.

- Remove the left engine guard bolt (4) and left engine guard (5).

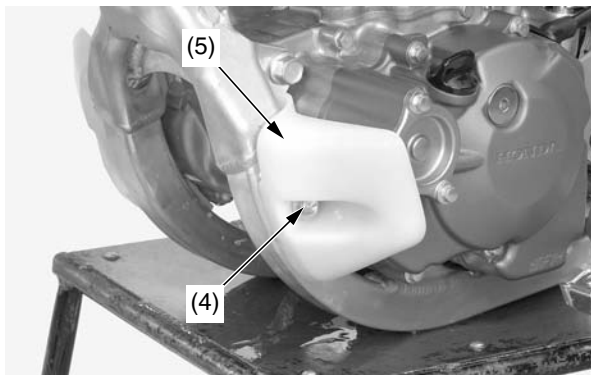

- (4) left engine guard bolt
(5) left engine guard

- Remove the oil filter cover bolts (6) and oil filter cover (7).
- Remove the oil filter (8) from the oil filter cover.
- Check that the oil filter cover O-ring (9) is in good condition. Replace it if necessary.

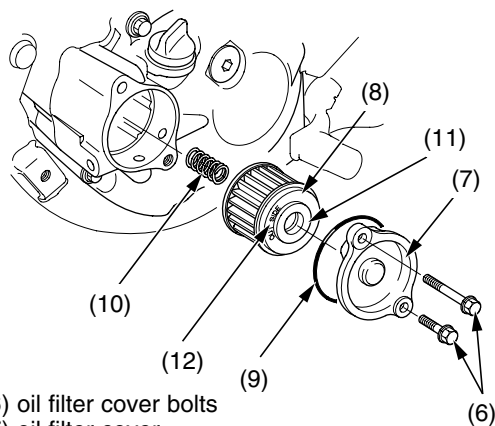

- (6) oil filter cover bolts
(7) oil filter cover
(8) oil filter
(9) oil filter cover O-ring
(10) spring
(11) rubber seal
(12) "OUT-SIDE" mark

- Apply grease to the filter side of the spring end, then install the spring (10) into the new oil filter.
- Position the spring against the engine crankcase and install a new oil filter with the rubber seal (11) facing out, away from the engine. You should see the "OUT-SIDE" mark (12) on the filter body, near the rubber seal. Use a new genuine Honda oil filter or a filter of equal quality specified for your model.

NOTICE

If the oil filter is not installed properly, it will cause serious engine damage.

- Apply engine oil to a new O-ring and install it to the oil filter cover.
- Install the oil filter cover being careful not to damage the O-ring, then tighten the oil filter cover bolts to the specified torque:
9 lbf-ft (12 N·m, 1.2 kgf·m)
- Install the left engine guard and bolt, then tighten them.
- Fill the crankcase with the recommended oil.
Capacity: 0.73 US qt (0.69 ℓ)
at oil and filter change
0.70 US qt (0.66 ℓ)
at oil change
- Install the engine oil filler cap/dipstick.
- Check the engine oil level by following the steps in *Checking & Adding Oil* (page 44).

Transmission Oil

Refer to *Safety Precautions* on page 25.

Using the proper oil, and regularly checking, adding, and changing oil will help extend the service life of the transmission and clutch. Even the best oil wears out. Changing oil helps get rid of dirt and deposits. Operating the engine with old or dirty oil can damage your engine. Running the engine with insufficient oil can cause serious damage to the engine and transmission.

Oil Recommendation

API classification (4-stroke engine oil only)	SG or higher except oils labeled as energy conserving on the circular API service label
Viscosity (weight)	SAE 10W-30
JASO T903 standard	MA
others	without friction modifiers such as molybdenum additives
suggested oil*	Pro Honda GN4 4-stroke oil or an equivalent*

* Suggested 4-stroke engine oils are equal performance to SJ oils that are not labeled as energy conserving on the circular API service label.

- Your CRF does not need oil additives. Use the recommended oil.
- Do not use oils with graphite or molybdenum additives. They may adversely affect clutch operation.
- Do not use API SH or higher 4-stroke engine oils displaying a circular API “energy conserving” service label on the container. They may affect lubrication and clutch performance.

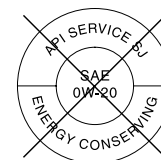

NOT RECOMMENDED

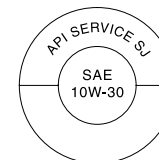

OK

- Oil is a major factor affecting the performance and service life of the transmission and clutch.

Other viscosities shown in the following chart may be used when the average temperature in your riding area is within the indicated range.

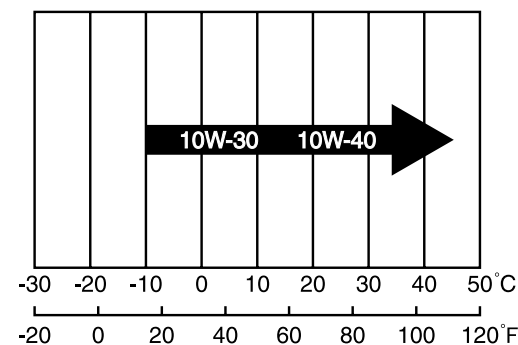

JASO T 903 standard

The JASO T 903 standard is an index for engine oils for 4-stroke motorcycle engines. There are two classes: MA and MB. Oil conforming to the standard is labeled on the oil container. For example, the following label shows the MA classification.

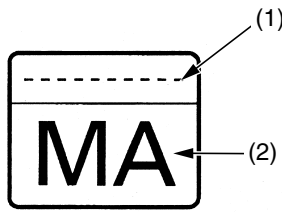

PRODUCT MEETING JASO T 903
COMPANY GUARANTEEING THIS MA PERFORMANCE:

- (1) code number of the sales company of the oil
(2) oil classification

Checking & Adding Oil

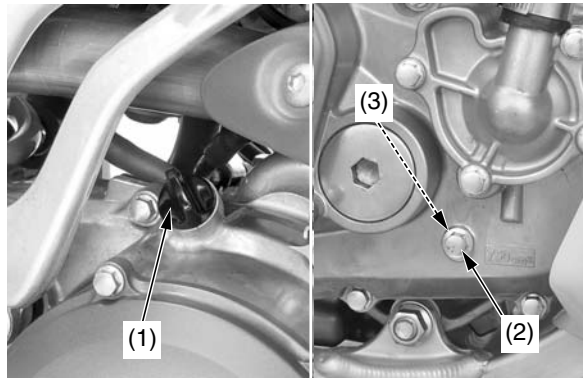

- (1) transmission oil filler cap (3) sealing washer
(2) oil check bolt

1. Run the engine at idle for 3 minutes, then shut it off.
2. Wait 3 minutes after shutting off the engine to allow the oil to properly distribute itself in the clutch and transmission.
3. Support the CRF in an upright position on a level surface.
4. Remove the transmission oil filler cap (1), oil check bolt (2) and sealing washer (3) from the right crankcase cover. A small amount of oil should flow out of the oil check bolt hole. Allow any excess oil to flow out of the oil check bolt hole. If no oil flows out of the oil check bolt hole, add oil slowly through the transmission oil filler hole until oil start to flow out of the oil check bolt hole. Tighten the oil check bolt with a new sealing washer and transmission oil filler cap. Repeat step 1-4.
5. After inspection the oil level or adding oil, tighten the oil check bolt to the specified torque:
Oil Check Bolt: 9 lbf-ft (12 N·m, 1.2 kgf·m)
6. Install the transmission oil filler cap securely.

Replacing Transmission Oil

1. Run the engine at idle for 3 minutes, then shut it off.
2. Support the CRF in an upright position on a level surface.
3. Remove the transmission oil filler cap (1) from the right crankcase cover.
4. Place an oil drain pan under the engine to catch the oil. Then remove the transmission oil drain bolt (2) and sealing washer (3).
5. After the oil has drained, apply fresh engine oil to the transmission oil drain bolt threads and tighten it with a new sealing washer to the specified torque:
12 lbf-ft (16 N·m, 1.6 kgf·m)
6. Fill the crankcase with recommended oil.
Capacity: 0.71 US qt (0.67 ℓ) at oil change
7. Check the transmission oil level by following the steps in *Checking & Adding Oil* (this page).

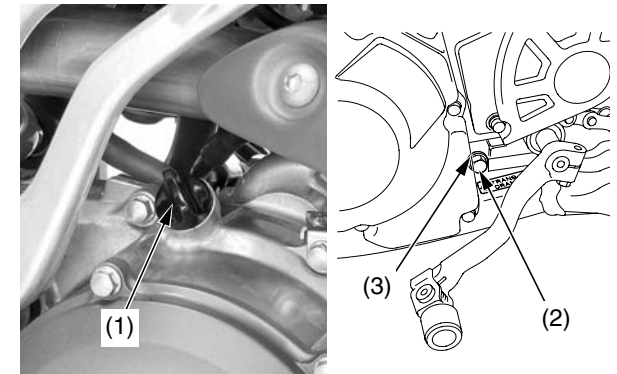

- (1) transmission oil filler cap
(2) transmission oil drain bolt
(3) sealing washer

Coolant

Your CRF's liquid cooling system dissipates engine heat through the coolant jacket that surrounds the cylinder and cylinder head.

Maintaining the coolant will allow the cooling system to work properly and prevent freezing, overheating, and corrosion.

Coolant Recommendation

Use Pro Honda HP Coolant or an equivalent high quality ethylene glycol antifreeze containing corrosion protection inhibitors specifically recommended for use in aluminum engines. Check the antifreeze container label.

Use only distilled water as a part of the coolant solution. Water that is high in mineral content or salt may be harmful to the aluminum engine.

NOTICE

Using coolant with silicate inhibitors may cause premature wear of water seals or blockage of radiator passages. Using tap water may cause engine damage.

The factory provides a 50/50 solution of antifreeze and water in this motorcycle. This coolant solution is recommended for most operating temperatures and provides good corrosion protection.

Decreasing the concentration of antifreeze to less than 40% will not provide proper corrosion protection.

Increasing the concentration of antifreeze is not recommended because it decreases cooling system performance. Higher concentrations of antifreeze (up to 60%) should only be used to provide additional protection against freezing. Check the cooling system frequently during freezing weather.

Checking & Adding Coolant

Refer to *Safety Precautions* on page 25.

1. With the engine at normal operating temperature, check the coolant level in the reserve tank. It should be between the UPPER (1) and LOWER (2) level marks. If the reserve tank (3) is empty, or if coolant loss is excessive, check for leaks and see your Honda dealer for repair.

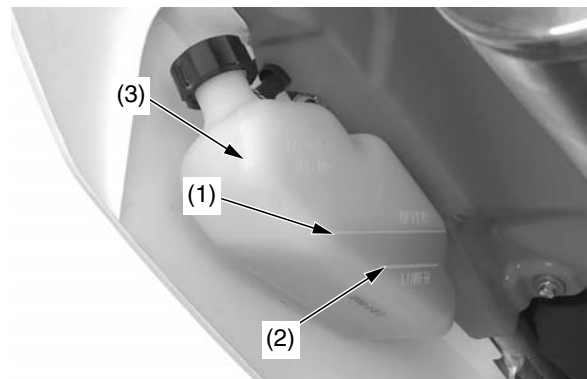

(1) UPPER level mark
(2) LOWER level mark
(3) reserve tank

2. Open the air cleaner housing cover (4) by turning the quick fastener (5) counterclockwise and remove the left side cover bolt (6), collar (7), seat mounting bolt (8) and left side cover (9).

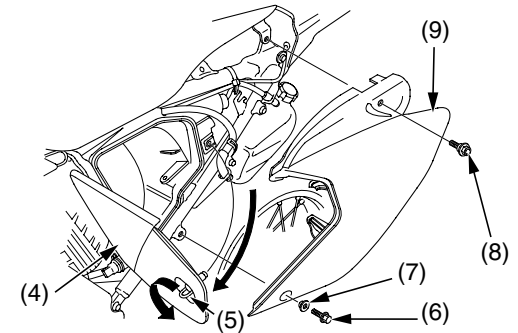

(4) air cleaner housing cover
(5) quick fastener
(6) left side cover bolt
(7) collar
(8) seat mounting bolt
(9) left side cover

3. Remove the reserve tank cap (10). Always add coolant to the reserve tank. Do not attempt to add coolant by removing the radiator cap.

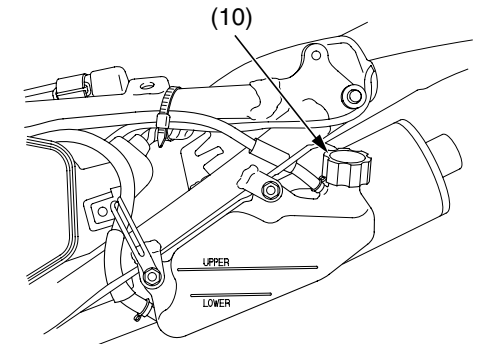

(10) reserve tank cap

4. Add coolant to the reserve tank as require to bring the coolant level to the UPPER level mark.
5. Install the reserve tank cap (10).
6. Install the left side cover (9), collar (7), seat mounting bolt (8) and left side cover bolt (6). Close the air cleaner housing cover (4) and turn the quick fastener (5) clockwise. Tighten the seat mounting bolt to the specified torque:
19 lbf-ft (26 N·m, 2.7 kgf-m)

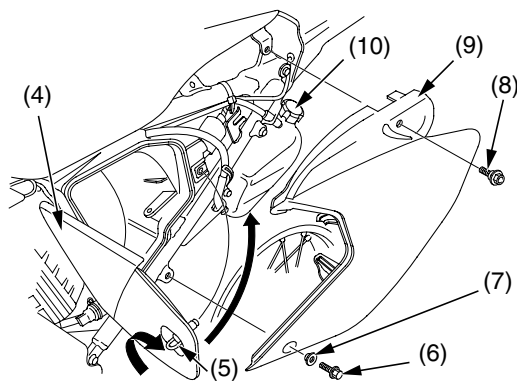

- (4) air cleaner housing cover
- (5) quick fastener
- (6) left side cover bolt
- (7) collar
- (8) seat mounting bolt
- (9) left side cover
- (10) reserve tank cap

Cooling System Inspection

1. Check the cooling system for leaks (see the Honda Service Manual for troubleshooting of leaks).
2. Check the water hoses (1) for cracks, deterioration, and radiator hose clamp for looseness.
3. Check the radiator mount for looseness.
4. Make sure the siphon hose (2) is connected and not clogged.
5. Check the radiator fins for clogging.
6. Check the water leakage check hole (3) below the water pump cover (4) for leakage. Make sure the hole remains open. If water leaks through the check hole, the water seal is damaged. If oil leaks through the check hole, the engine oil seal is damaged. See the Honda Service Manual or consult your Honda dealer for replacing the water seal or the engine oil seal. Both seals should be replaced at the same time.

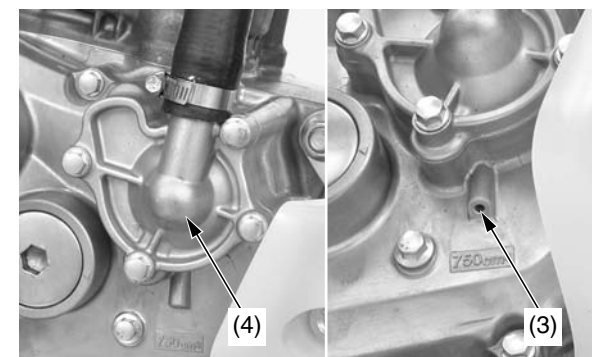
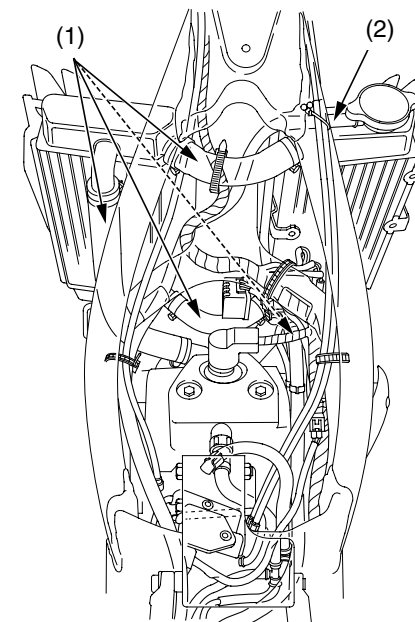

- (1) water hoses
- (2) siphon hose
- (3) water leakage check hole
- (4) water pump cover

Coolant

Coolant Replacement

Refer to *Safety Precautions* on page 25.

Coolant should be replaced by your Honda dealer, unless you have the proper tools and service data and are mechanically qualified. Refer to the Honda Service Manual (page 168).

▲ WARNING

Removing the radiator cap while the engine is hot can cause the coolant to spray out, seriously scalding you.

Always let the engine and radiator cool down before removing the radiator cap.

To properly dispose of drained coolant, refer to *You & the Environment*, page 143.

NOTICE

Improper disposal of drained fluids is harmful to the environment.

Coolant System Bleed Air

1. Remove the radiator cap (1).

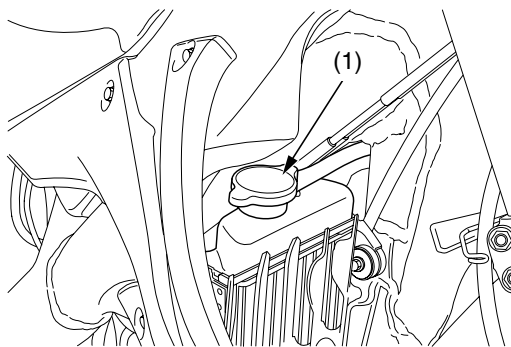

(1) radiator cap

2. Fill the system with the recommended coolant through the filler opening up to filler neck. Use a fresh recommended coolant mixture (page 48).

Capacity:

1.27 US qt (1.20 ℓ) at disassembly

1.19 US qt (1.13 ℓ) at coolant change

3. Turn the quick fastener (2) counterclockwise and open the air cleaner housing cover (3).
4. Remove the left side cover bolt (4), collar (5), seat mounting bolt (6) and left side cover (7).
5. Remove the reserve tank cap (8) and fill the reserve tank to the UPPER level line (9).

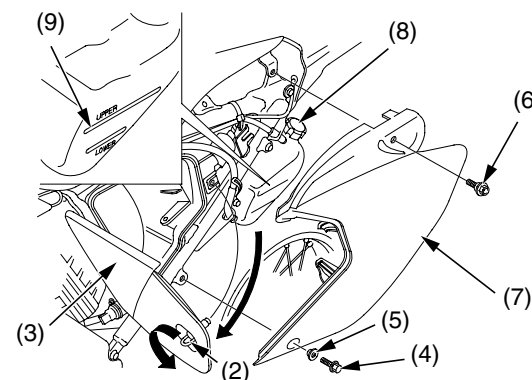

- | | |
|-------------------------------|------------------------|
| (2) quick fastener | (6) seat mounting bolt |
| (3) air cleaner housing cover | (7) left side cover |
| (4) left side cover bolt | (8) reserve tank cap |
| (5) collar | (9) UPPER level line |

6. Bleed air front the system as follows:
 - Shift the transmission into neutral. Start the engine and let it idle 2-3 minutes.
 - Snap the throttle three-four times to bleed air from the system.
 - Stop the engine and, if necessary, add coolant up to the proper level. Reinstall the radiator cap.
 - Check the level of coolant in the reserve tank and fill to the UPPER level if it is low.

NOTICE

If the radiator cap is not installed properly, it will cause excessive coolant loss and may result in overheating and engine damage.

7. Install the radiator reserve tank cap and left side cover, and close the air cleaner housing cover.

Refer to *Safety Precautions* on page 25.

The air cleaner uses polyurethane inner and outer pieces which can't be separated. A dirty air cleaner will reduce engine power.

Proper air cleaner maintenance is very important for off-road vehicles. A dirty, water-soaked, worn-out, or defective air cleaner will allow dirt, dust, mud, and other impurities to pass into the engine.

Service the air cleaner more frequently if you ride in unusually wet or dusty areas. Your Honda dealer can help you determine the correct service interval for your riding conditions.

Your CRF's air cleaner has very specific performance requirements. Use a new genuine Honda air cleaner specified for your model or an air cleaner of equal quality.

Proper air cleaner maintenance can prevent premature engine wear or damage, expensive repairs, low engine power, poor gas mileage, and spark plug fouling.

NOTICE

Improper or lack of proper air cleaner maintenance can cause poor performance and premature engine wear.

Cleaning

1. To open the air cleaner housing cover (1), turn the quick fastener (2) counterclockwise.

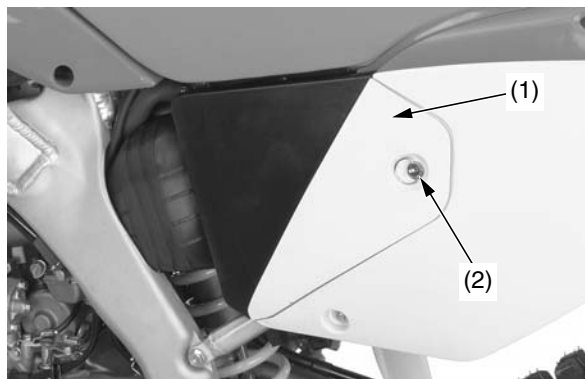

- (1) air cleaner housing cover
- (2) quick fastener

2. Remove the air cleaner retaining bolt (3) and air cleaner assembly (4) as shown.

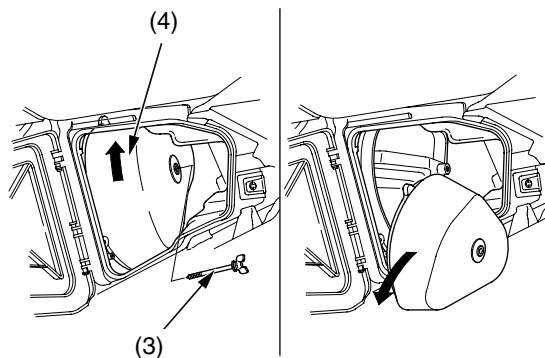

- (3) air cleaner retaining bolt
- (4) air cleaner assembly

3. Pull the air cleaner element (5) out from the air cleaner holder (6).

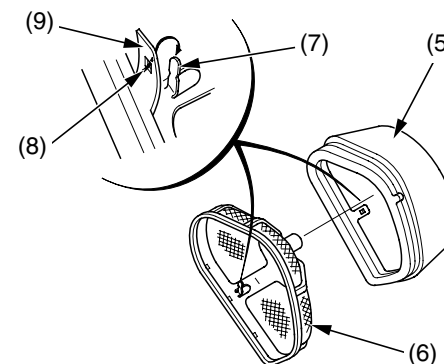

- (5) air cleaner element
- (6) air cleaner holder
- (7) tab
- (8) hole
- (9) air cleaner tab

4. Wash the air cleaner in clean non-flammable cleaning solvent. Then wash in hot, soapy water, rinse well, and allow to dry thoroughly. The air cleaner element is made in two pieces: inner and outer, which cannot be separated.
5. Clean the inside of the air cleaner housing.
6. Allow the air cleaner to dry thoroughly. After drying, soak the air cleaner element in clean Pro Honda Foam Filter Oil or an equivalent air cleaner oil. Apply air cleaner oil to the entire surface, inner and outer, and rub it with both hands to saturate the air cleaner with oil. Squeeze out excess oil.

(cont'd)

Air Cleaner

7. Apply a thin coat of Pro Honda White Lithium Grease or equivalent to the sealing surface.
8. Assemble the air cleaner element and holder. Install the tab (7) of the holder in the hole (8) of the air cleaner tab (9).
9. Install the air cleaner assembly into the air cleaner housing.
10. Carefully position the sealing flange of the element to prevent dirt intrusion. Align the access tab (10) of the air cleaner element with the “Δ” mark (11) of the air cleaner housing by rotating the air cleaner assembly counterclockwise. Install and tighten the air cleaner retaining bolt (3) securely.

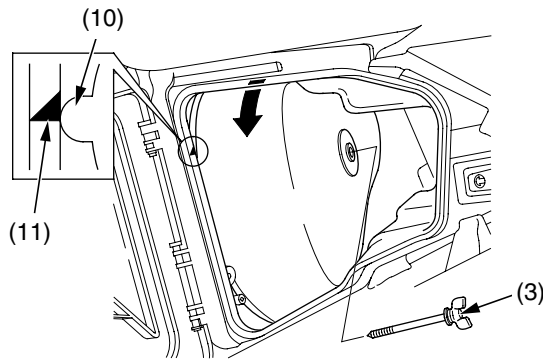

- (3) air cleaner retaining bolt
(10) access tab
(11) “Δ” mark

NOTICE

Improper installation of the air cleaner assembly may allow dirt and dust to enter the engine and cause rapid wear of the piston rings and cylinder.

11. Close the air cleaner housing cover (1) and turn the quick fastener (2) clockwise.

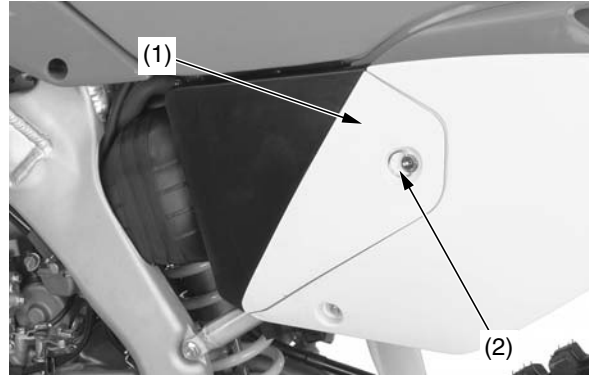

- (1) air cleaner housing cover
(2) quick fastener

Refer to *Safety Precautions* on page 25.

Crankcase Breather

Service more frequently if your CRF is ridden in the rain or often at full throttle.

Service the breather if you can see deposits in the transparent section of the drain tube.

1. Remove the crankcase breather tube plug (1) from the tube (2) and drain the deposits into a suitable container.
2. Reinstall the crankcase breather tube plug.

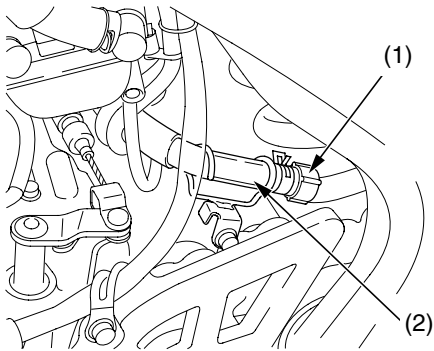

- (1) crankcase breather tube plug
(2) tube

Throttle

Refer to *Safety Precautions* on page 25.

Throttle Freeplay

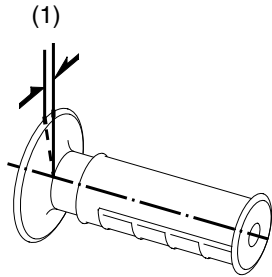

(1) freeplay

Inspection

Check freeplay (1).

Freeplay: 1/8 – 3/16 in (3 – 5 mm)

If necessary, adjust to the specified range.

Upper Adjustment

Minor adjustments are generally made with the upper adjuster.

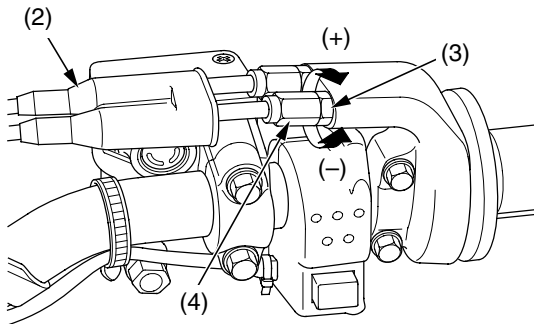

(2) dust cover
(3) upper lock nut
(4) upper adjuster

(+) increase
(-) decrease

1. Pull the dust cover (2) back.
2. Loosen the upper lock nut (3).
3. Turn the upper adjuster (4).
Turning the adjuster in direction (-) will decrease freeplay and turning it in direction (+) will increase freeplay.
4. Tighten the lock nut to the specified torque: 3.0 lbf·ft (4 N·m, 0.4 kgf·m)
Return the dust cover to its normal position.
5. After adjustment, check for smooth rotation of the throttle grip from fully closed to fully open in all steering positions.
If the adjuster is threaded out near its limit or the correct freeplay cannot be reached, turn the adjuster all the way in and back out one turn. Tighten the lock nut, install the dust cover and make the adjustment with the lower adjuster.

Lower Adjustment

The lower adjuster is used for major freeplay adjustment, such as after replacing the throttle cables or removing the carburetor. It is also used if you can not get the proper adjustment with the upper adjuster.

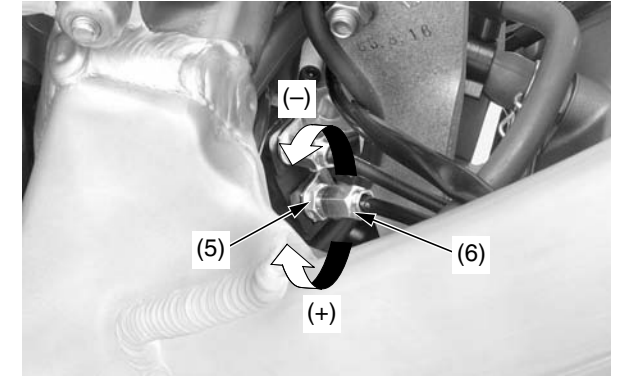

(5) lower lock nut
(6) lower adjuster

(+) increase
(-) decrease

1. Remove the fuel tank (page 37).
2. Loosen the lower lock nut (5).
3. Turn the lower adjuster (6) in direction (-) to decrease freeplay, and in direction (+) to increase freeplay.
4. Tighten the lock nut to the specified torque: 3.0 lbf·ft (4 N·m, 0.4 kgf·m)
5. Operate the throttle grip to ensure that it functions smoothly and returns completely.
6. Install the fuel tank (page 38)

If you can't get the freeplay within the specified range, contact your Honda dealer.

Throttle Inspection

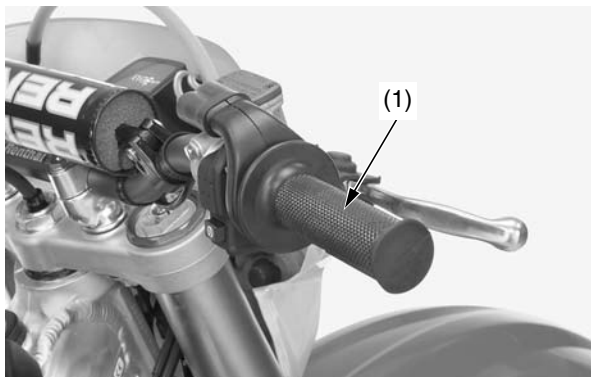

(1) throttle

1. Check that the throttle assembly is positioned properly and the securing bolts are tight.
2. Check for smooth rotation of the throttle (1) from fully open to fully closed in all steering positions. If there is a problem, see your Honda dealer.
3. Inspect the condition of the throttle cables from the throttle grip down to the carburetor. If the cable is kinked or chafed, have it replaced.
4. Check the cables for tension or stress in all steering positions.
5. Lubricate the cables with a commercially-available cable lubricant to prevent premature rust and corrosion.

Clutch System

Refer to *Safety Precautions* on page 25.

Clutch Freeplay

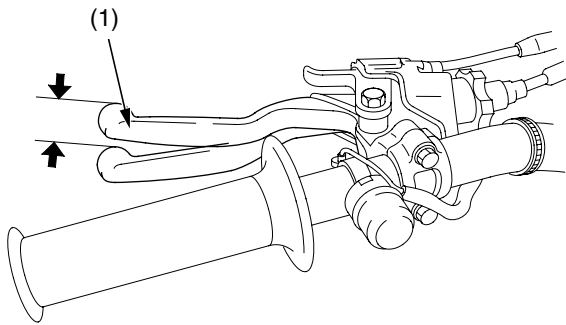

(1) clutch lever

Inspection

Check freeplay.

Freeplay: $\frac{3}{8}$ – $\frac{13}{16}$ in (10 – 20 mm)

If necessary, adjust to the specified range. Improper freeplay adjustment can cause premature clutch wear.

Make sure to adjust the clutch lever (1) freeplay after the clutch cable is disconnected.

Cable End Adjustment

Minor adjustments are generally made with the clutch cable end adjuster.

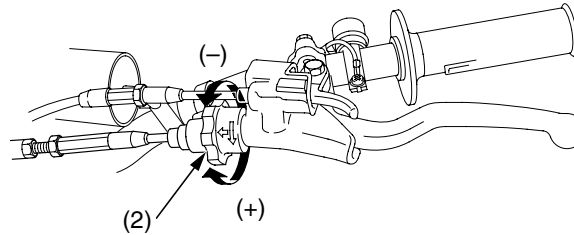

(2) cable end adjuster

(+) increase freeplay

(-) decrease freeplay

Turning the cable end adjuster (2) in direction (+) will increase freeplay and turning it in direction (-) will decrease freeplay.

If the adjuster is threaded out near its limit or the correct freeplay cannot be reached, turn the adjuster all the way in and back out one turn and make the adjustment with the integral cable adjuster.

Integral Cable Adjustment

The integral cable adjuster is used if the cable end adjuster is threaded out near its limit — or the correct freeplay cannot be obtained.

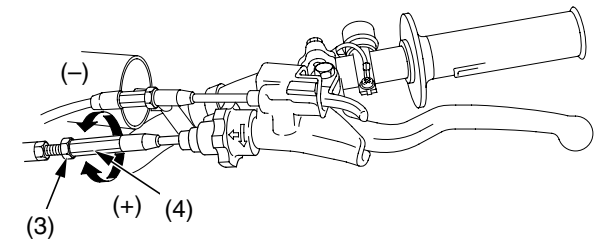

(3) lock nut

(4) integral cable adjuster

(+) increase

(-) decrease

1. Turn the cable end adjuster in direction (+) until it seats lightly and then turn it out 5 turns.
2. Loosen the lock nut (3).
3. Turn the integral cable adjuster (4) to obtain the specified freeplay.
4. Tighten the lock nut. Check the freeplay.
5. Start the engine, pull the clutch lever in, and shift into gear. Make sure the engine does not stall and the motorcycle does not creep. Gradually release the clutch lever and open the throttle. Your CRF should move smoothly and accelerate gradually.

If you can't get proper adjustment, or the clutch does not work properly, the cable may be kinked or worn, or the clutch discs may be worn. Inspect the clutch discs and plates (page 58).

Other Inspections & Lubrication

- Check that the clutch lever assembly is positioned properly (the end of the holder (1) aligned with the paint mark (2) on the handlebar) and the securing bolts are tight.

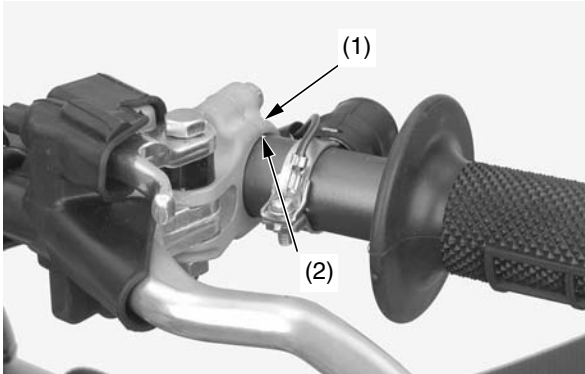

(1) holder (2) paint mark

- Check the clutch cable for kinks or signs of wear. If necessary, have it replaced.
- Lubricate the clutch cable with a commercially-available cable lubricant to prevent premature wear and corrosion.

Clutch Operation

1. Check for smooth clutch lever operation. If necessary, lubricate the clutch lever pivot or clutch cable.
2. Check the clutch cable for deterioration, kinks, or damage.

Clutch Cover/Disc/Plate Removal

1. Drain the transmission oil (page 47).
2. Remove the rear brake pedal (1) by removing the pin (2) and pivot bolt (3), washer (4) and dust seals (5).

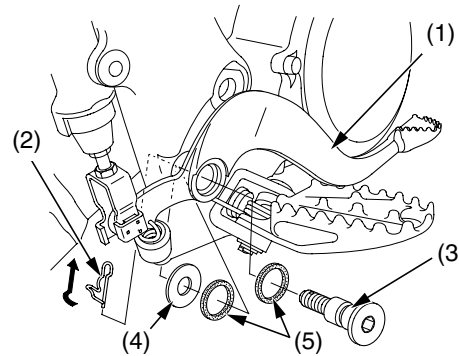

(1) rear brake pedal (2) pin
(3) pivot bolt (4) washer
(5) dust seals

3. Remove the five clutch cover bolts (6) and clutch cover (7).



(6) clutch cover bolts (7) clutch cover

4. Remove the five clutch spring bolts and clutch springs (8).

Loosen the bolts in a crisscross pattern in two or three progressive steps.

5. Remove the clutch pressure plate (9).

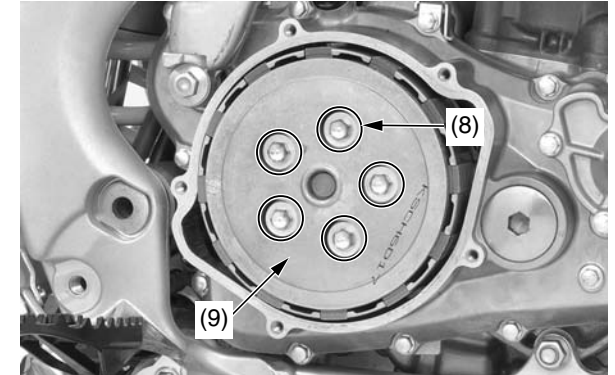

(8) clutch spring bolts/clutch springs
(9) clutch pressure plate

6. Remove the clutch lifter assembly (10) and clutch lifter rod (11).
7. Remove the eight clutch discs, seven clutch plates, judder spring and spring seat (12). Turn the lifter bearing plate of the clutch lifter bearing with your finger. The bearing plate should turn smoothly and quietly. Discard the clutch lifter if the bearing plate does not turn smoothly.

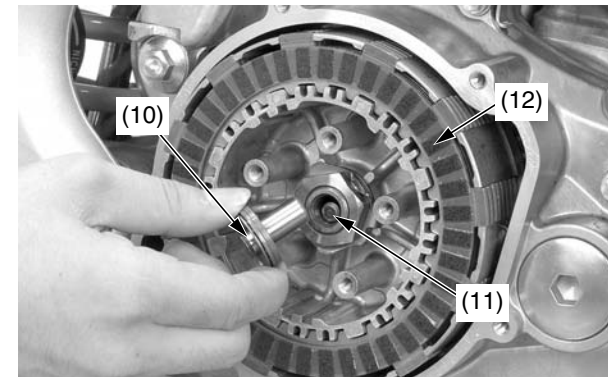

(10) clutch lifter assembly
(11) clutch lifter rod
(12) clutch discs, clutch plates, judder spring and spring seat

Clutch System

Clutch Disc/Plate Inspection

Replace the clutch discs (1) if they show signs of scoring or discoloration.

Measure the thickness of each clutch disc.

Service Limit: 0.112 in (2.85 mm)

Replace the clutch discs and clutch plates as a set.

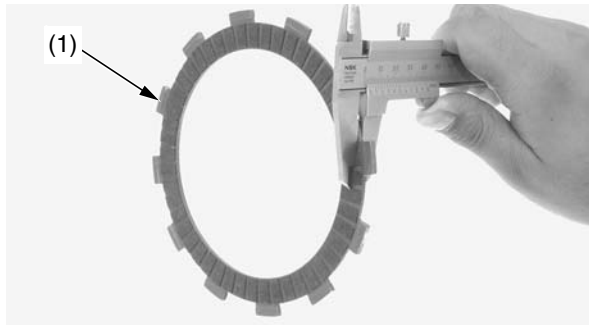

(1) clutch disc

Check the clutch plate (2) for excessive warpage or discoloration.

Check the plate warpage on a surface plate using a feeler gauge.

Measure the thickness of the clutch plates.

Service Limit: 0.004 in (0.10 mm)

Replace the clutch discs and plates as a set.

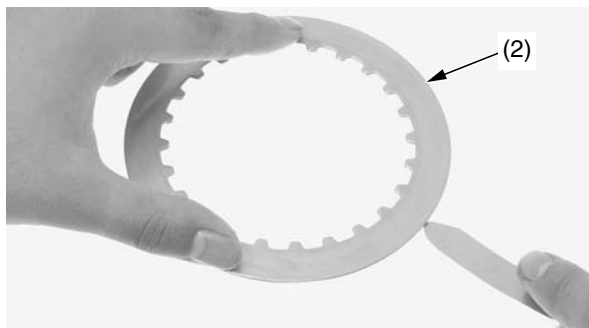

(2) clutch plate

Clutch Spring Inspection

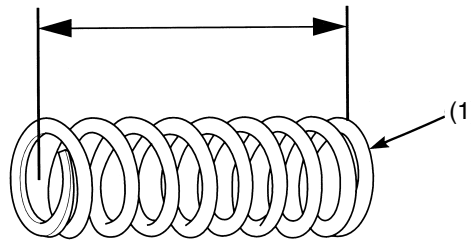

(1) clutch spring

Measure the free length of each spring.

Service Limit: 1.50 in (38.0 mm)

Replace the clutch springs as a set if any one of them is beyond the service limit or if the clutch plates have been burn/heat discolored.

Clutch Disc/Plate Installation

1. Install the spring seat (1) and judder spring (2) onto the clutch center as shown.

Coat the clutch discs (3) and plates (4) with clean engine oil.

2. Install the clutch disc A (larger I.D. disc) (5) onto the clutch outer.

Stack the seven clutch plates and seven clutch discs alternately.

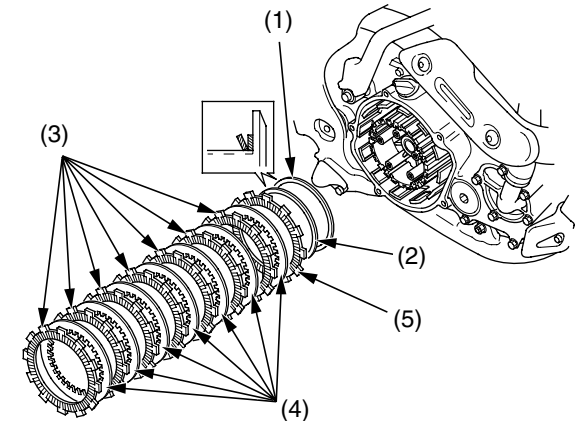

(1) spring seat

(2) judder spring

(3) clutch discs

(4) clutch plates

(5) clutch disc A

3. Insert the clutch lifter rod into the mainshaft.

4. Install the clutch lifter assembly (6) onto the rod.

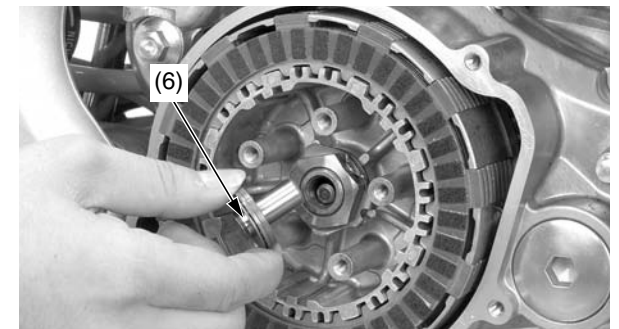

(6) clutch lifter assembly

5. Install the clutch pressure plate (7).
6. Install the five clutch springs and clutch spring bolts (8).
7. Tighten the bolts in a crisscross pattern in two or three steps to the specified torque:
9 lbf·ft (12 N·m, 1.2 kgf·m)

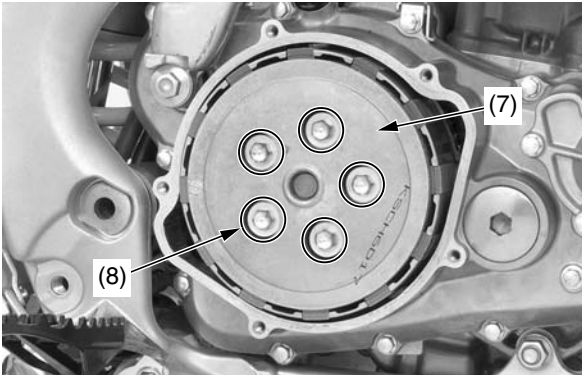

(7) clutch pressure plate
(8) clutch spring bolts/clutch springs

8. Install a new O-ring (9) in the groove of the clutch cover (10).
9. Install the clutch cover by tightening the clutch cover bolts to the specified torque:
7 lbf·ft (10 N·m, 1.0 kgf·m)

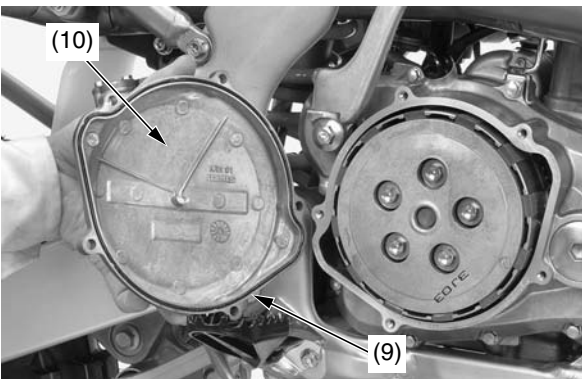

(9) O-ring (10) clutch cover

10. Apply grease to the rear brake pedal pivot bolt sliding surface.
11. Install the rear brake pedal (12), dust seals (11), washer (15) and pivot bolt (13) and tighten the pivot bolt to the specified torque:
27 lbf·ft (36 N·m, 3.7 kgf·m)

Connect the brake pedal return spring (14) if it was removed.

12. Insert the pin (16).

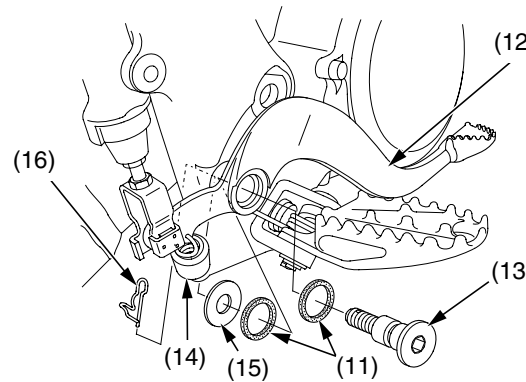

(11) dust seals (14) return spring
(12) rear brake pedal (15) washer
(13) pivot bolt (16) pin

13. Fill the crankcase with transmission oil (page 47).

Hot Start Lever

Refer to *Safety Precautions* on page 25.

Hot Start Lever Freeplay

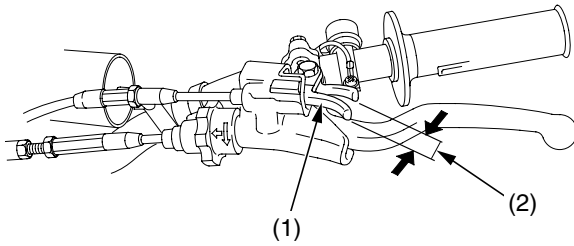

- (1) hot start lever
- (2) freeplay

Inspection

Check freeplay:

1/16 – 1/8 in (2 – 3 mm)

If necessary, adjust to the specified range.

Adjustment

Adjustments can be made with the cable end adjuster.

Loosen the lock nut (3) and turn the adjuster (4). Turning the adjuster in direction (+) will increase freeplay and turning it in direction (-) will decrease freeplay. After adjustment, tighten the lock nut.

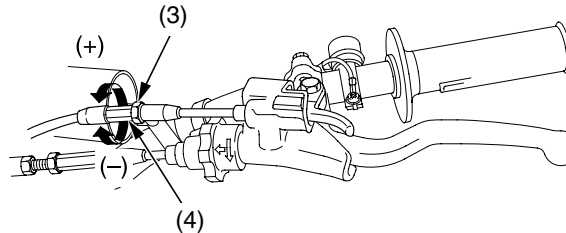

- (3) lock nut
- (4) adjuster

- (+) increase
- (-) decrease

Refer to *Safety Precautions* on page 25.

Spark Plug Recommendation

The recommended standard spark plug is satisfactory for most racing conditions.

Standard	IMR8C-9H (NGK) or VUH24D (DENSO)
Optional	IMR9C-9H (NGK) or VUH27D (DENSO)

Use only the recommended type of spark plugs in the recommended heat range.

NOTICE

Using a spark plug with an improper heat range or incorrect reach can cause engine damage. Using a non-resistor spark plug may cause ignition problems.

This motorcycle uses spark plug that have an iridium tip in center electrode and a platinum tip in side electrode.

Be sure to observe the following when servicing the spark plug.

- Do not clean the spark plug. If an electrode is contaminated with accumulated objects or dirt, replace the spark plug with a new one.
- To check the spark plug gap, use only a “wire-type feeler gauge”. To prevent damaging the iridium tip of the center electrode and platinum tip of the side electrode, never use a “leaf-type feeler gauge”.
- Do not adjust the spark plug gap. If the gap is out of specification, replace the spark plug with a new one.

Spark Plug Replacement & Inspection

1. Remove the seat and fuel tank (pages 36,37).
2. Disconnect the direct ignition coil (1).
3. Clean any dirt from around the spark plug base.
4. Remove the spark plug (2).

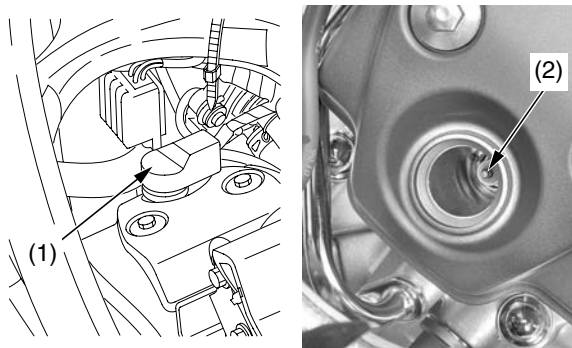

- (1) direct ignition coil
(2) spark plug

5. Check the electrodes for wear or deposits, the sealing gasket (3) for damage, and the insulator for cracks. Replace if you detect them.
6. Check the spark plug gap (4), using a wire-type feeler gauge. If the gap is out of specifications, replace the plug with a new one. The recommended spark plug gap is: 0.03 – 0.04 in (0.8 – 0.9 mm)

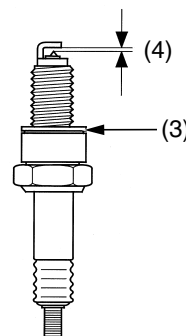

- (3) sealing gasket
(4) spark plug gap

7. To obtain accurate spark plug readings, accelerate up to speed on a straightaway. Push the engine stop button and disengage the clutch by pulling the lever in. Coast to a stop, then remove and inspect the spark plug. The porcelain insulator around the center electrode should appear tan or medium gray.

If you're using a new plug, ride for at least 10 minutes before taking a plug reading; a brand-new plug will not color initially.

If the electrodes appear burnt, or the insulator is white or light gray (lean) or the electrodes and insulator are black or fouled (rich), there is a problem elsewhere. Check the carburetor, fuel system and ignition timing.

8. With the plug washer attached. Thread the spark plug in by hand to prevent cross-threading.
9. Tighten the spark plug:
 - If the old plug is good: 1/8 turn after it seats.
 - If installing a new plug, tighten it twice to prevent loosening:
 - a) First, tighten the plug: NGK: 1/2 turn after it seats. DENSO: 1 turn after it seats.
 - b) Then loosen the plug.
 - c) Next, tighten the plug again: 1/8 turn after it seats.

NOTICE

An improperly tightened spark plug can damage the engine. If a plug is too loose, a piston may be damaged. If a plug is too tight, the threads may be damaged.

10. Connect the direct ignition coil. Take care to avoid pinching any cables or wires.
11. Install the fuel tank and seat (pages 36,38).

Exhaust Pipe/Muffler

Exhaust Pipe/Muffler Inspection

Check the flange bolts for tightness.
Check the exhaust pipe and muffler for cracks or deformation.
A damaged exhaust pipe and muffler may reduce engine performance.

Muffler Removal

1. Remove the seat mounting bolt (1), side cover bolt (2), collar (3) and right side cover (4).

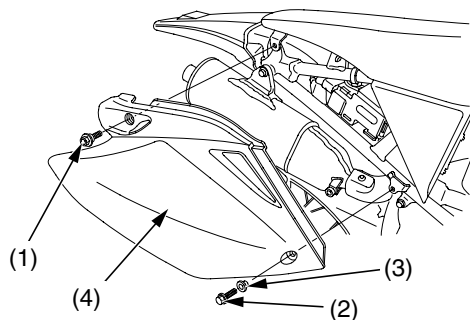

- | | |
|------------------------|----------------------|
| (1) seat mounting bolt | (3) collar |
| (2) side cover bolt | (4) right side cover |

2. Loosen the muffler clamp bolt (5).
3. Remove the muffler A bolt/washer (6), muffler B bolt (7) and muffler (8).

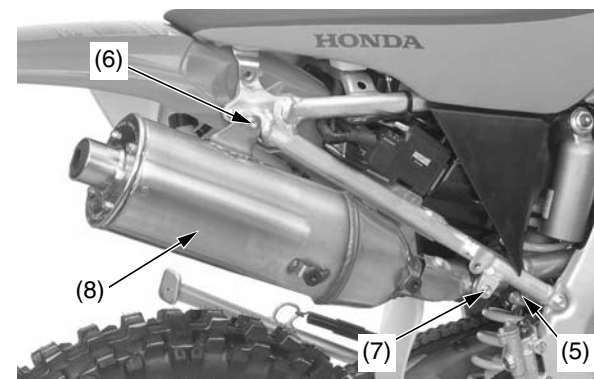

- | | |
|---------------------------|--------------------|
| (5) muffler clamp bolt | (7) muffler B bolt |
| (6) muffler A bolt/washer | (8) muffler |

Muffler Installation

1. Remove the gasket.
2. Install a new gasket (1) on to the exhaust pipe.
3. Install the muffler clamp (2) by aligning the tab (4) of the muffler clamp with the cut-out (5) of the muffler (3).
4. Install the muffler.

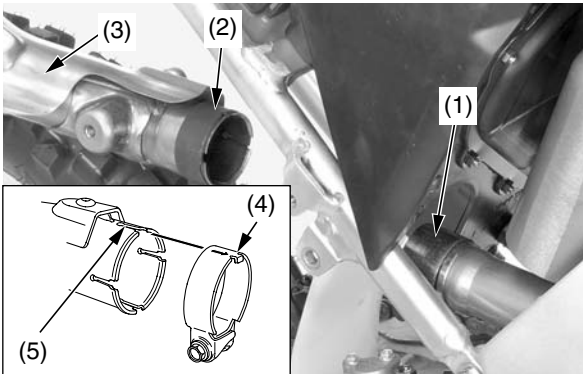

- (1) gasket
 (2) muffler clamp
 (3) muffler
- (4) tab
 (5) cut-out

5. Tighten the muffler B bolt (6) and muffler A bolt/washer (7) to the specified torque:
 19 lbf-ft (26 N·m, 2.7 kgf·m)
6. Tighten the muffler clamp bolt (8) to the specified torque:
 15 lbf-ft (21 N·m, 2.1 kgf·m)

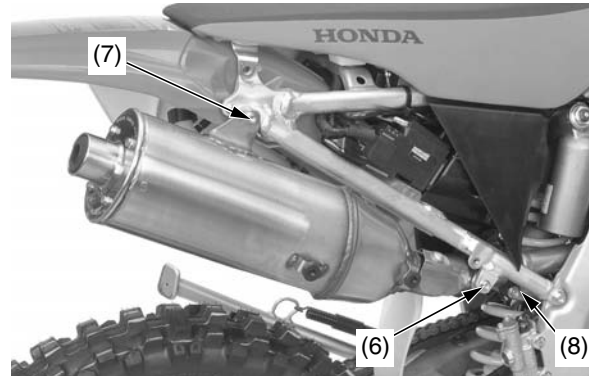

- (6) muffler B bolt
 (7) muffler A bolt/washer
- (8) muffler clamp bolt

7. Install the right side cover (9), collar (10) and side cover bolt (11).
8. Install the seat mounting bolt (12) and tighten it to the specified torque:
 19 lbf-ft (26 N·m, 2.7 kgf·m)

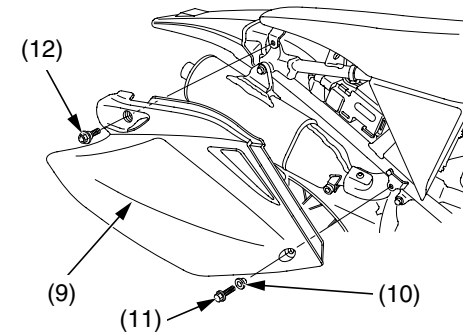

- (9) right side cover
 (10) collar
- (11) side cover bolt
 (12) seat mounting bolt

Exhaust Pipe/Muffler

Exhaust Pipe Removal

1. Remove the muffler (page 62).
2. Remove the exhaust pipe joint nuts (1), exhaust pipe (2) and exhaust pipe gasket (3).

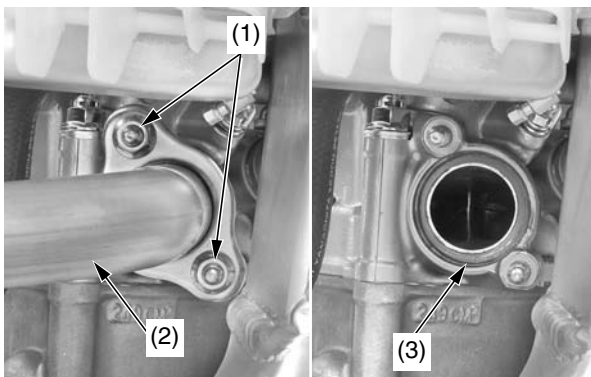

- (1) exhaust pipe joint nuts
- (2) exhaust pipe
- (3) exhaust pipe gasket

Exhaust Pipe Installation

1. Install a new exhaust pipe gasket (1), exhaust pipe (2) and exhaust pipe joint nuts (3) and tighten the nuts to the specified torque:
15 lbf-ft (21 N·m, 2.1 kgf·m)

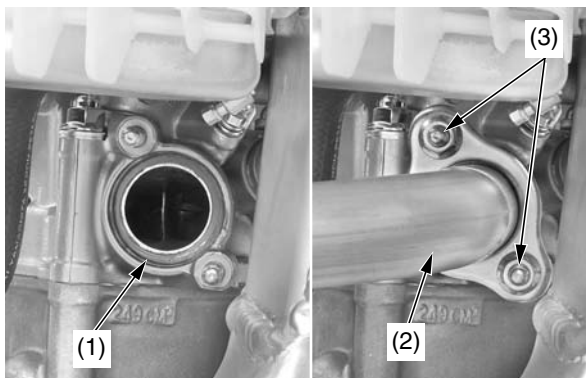

- (1) exhaust pipe gasket
- (2) exhaust pipe
- (3) exhaust pipe joint nuts

2. Install the muffler (page 63).

Spark Arrester Inspection

The spark arrester must be serviced every 1,000 mi (1,600 km) of running or 100 operating hours to maintain its efficiency.

Regular servicing prevents carbon buildup (which can diminish engine performance) and also complies with USDA regulations for regular maintenance to assure proper function. The spark arrester prevents random sparks from the combustion process in your engine from reaching the environment.

1. Allow the engine and muffler (1) to cool.
2. Remove the bolts (2), spark arrester (3), and gasket (4) from the muffler.

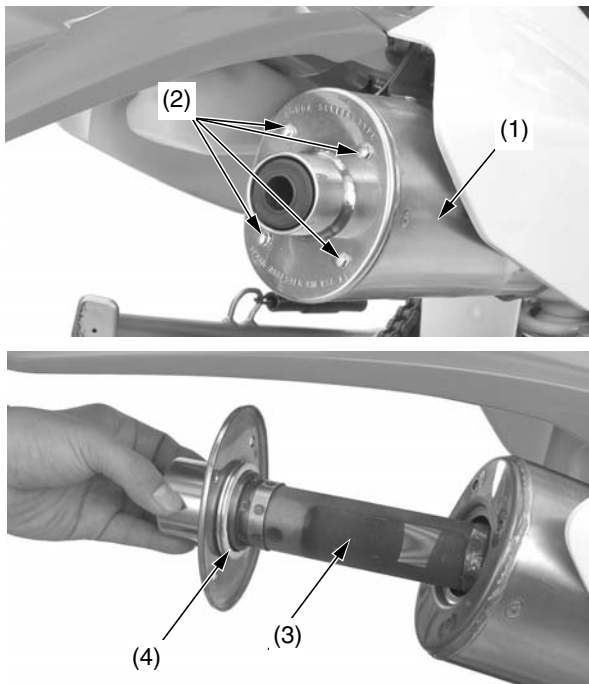

(1) muffler
(2) bolts
(3) spark arrester
(4) gasket

3. Use a brush to remove carbon deposits from the spark arrester screen. Be careful to avoid damaging the spark arrester screen. The spark arrester must be free of brakes and holes. Replace, if necessary. Check the gasket. Replace, if necessary.

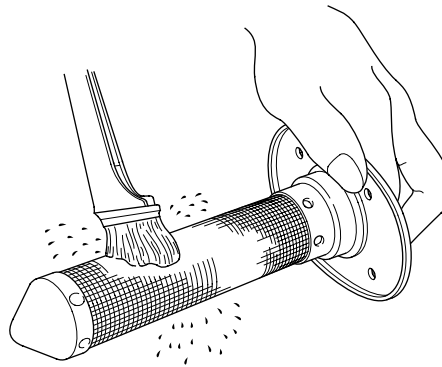

4. Apply a seizure inhibitor (Three Bond 1901 or equivalent) to the bolts threads. Install the spark arrester and gasket in the muffler (1) and tighten the bolts (2) to the specified torque:
4.4 lbf-ft (6 N·m, 0.6 kgf·m)

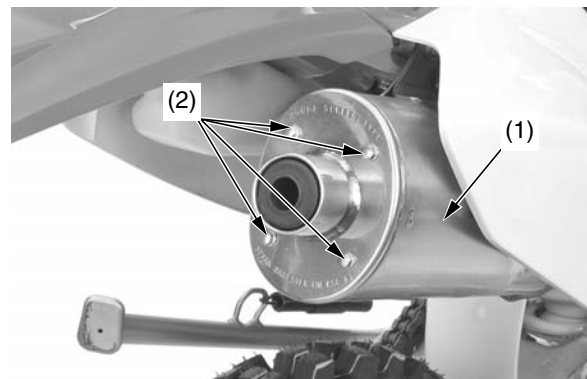

(1) muffler
(2) bolts

Valve Clearance

Refer to *Safety Precautions* on page 25.

Excessive valve clearance will cause noise and eventual engine damage. Little or no clearance will prevent the valve from closing and cause valve damage and power loss. Check the valve clearance when the engine is cold at the intervals specified in the Maintenance Schedule (pages 27, 28).

The checking or adjusting of the valve clearance should be performed while the engine is cold. The valve clearance will change as engine temperature rises.

Cylinder Head Cover Removal

Before inspection, clean the engine thoroughly to keep dirt from entering the engine.

1. Remove the seat (page 36).
2. Remove the fuel tank (page 37).
3. Disconnect the breather tube (1) and direct ignition coil (2).

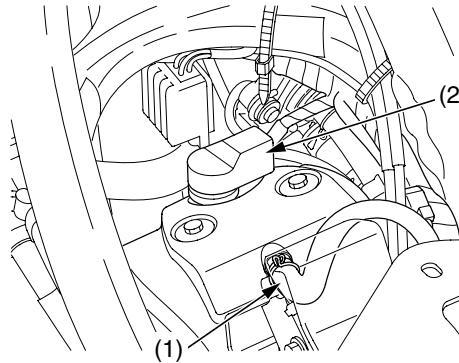

- (1) breather tube (2) direct ignition coil

4. Remove the cylinder head cover bolts/rubber seals (3), and cylinder head cover (4).

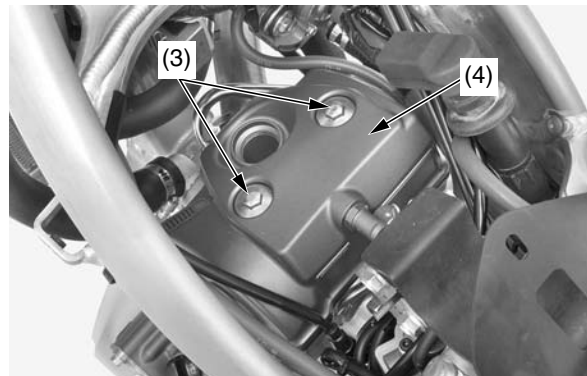

- (3) cylinder head cover bolts/rubber seals
(4) cylinder head cover

Positioning At Top Dead Center On The Compression Stroke

1. Remove the crankshaft hole cap (1).

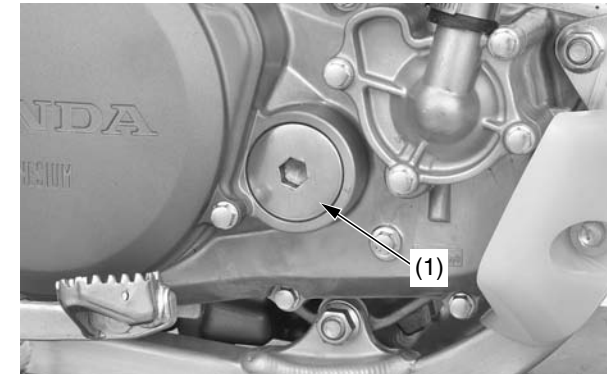

- (1) crankshaft hole cap

- Rotate the crankshaft by turning the primary drive gear (2) clockwise until aligning the punch mark (3) on the primary drive gear with the "Δ" mark (4) on the right crankcase cover. In this position, the piston may either be on the compression or exhaust stroke. If the crankshaft passed the punch mark, rotate the primary drive gear bolt clockwise again and align the punch mark with the "Δ" mark. The inspection must be made when the piston is at the top of the compression stroke when both the intake and exhaust valves are closed. This condition can be determined by moving the exhaust rocker arm (5). If it is free, it is an indication that the valves are closed and that the piston is on the compression stroke. If it is tight and the valves are open, rotate the primary drive gear lock bolt 360° and realign the punch mark to the "Δ" mark.

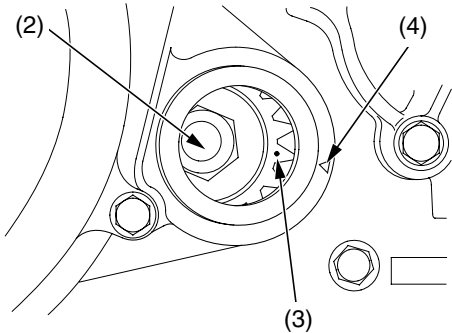

- (2) primary drive gear bolt
 (3) punch mark
 (4) "Δ" mark



- (5) exhaust rocker arm

Valve Clearance Inspection

- Measure the intake valve clearance by inserting a feeler gauge (1) between the valve lifters (2) and intake cam lobe (3).

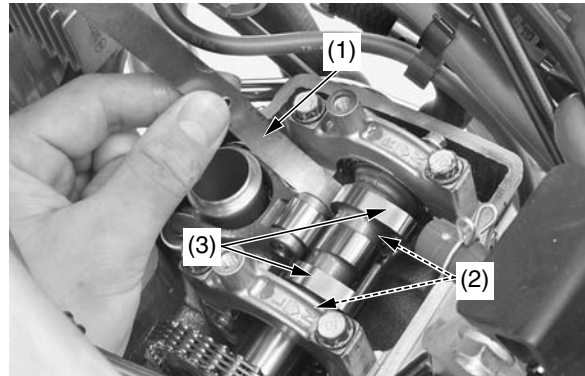

- (1) feeler gauge
 (2) valve lifters
 (3) intake cam lobe

- Measure the exhaust valve clearance by inserting a feeler gauge (1) between the exhaust rocker arm (4) and shims (5).

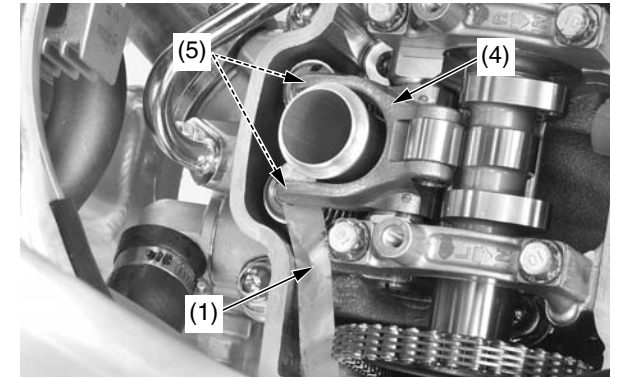

- (1) feeler gauge
 (4) exhaust rocker arm
 (5) exhaust valve shims

Valve Clearances:

IN: 0.005 ± 0.001 in (0.12 ± 0.03 mm)
 EX: 0.011 ± 0.001 in (0.28 ± 0.03 mm)

If intake valve clearance and exhaust valve clearance need adjustment, see *Camshaft Removal* (page 68) and select the correct shim for each valve.

Valve Clearance

Camshaft Removal

1. Record the intake valve clearance and exhaust valve clearance.

2. Remove the cam chain tensioner lifter cover bolt (1) and sealing washer (2).

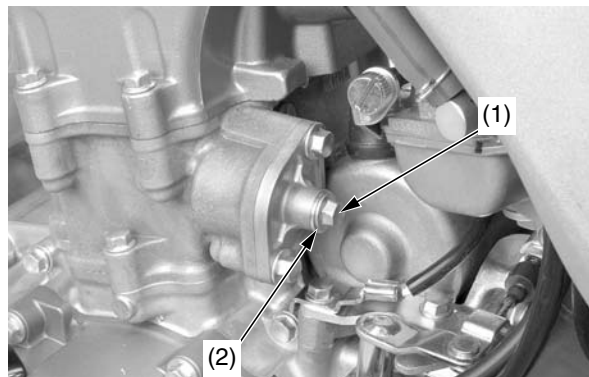

- (1) cam chain tensioner lifter cover bolt
(2) sealing washer

Use the tensioner stopper tool.

- Tensioner stopper 070MG-0010100

3. Turn the tensioner shaft clockwise with the stopper tool (3) until it stops, in order to retract the tensioner fully.
Then insert the stopper tool fully to hold the stopper in the fully retracted position.

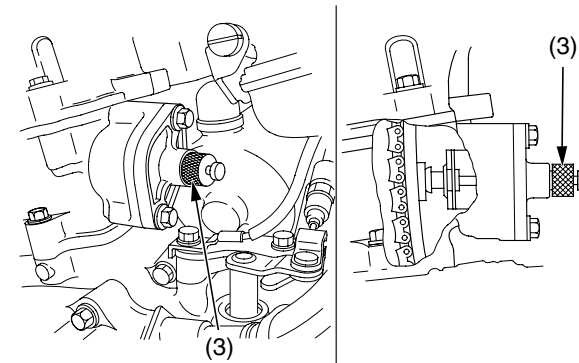

- (3) stopper tool

4. Remove the camshaft holder bolts (4) and camshaft holders (5).

Loosen the camshaft holder bolts in a criss-cross pattern in two or three steps.

5. Remove the camshaft (6), and then attach a piece of wire to the cam chain to prevent it from falling into the crankcase.

Be careful not let the set rings of the camshaft holders fall into the crankcase.

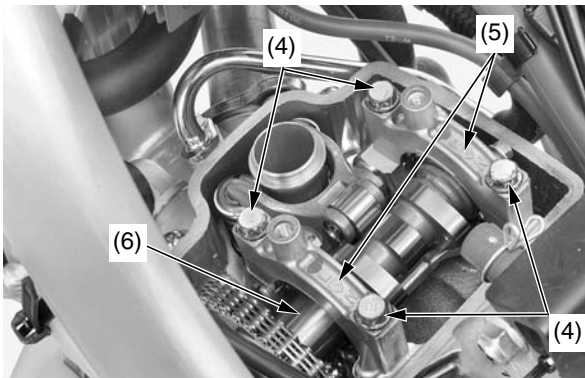

(4) camshaft holder bolts (6) camshaft
(5) camshaft holders

6. Remove the valve lifters (7).

Position the removed intake valve lifters and shims to indicate their location such as intake or exhaust, right or left.

NOTICE

Do not let the valve lifters and shims fall into the crankcase.

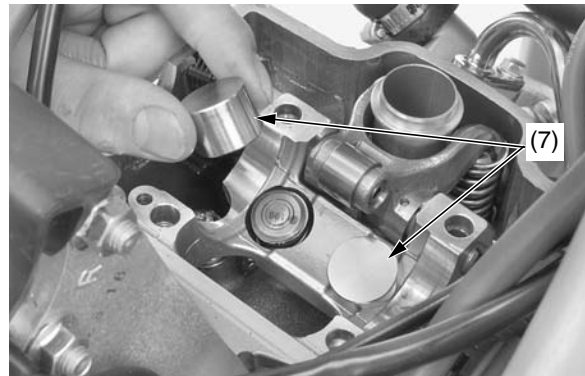

(7) valve lifters

7. Remove the shims (8).

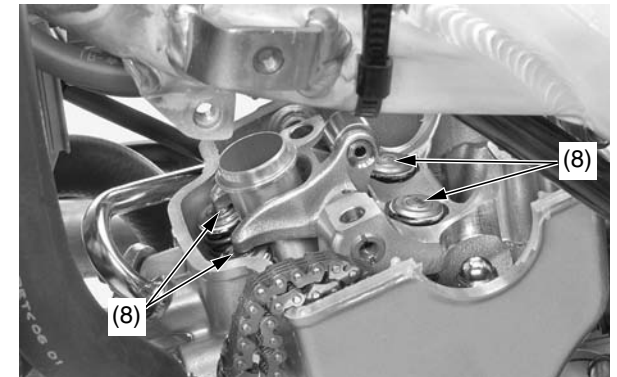

(8) shims

Valve Clearance

Shim Selection

1. Clean the valve shim contact area in the valve lifter (1) with compressed air.

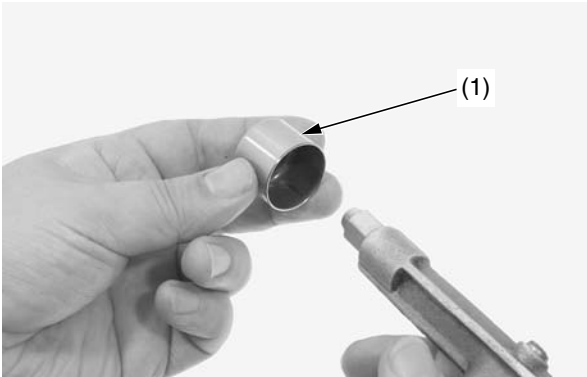

(1) valve lifter

2. Measure the shim thickness with a micrometer and record it.
Sixty-nine different thickness shims (2) are available from the thinnest (1.200 mm thickness) shim to the thickest (2.900 mm thickness) in intervals of 0.025 mm.

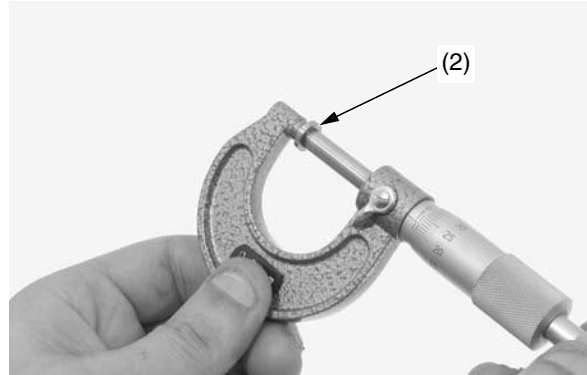

(2) shim

3. Calculate the new shim thickness using the equation below.

$$A = (B - C) + D$$

- A: New shim thickness
B: Recorded valve clearance
C: Specified valve clearance
D: Old shim thickness

- Make sure of the correct shim thickness by measuring the shim with a micrometer.
- Reface the intake valve seat if carbon deposits result in a calculated dimension of over 2.450 mm.
Reface the exhaust valve seat if carbon deposits result in a calculated dimension of over 2.900 mm.

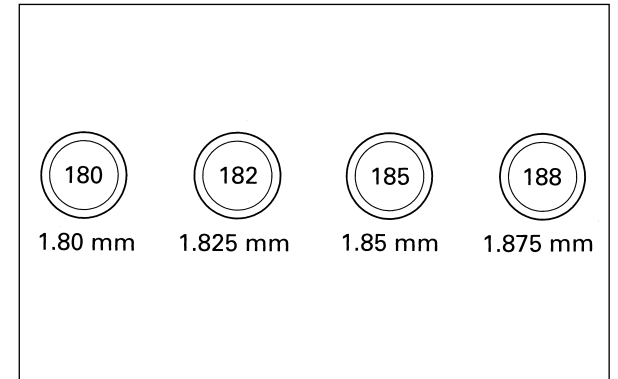

Camshaft Installation

1. Install the newly selected shims (1) on the valve retainers (2).

NOTICE

Do not let the shims fall into the crankcase.

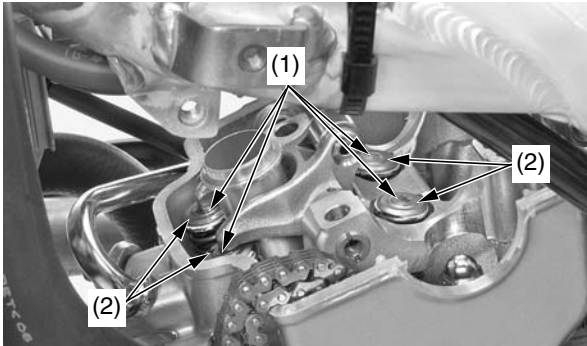

(1) shims (2) valve retainers

2. Apply molybdenum disulfide oil solution (a mixture of 1/2 engine oil and 1/2 molybdenum disulfide grease containing more than 3% molybdenum disulfide additive) to outer surface of the each valve lifters. Install the valve lifters (3).

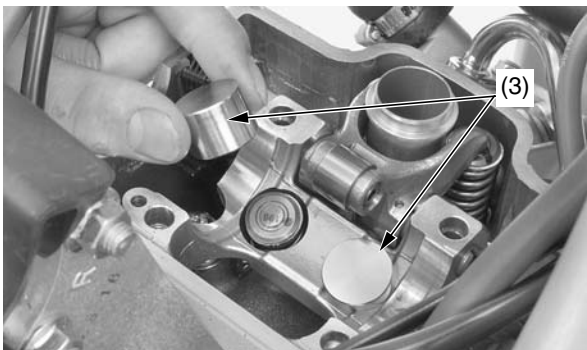

(3) valve lifters

3. Rotate the primary drive gear bolt (4) (crankshaft) clockwise and align the punch mark (5) with the "Δ" mark (6).

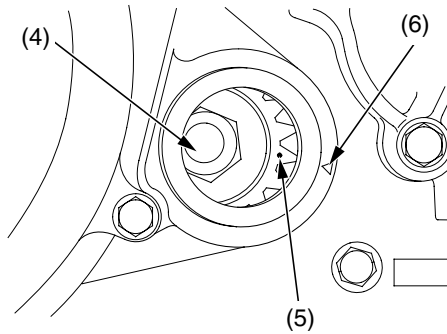

(4) primary drive gear bolt
(5) punch mark
(6) "Δ" mark

4. Apply molybdenum oil solution to the camshaft journals and cam lobes. Place the cam sprocket (7) and align the timing marks (8) on the cam sprocket with the top surface of the cylinder head (9). Install the cam chain (10) over the sprocket without rotating the sprocket.

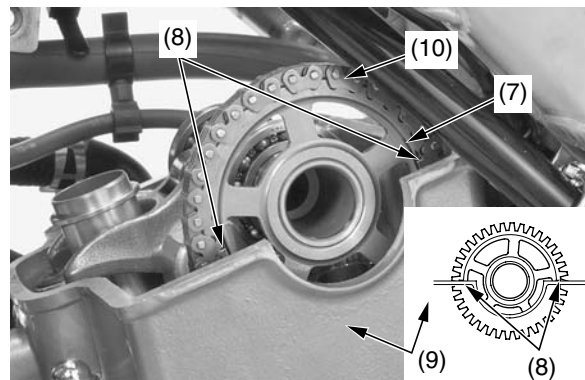

(7) cam sprocket (9) cylinder head
(8) timing marks (10) cam chain

5. Apply grease to the set rings and install it onto the camshaft holders (11). Apply oil to the camshaft holder bolt threads and seating surface. Install the camshaft holder bolts (12) and tighten it to the specified torque: 12 lbf-ft (16 N·m, 1.6 kgf·m)

Tighten the camshaft holder bolts in a criss-cross pattern in two or three steps.

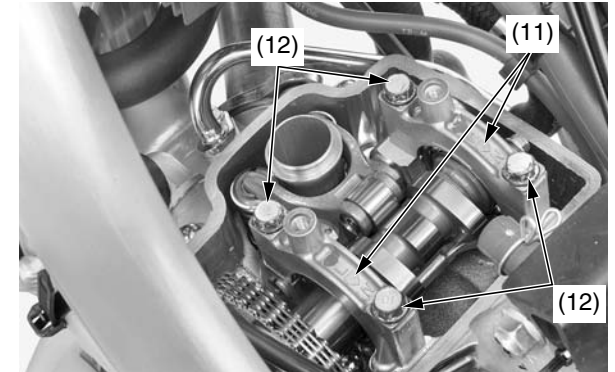

(11) camshaft holders (12) camshaft holder bolts

(cont'd)

Valve Clearance

6. Insert the feeler gauge between the intake valve lifter and cam lobe.
If the feeler gauge (13) cannot be inserted, the shim is caught between the valve lifter and the valve retainer. Remove the camshaft holders to place the shim correctly, and reinstall the camshaft holders.

Valve Clearance:

IN: 0.005 ± 0.001 in (0.12 ± 0.03 mm)

EX: 0.011 ± 0.001 in (0.28 ± 0.03 mm)

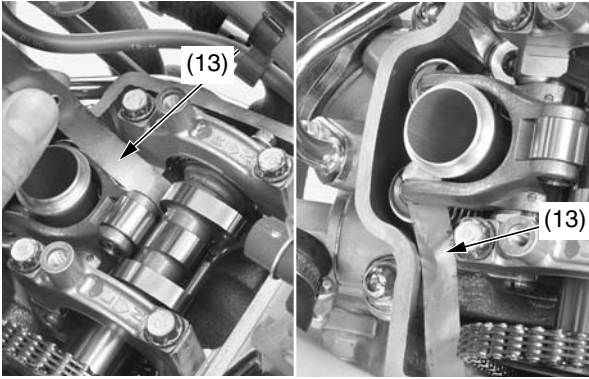

(13) feeler gauge

7. Remove the stopper tool (14) from the cam chain tensioner lifter.

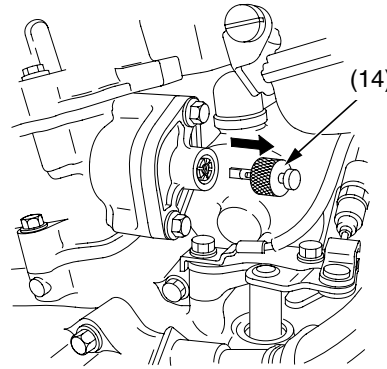

(14) stopper tool

8. Install a new sealing washer (15) and tighten the cam chain tensioner lifter cover bolt (16).

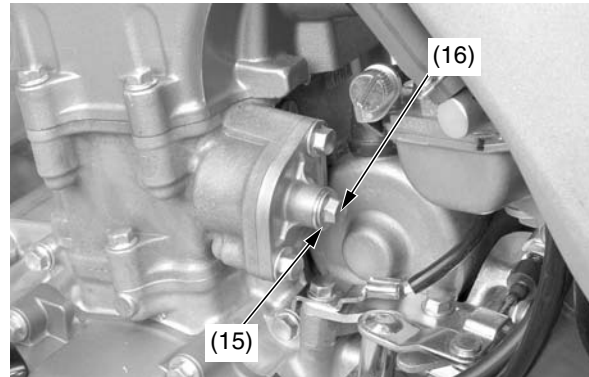

(15) sealing washer

(16) cam chain tensioner lifter cover bolt

Crankshaft Hole Cap Installation

Coat a new O-ring (1) with engine oil and install it onto the crankshaft hole cap (2).

Apply grease to the crankshaft hole cap threads. Install and tighten the crankshaft hole cap to the specified torque:

11 lbf·ft (15 N·m, 1.5 kgf·m)

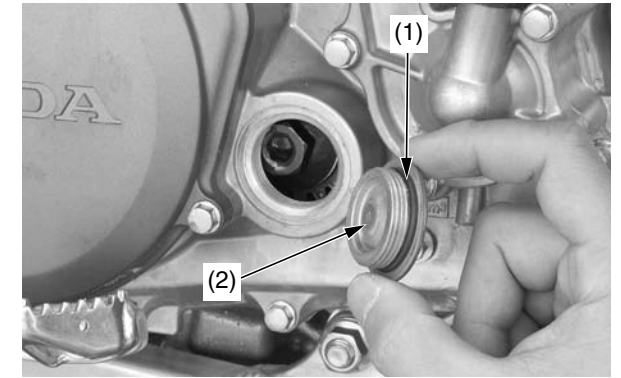

(1) O-ring

(2) crankshaft hole cap

Cylinder Head Cover Installation

1. Check the spark plug hole packing (1) is in good condition, replace it if necessary. Apply engine oil to the spark plug hole packing and install it to the spark plug hole (2).

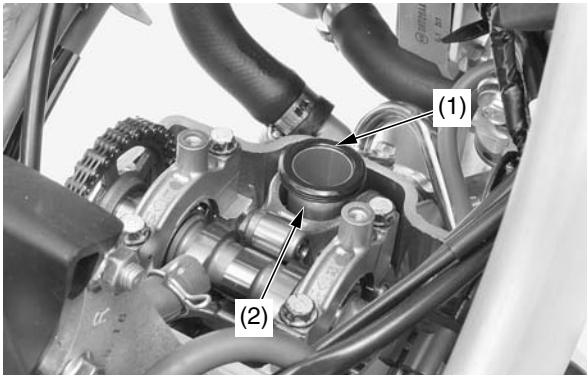

(1) spark plug hole packing
(2) spark plug hole

2. Inspect the cylinder head cover packing (3) for damage or deterioration, replace it if necessary. Install the cylinder head cover packing into the groove of the cylinder head cover (4).

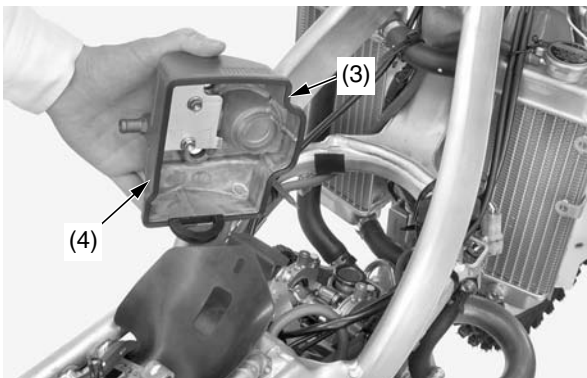

(3) cylinder head cover packing
(4) cylinder head cover

3. Check the rubber seals (5) are in good condition, replace them if necessary. Install the rubber seals onto the cylinder head cover with the "UP" marks (6) facing up.

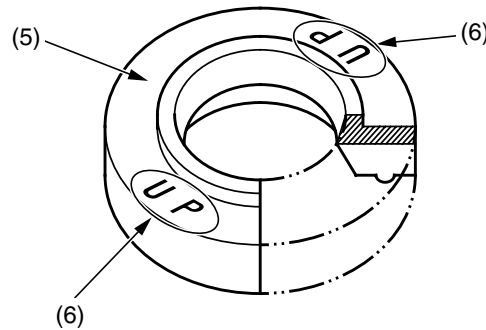

(5) rubber seal
(6) "UP" marks

4. Install the cylinder head cover (4) and tighten the cylinder head cover bolts (7) to the specified torque:
7 lbf·ft (10 N·m, 1.0 kgf·m)

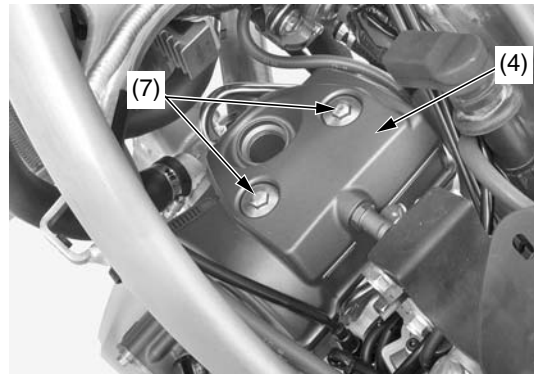

(4) cylinder head cover
(7) cylinder head cover bolts

5. Connect the direct ignition coil (8) and breather tube (9).

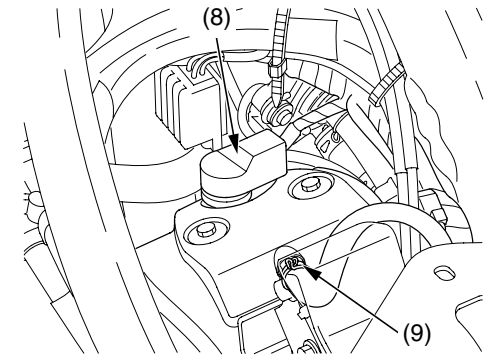

(8) direct ignition coil
(9) breather tube

6. Install the fuel tank and the seat (pages 36, 38).

Piston/Piston Rings/Piston Pin

Cylinder Head Removal

1. Clean the area above the engine before disassembly to prevent dirt falling into the engine.
2. Drain the engine oil (page 44).
3. Drain the radiator coolant after cooling the motorcycle (page 141).
4. Remove the seat and fuel tank (pages 36,37).
5. Lift the subframe to the upright position (page 39).
6. Remove the carburetor (page 130).
7. Remove the exhaust pipe (page 64).
8. Disconnect the air suction (1) and vacuum hoses (2).
9. Remove the air supply pipe bolt (3), PAIR control valve bolts/nuts (4) and PAIR control valve (5).

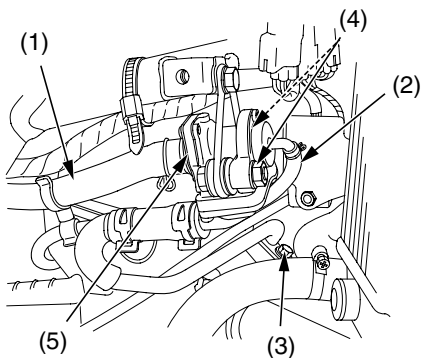

- (1) air suction hose (4) PAIR control valve bolts/nuts
(2) vacuum hose (5) PAIR control valve
(3) air supply pipe bolt

10. Disconnect the direct ignition coil (5).
11. Remove any dirt around the spark plug base.

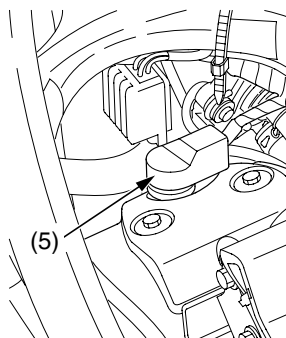

(5) direct ignition coil

12. Remove the cylinder head cover (page 66).
13. Remove the spark plug (6).

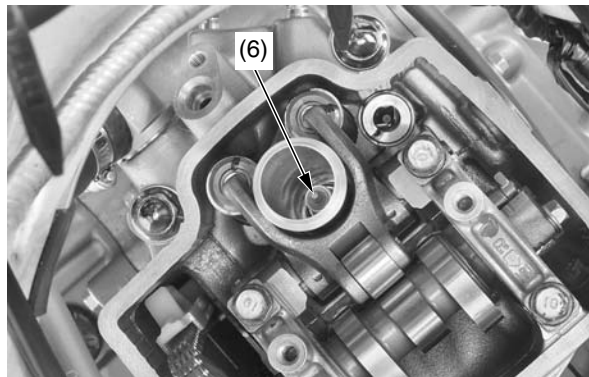

(6) spark plug

14. Position the piston to top dead center on the compression stroke (page 66). Remove the camshaft (page 68).
15. Loosen the radiator hose clamp (7) and disconnect the radiator hose (8).

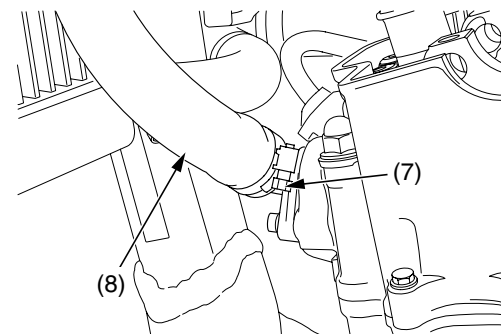

(7) radiator hose clamp
(8) radiator hose

16. Remove the engine hanger nuts/bolts (9) and engine hanger plates (10).

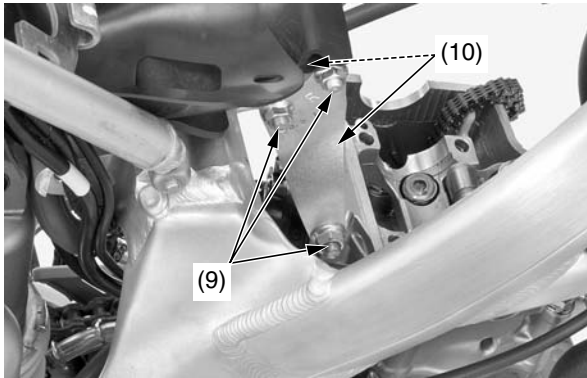

(9) engine hanger nuts/bolts
(10) engine hanger plates

17. Remove the cylinder head bolts (11).
18. Loosen the cylinder bolt (12).

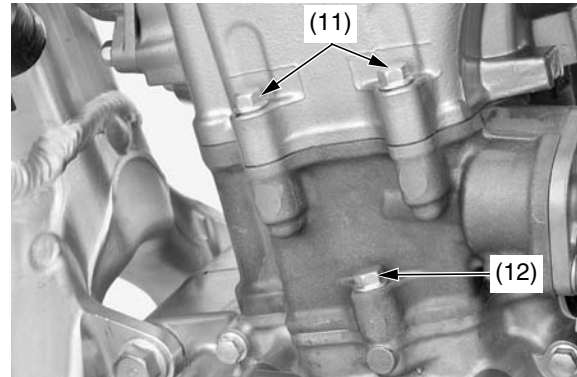

(11) cylinder head bolts
(12) cylinder bolt

19. Remove the cylinder head nuts/washers (13) and cylinder head (14).
Loosen the nuts in a criss-cross pattern in two or three steps.

NOTICE

Do not let the nuts, washers, valve lifters, shims, and cam chain fall into the crankcase.

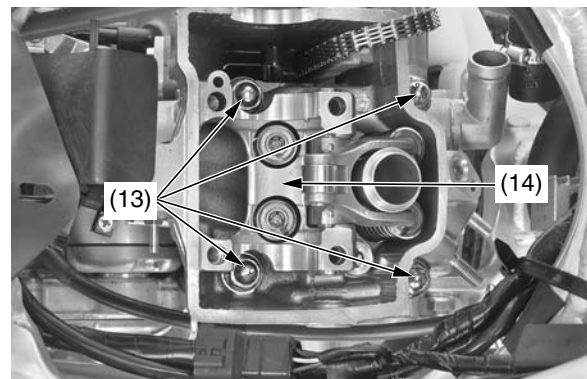

(13) cylinder head nuts/washers
(14) cylinder head

20. Remove the dowel pins (15), cylinder head gasket (16) and cam chain guide (17).

NOTICE

Do not let the dowel pins and cam chain fall into the crankcase.

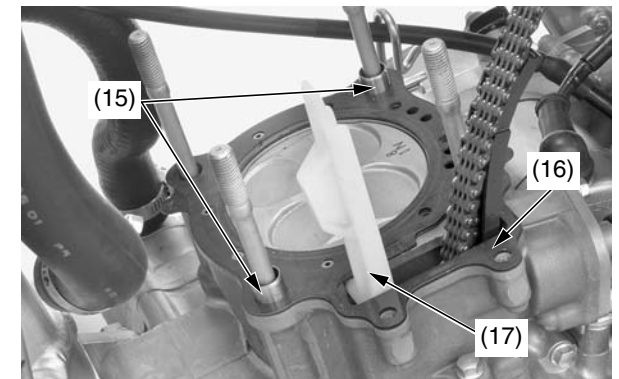

(15) dowel pins
(16) cylinder head gasket
(17) cam chain guide

Piston/Piston Rings/Piston Pin

Cylinder Removal

1. Remove the cylinder bolt (1) and cylinder (2).

NOTICE

*Do not let the cam chain fall into the crankcase.
Do not pry on or strike the cylinder.*

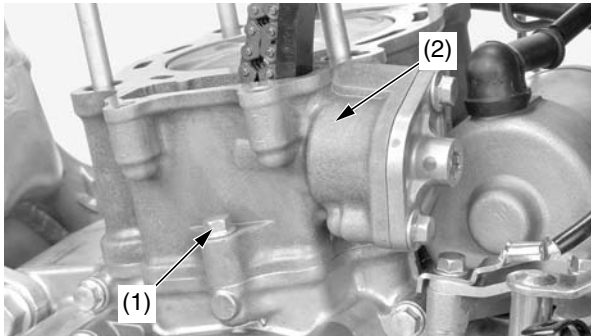

- (1) cylinder bolt
- (2) cylinder

2. Remove the dowel pins (3) and cylinder gasket (4).

NOTICE

Do not let the dowel pins fall into the crankcase.

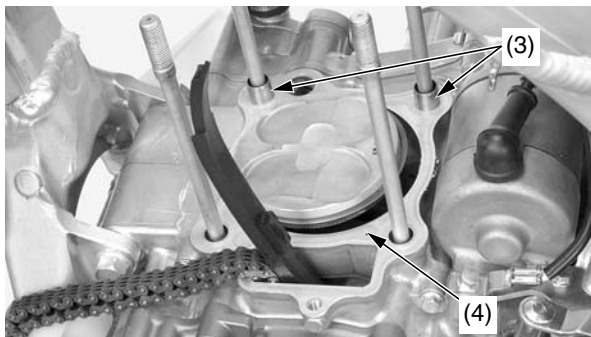

- (3) dowel pins
- (4) cylinder gasket

Piston Removal

1. Place clean shop towels in the crankcase to keep the piston pin clips, or other parts, from falling into the crankcase.
2. Remove the piston pin clips (1) using a pair of needle-nose pliers.
3. Press the piston pin (2) out of the piston (3), and remove the piston.

Under racing conditions, the piston and rings should be replaced after 15.0 hours of running. Replace the piston pin after 15.0 hours of running.

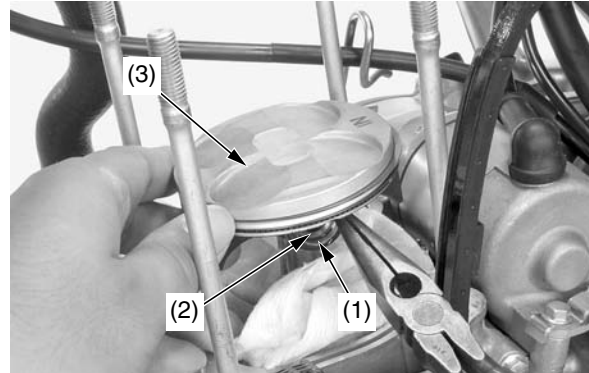

- (1) piston pin clip
- (2) piston pin
- (3) piston

4. Spread each piston ring (4) and remove by lifting it up at a point just opposite the gap.

NOTICE

Do not damage the piston ring by spreading the ends too far.

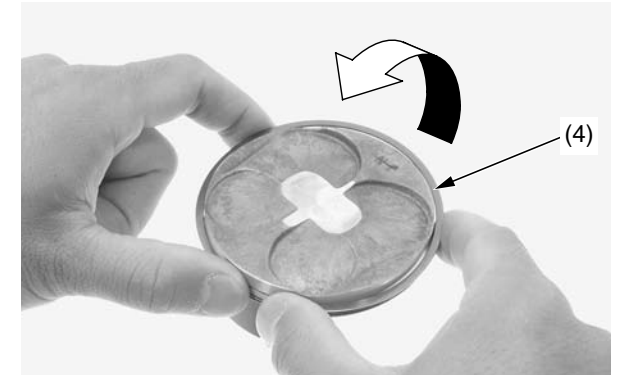

- (4) piston ring

Piston/Piston Pin/Piston Ring Inspection

We recommend you consult the Service Manual or your authorized Honda dealer for correct Service Limit measurements.

Piston Ring Installation

1. Remove the carbon deposits from the piston crown and piston ring grooves with the removed ring.
2. Apply engine oil to the piston rings and install them.

NOTICE

Do not damage the piston ring by spreading the ends too far.

Do not damage the piston during piston ring installation.

- To install the oil ring, install the spacer first, then install the side rails.
 - Install the top ring on the piston with the marking side facing up.
3. After installing the rings they should rotate freely, without sticking.
Space the ring end gaps 180 degrees apart between top ring and upper side rail.
Space the ring end gaps 90 degrees apart between upper side rail, spacer and lower side rail.

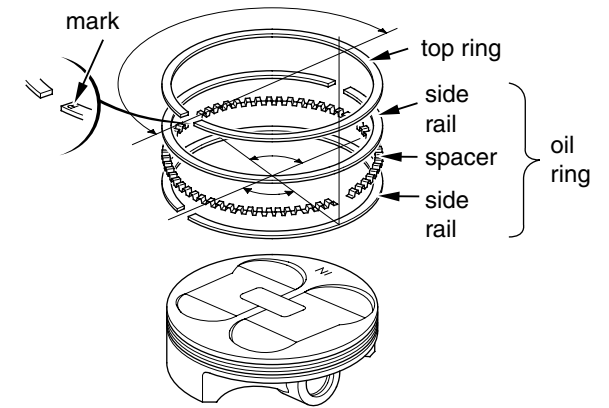
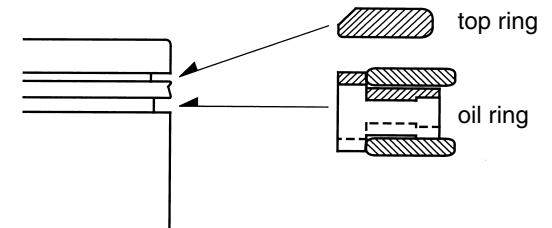

Piston/Piston Rings/Piston Pin

Piston Installation

1. Place clean shop towels over the crankcase opening to keep the piston pin clips from falling into the crankcase.
2. Apply molybdenum disulfide oil solution (a mixture of 1/2 engine oil and 1/2 molybdenum disulfide grease containing more than 3% molybdenum disulfide additive) to the connecting rod small end.
3. Install the piston (1) with the "IN" mark (2) and/or the large valve recesses (3) facing the intake side of the engine.
4. Apply clean engine oil to the piston pin (4). Install the piston pin and new piston pin clips (5).

NOTICE

Use new piston pin clips. Never reuse old piston pin clips.
Do not let the piston pin clips fall into the crankcase.
Do not align the piston pin clip end gap with the piston cut-out (6).

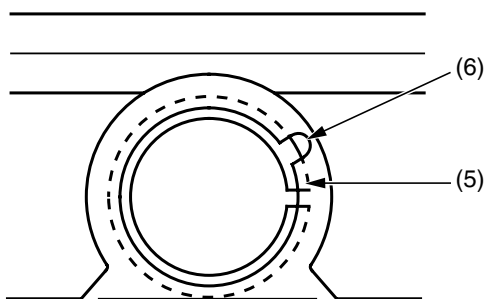
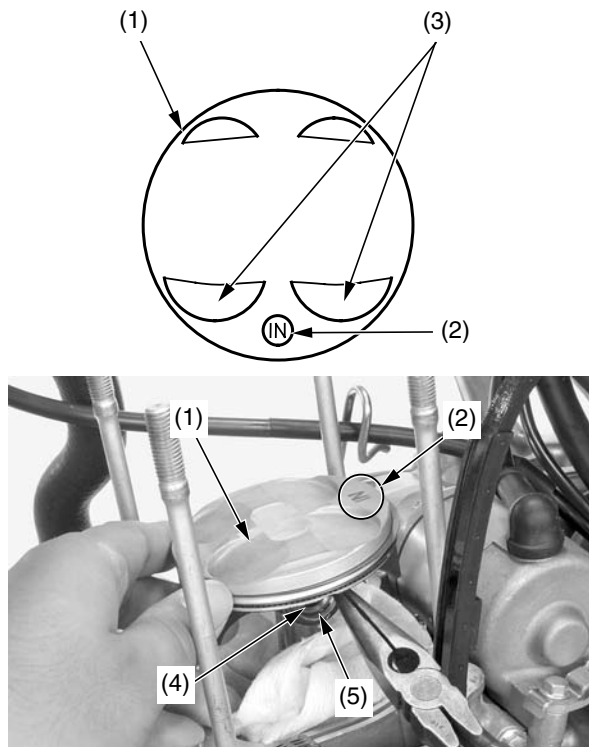

- | | |
|--------------------------|---------------------|
| (1) piston | (4) piston pin |
| (2) "IN" mark | (5) piston pin clip |
| (3) large valve recesses | (6) piston cut-out |

Cylinder Installation

1. Place clean shop towels over the crankcase opening to prevent dust or dirt from entering the engine.
2. Clean off any gasket material from the gasket surface of the crankcase.
3. Remove the shop towel.
Do not let any gasket debris fall into the crankcase.
4. Install the dowel pins (1) and new cylinder gasket (2).

NOTICE

Do not let the dowel pins fall into the crankcase.



- (1) dowel pins
(2) cylinder gasket

5. Clean the any gasket material off the cylinder.

6. Apply clean engine oil to the cylinder wall, piston outer surface and piston rings. Route the cam chain (3) through the cylinder (4). Install the cylinder over the piston rings by hand while compressing the piston rings (5).

NOTICE

Do not damage the piston rings and cylinder walls.

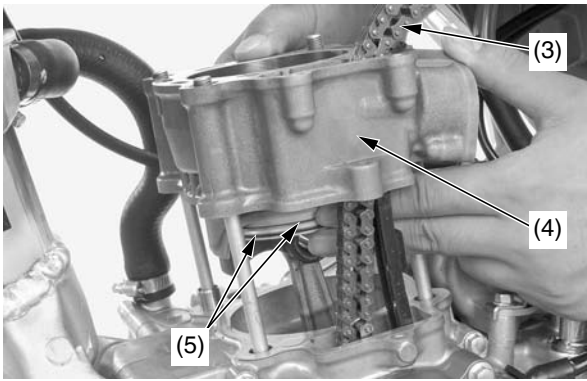

(3) cam chain
(4) cylinder

(5) piston rings

7. Install the cam chain guide (6) and fit the cam chain guide tabs (7) in the cylinder cut-outs (8). Push the guide until it bottoms in the crankcase guide hole.

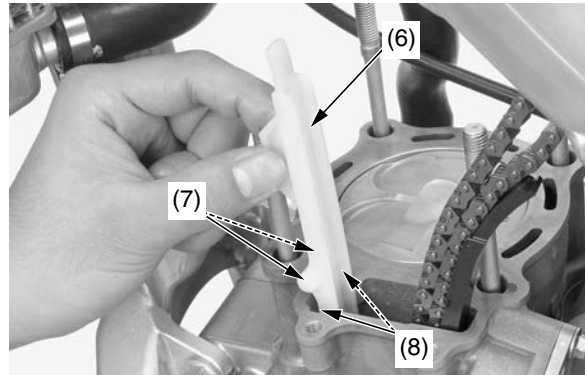

(6) cam chain guide
(7) cam chain guide tabs
(8) cylinder cut-outs

Cylinder Head Installation

1. Install the dowel pins (1) and new cylinder head gasket (2).

NOTICE

Do not let the dowel pins fall into the crankcase.



(1) dowel pins
(2) cylinder head gasket

(cont'd)

Piston/Piston Rings/Piston Pin

- Route the cam chain through the cylinder head (3).
Install the cylinder head.

NOTICE

Do not damage mating surfaces when installing the cylinder head.

- Apply engine oil to all cylinder head nut threads.
Install the washers and cylinder head nuts (4).
Tighten the cylinder head nuts to the specified torque:
29 lbf·ft (39 N·m, 4.0 kgf·m)

NOTICE

Do not let the washers and nuts fall into the crankcase.

Tighten the cylinder head nuts in a criss-cross pattern in two or three steps.

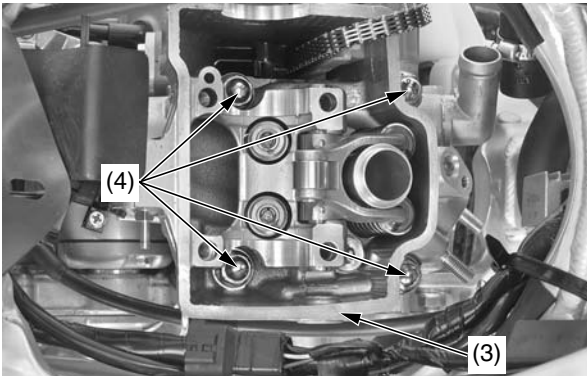

(3) cylinder head
(4) cylinder head nuts/washers

- Install the cylinder bolt (5), cylinder head bolts (6) and tighten them to the specified torque:
7 lbf·ft (10 N·m, 1.0 kgf·m)

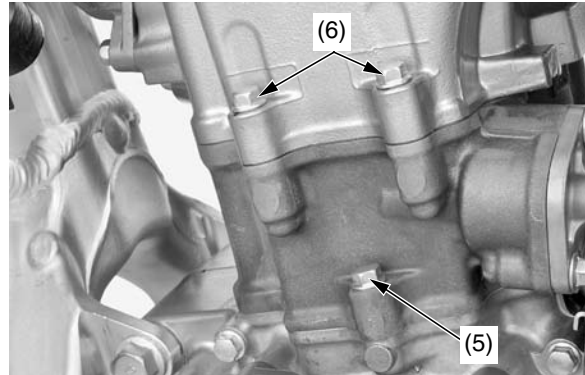

(5) cylinder bolt
(6) cylinder head bolts

- Install the engine hanger plates (7), engine hanger nuts/bolts (8) of the frame side and engine hanger nut/bolt (9) of the engine side.
Tighten the engine hanger nut to the specified torque:
frame side: 25 lbf·ft (34 N·m, 3.5 kgf·m)
engine side: 40 lbf·ft (54 N·m, 5.5 kgf·m)

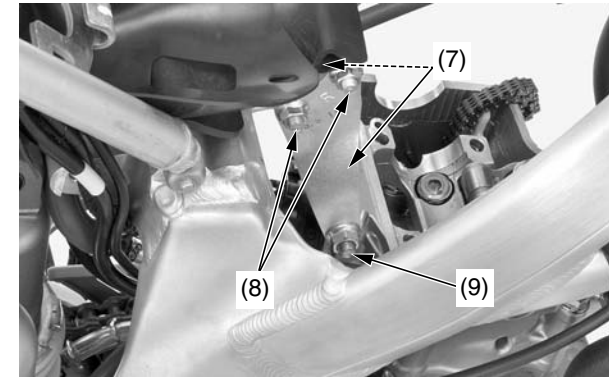

(7) engine hanger plate
(8) engine hanger nuts/bolts of the frame side
(9) engine hanger nut/bolt of the engine side

6. Connect the radiator hose (10) to the cylinder head and tighten the radiator hose clamp (11) securely.

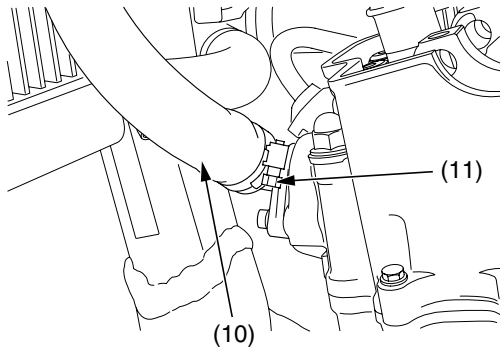

(10) radiator hose
(11) radiator hose clamp

7. Install the shims and camshaft (page 71).
8. Install the spark plug (page 61).

9. Install the cylinder head cover (page 73).
Connect the direct ignition coil (12).

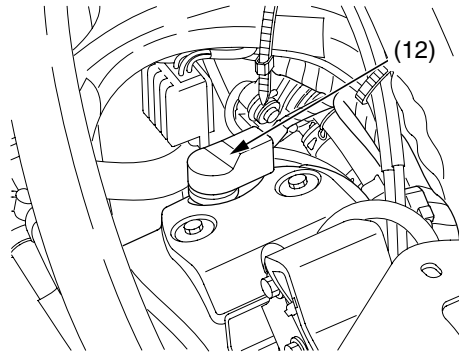

(12) direct ignition coil

10. Install the PAIR control valve (13), PAIR control valve bolts/nuts (14) and air supply pipe bolt (15).
11. Tighten the PAIR control valve nuts and air supply pipe bolt to the specified torque:
7 lbf·ft (10 N·m, 1.0 kgf·m)
12. Connect the vacuum (16) and air suction (17) hoses.

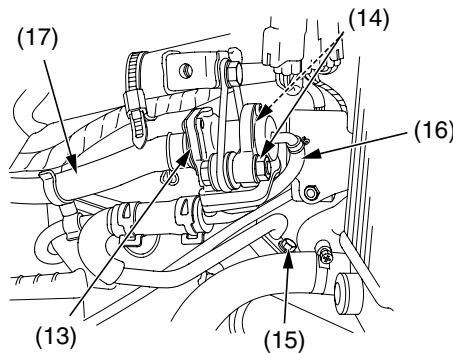

(13) PAIR control valve
(14) PAIR control valve bolts/nuts
(15) air supply pipe bolt
(16) vacuum hose
(17) air suction hose

13. Install the exhaust pipe (page 64).
14. Install the carburetor (page 133).
15. Install the subframe and muffler (pages 40,63).
16. Install the fuel tank and the seat (pages 36, 38).
17. Fill the cooling system with the recommended radiator coolant (page 48).

Suspension

Refer to *Safety Precautions* on page 25.

Loose, worn, or damaged suspension components may adversely affect the handling and stability of your motorcycle. If any suspension components appear worn or damaged, see your Honda dealer for further inspection. Your dealer is qualified to determine whether or not replacement parts or repairs are needed.

Front Suspension Inspection

- When your CRF is new, break it in for approximately one hour to ensure that the suspension has worked in (page 21).
- After break-in, test run your CRF with the front suspension at the standard setting before attempting any adjustments.
- For optimum fork performance, we recommend that you disassemble and clean the fork after riding your CRF for 3 hours. See page 107 for fork disassembly.
- Replace the fork oil every 7.5 hours of running. See page 84 for oil level adjustment after changing the fork oil.
- Replace the damper oil every 22.5 hours of running. See page 111 for oil level adjustment after changing the damper oil.
- Use Pro Honda HP Fork Oil 5W or an equivalent which contains special additives to assure maximum performance of your CRF's front suspension.
- Periodically check and clean all front suspension parts to assure top performance. Check the dust seals for dust, dirt, and foreign materials. Check the oil for any contamination.

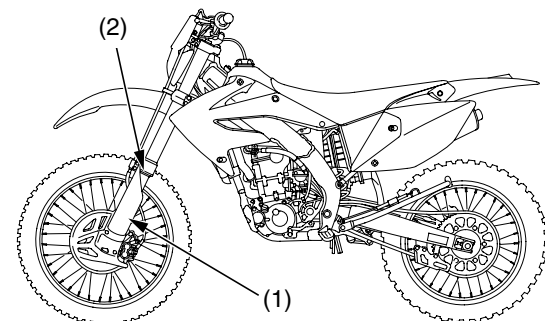

(1) fork protector (2) dust seal

- Refer to *Suspension Adjustment Guidelines* (page 125). Make all rebound and compression damping adjustments in one-click increments. (Adjusting two or more clicks at a time may cause you to pass over the best adjustment.) Test ride after each adjustment.
- If you become confused about adjustment settings, return to the standard position and start over.
- If the fork is still too stiff/soft after adjusting compression damping, determine which portion of the travel is still too stiff/soft. This is an important step that will help you solve suspension problems.

1. Make sure that the fork protectors (1) and dust seals (2) are clean and not packed with mud and dirt.
2. Check for signs of oil leakage. Damaged or leaking fork seals should be replaced before your CRF is ridden.

3. Inspect the wear rings (3) for wear or damage. Replace the wear ring if it is 0.06 in (1.5 mm) or flat with the outer tube (4). When replacing the wear ring, remove the fork leg (page 107). Install the wear ring with its end gap facing rearward.

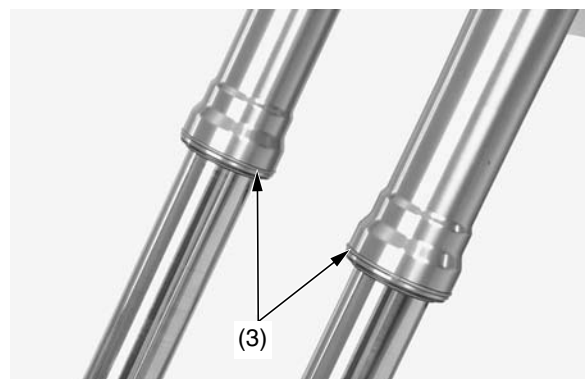
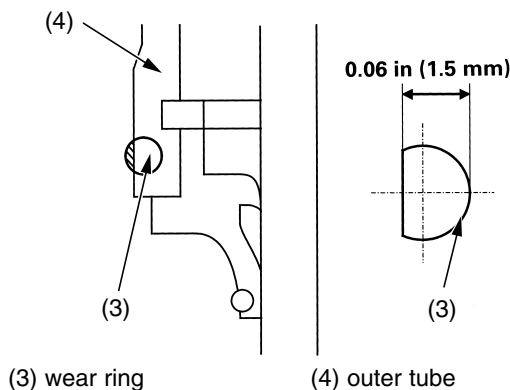

(3) wear rings

4. Make a quick check of fork operation by locking the front brake and pushing down on the handlebar several times.

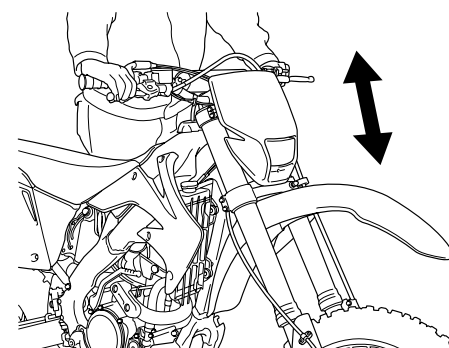

Rear Suspension Inspection

The swingarm is controlled by one hydraulic shock absorber with an aluminum reservoir for oil and nitrogen gas pressure. The gas pressure in the reservoir is contained within a rubber bladder.

The shock absorber's spring pre-load and damping adjustments (compression and rebound) should be adjusted for the rider's weight and track conditions (page 124).

Do not attempt to disassemble, service, or dispose of the damper; see your Honda dealer. The instructions found in this owner's manual are limited to adjustments of the shock assembly only.

- When your CRF is new, break it in for approximately one hour with the standard suspension settings before attempting to adjust the rear suspension.
- Make all compression and rebound damping adjustments in the specified increment or turns described in pages 121. (Adjusting two or more increments or turns at a time may cause you to pass over the best adjustment.) Test ride after each adjustment.
- If the rear suspension is too stiff/soft, adjust it by turning all the compression and rebound adjusters according to the procedures described in page 121. After adjusting the adjusters simultaneously, suspension may be fine-tuned by turning one of the compression and rebound damping adjusters in one click or in 1/12 turn increments.
- If you have a problem finding an acceptable adjustment, return to the standard position and begin again.

1. Bounce the rear of the motorcycle up and down and check for smooth suspension action.



2. Lift the subframe to the upright position (page 39).
3. Check for a broken or collapsed spring.
4. Check the rear shock absorber (1) for a bent rod or oil leaks.

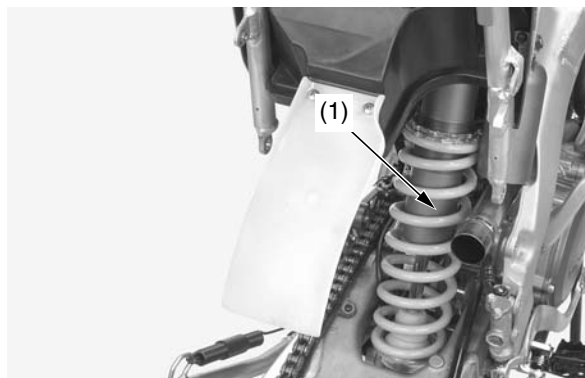

(1) rear shock absorber

5. Push the rear wheel sideways to check for worn or loose swingarm bearings. There should be no movement. If there is, have the bearings replaced by your Honda dealer.

Suspension

Recommended Fork Oil

viscosity (weight)	5 W
suggested oil	Pro Honda HP Fork Oil or equivalent

Fork Oil Change

Refer to *Front Suspension Disassembly* on page 107.

1. Record the rebound damping adjuster position and turn the adjuster counterclockwise until it stops.
2. Hold the outer tube (1), then remove the fork damper (2) from the outer tube using the lock nut wrench (3). Gently slide the outer tube down onto the lower end of the slider (4).

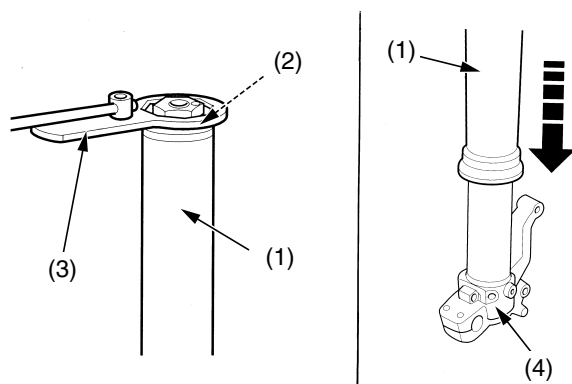

(1) outer tube
(2) fork damper
(3) lock nut wrench
(4) slider, lower end

NOTICE

The outer tube (1) can drop on the slider (7) and damage the fork dust seal (5) and guide bushing (6) when the fork damper is removed. To avoid damage hold both the outer tube and slider when removing the fork damper.

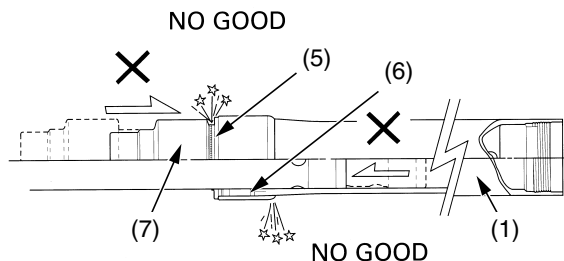

(1) outer tube
(5) dust seal
(6) guide bushing
(7) slider

3. Drain the fork oil from the outer tube (1). Drain the fork oil from the oil hole (9) of the fork damper.

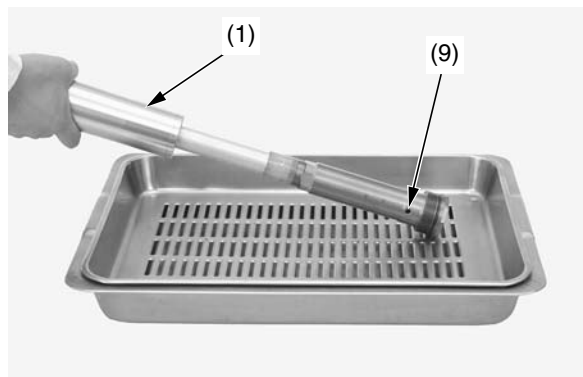

(1) outer tube
(9) oil hole

4. Drain the fork oil by turning the outer tube (1) upside down. (About 12 cc of fork oil will be left in the outer tube when it is left inverted for about 20 minutes at 20 °C/68°F.)

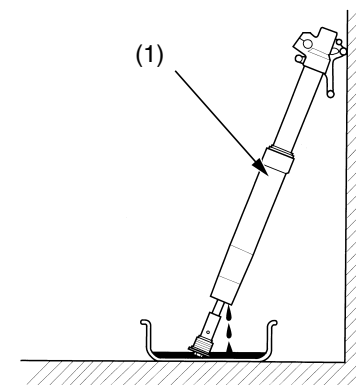

(1) outer tube

Amount of fork oil left in the fork (within damper and spring)

unit: cc

minute	5	10	20	35	55	85	145
30/86	27	15.3	10.6	9.4	8.3	7.9	7.9
20/68	29.4	16.5	11.8	10.6	9.4	8.2	8.2
10/50	28.2	21.2	16.5	15.3	12.9	11.8	11.8
0/32	30.6	22.4	18.8	16.5	16.5	15.3	14.1

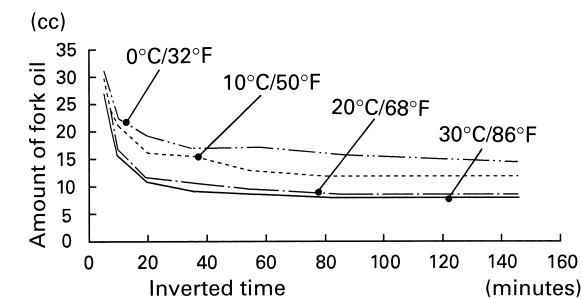

5. Pour the recommended fork oil (page 84) into the outer tube.

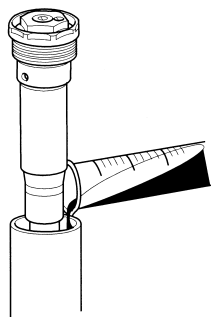

Fork Oil Capacity:

Standard (0.42 kgf/mm) Fork Spring

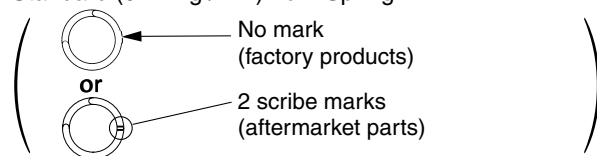

Standard oil capacity	11.8 US oz (348 cm ³)	
Maximum oil capacity	13.5 US oz (399 cm ³)	Slightly stiffer as it nears full compression.
Minimum oil capacity	10.2 US oz (303 cm ³)	Slightly softer as it nears full compression.

Optional Softer (0.40 kgf/mm) Fork Spring

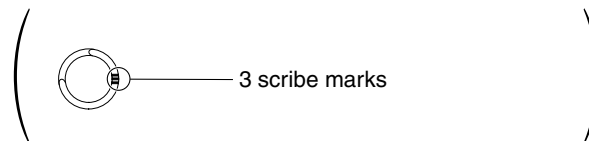

Standard oil capacity	11.9 US oz (353 cm ³)	
Maximum oil capacity	13.7 US oz (404 cm ³)	Slightly stiffer as it nears full compression.
Minimum oil capacity	10.4 US oz (308 cm ³)	Slightly softer as it nears full compression.

Optional Stiffer (0.44 kgf/mm) Fork Spring

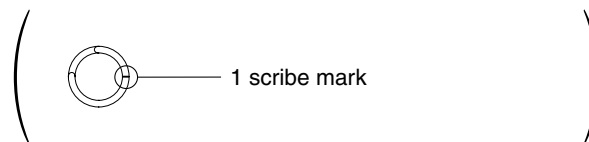

Standard oil capacity	11.9 US oz (351 cm ³)	
Maximum oil capacity	13.6 US oz (402 cm ³)	Slightly stiffer as it nears full compression.
Minimum oil capacity	10.3 US oz (306 cm ³)	Slightly softer as it nears full compression.

Be sure the oil capacity is the same in both fork legs.

6. Check that the O-ring (10) on the fork damper (2) is in good condition. Apply the recommended fork oil to the O-ring.

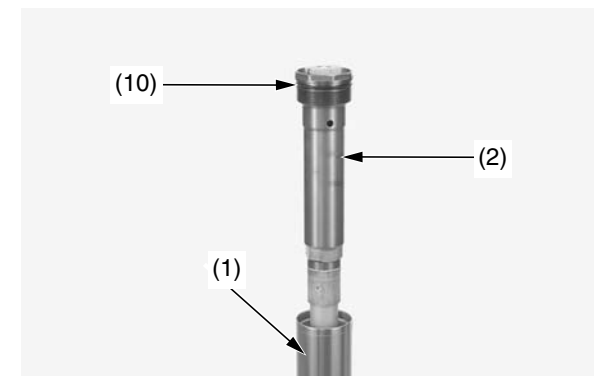

(1) outer tube
(2) fork damper
(10) O-ring

7. Temporarily install the fork damper (2) to the outer tube (1). After installing the fork leg (page 117) tighten the fork damper to the specified torque:
Actual:
25 lbf·ft (34 N·m, 3.5 kgf·m)
Torque wrench scale reading:
23 lbf·ft (31 N·m, 3.2 kgf·m)

Brakes

Refer to *Safety Precautions* on page 25.

Both the front and rear brakes are the hydraulic disc type. As the brake pads wear, the brake fluid level will drop. A leak in the system will also cause the level to drop.

Frequently inspect the system to ensure there are no fluid leaks. Periodically inspect the brake fluid level and the brake pads for wear.

If the front brake lever or rear brake pedal freeplay does not feel within the normal range while riding, check the brake pads. If they are not worn beyond the recommended limit (page 89), there is probably air in the brake system. Refer to the Honda Service Manual or see your Honda dealer to have the air bled from the system.

Front Brake Lever Adjustment

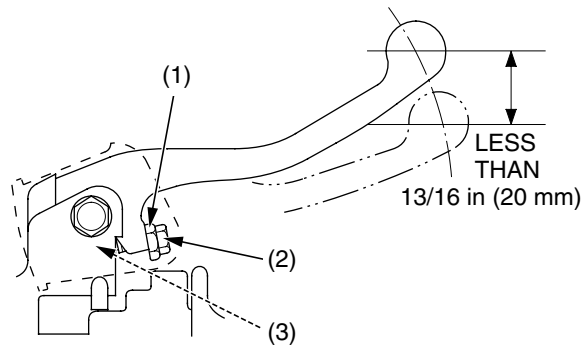

(1) lock nut
(2) adjuster
(3) piston

1. Loosen the lock nut (1).
2. To position the front brake lever farther away from the handgrip, turn the adjuster (2) clockwise.
To position the front brake lever closer to the handgrip, turn the adjuster counterclockwise.
3. While holding the adjuster, tighten the lock nut to the specified torque:
4.4 lbf·ft (5.9 N·m, 0.6 kgf·m)
4. Apply the brake, release it, then spin the wheel and check that it rotates freely. Repeat this procedure several times.
5. Check freeplay by pulling in slowly on the front brake lever until the brake starts to engage.
Freeplay: **LESS THAN 13/16 in (20 mm)**
6. Apply grease to the contacting faces of the adjuster and piston (3).

Rear Brake Pedal Height

The rear brake pedal height should be approximately level with the right footpeg.

1. Loosen the lock nut (1) and turn the adjusting bolt (2) in direction (+) to raise the rear brake pedal (3) or in direction (–) to lower it.
2. Tighten the lock nut to the specified torque at the desired pedal height:
4.4 lbf·ft (5.9 N·m, 0.6 kgf·m)

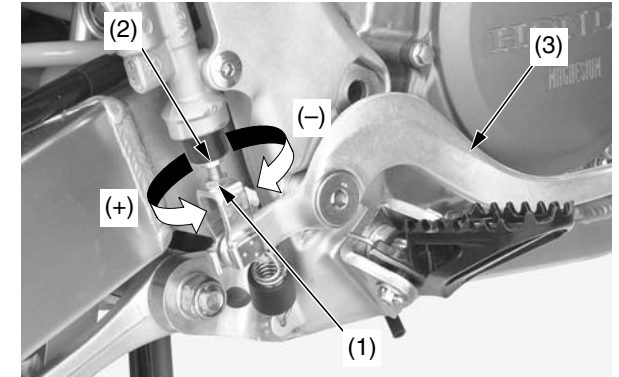

(1) lock nut
(2) adjusting bolt
(3) rear brake pedal
(+) raise the pedal height
(–) lower the pedal height

Fluid Level Inspection

Front Brake Fluid Level Check

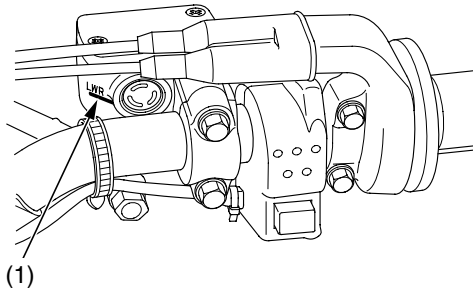

(1) LWR (LOWER) level mark

With the motorcycle in an upright position, check the fluid level.

It should be above the LWR (LOWER) level mark (1). If the level is at or below the LWR (LOWER) level mark, check the brake pads for wear (page 89).

Worn brake pads should be replaced. If the pads are not worn, have your brake system inspected for leaks.

If the front brake lever freeplay exceeds 0.8 in (20 mm), there is probably air in the brake system and it must be bled. Refer to the Honda Service Manual or see your Honda motorcycle dealer for brake bleeding.

Rear Brake Fluid Level Check

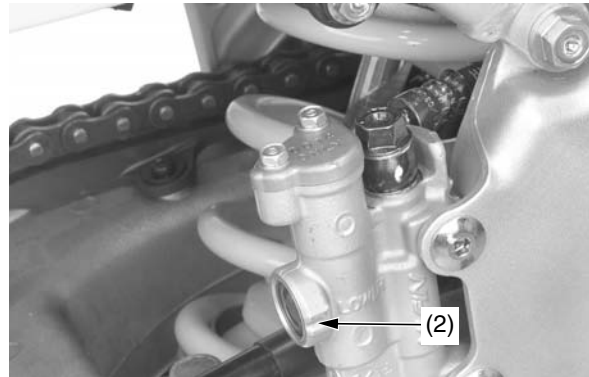

(2) LOWER level mark

With the motorcycle in an upright position, check the fluid level.

It should be above the LOWER level mark (2). If the level is at or below the LOWER level mark, check the brake pads for wear (page 89).

Worn brake pads should be replaced. If the pads are not worn, have your brake system inspected for leaks.

If the rear brake pedal freeplay exceeds 0.8 in (20 mm), there is probably air in the brake system and it must be bled. Refer to the Honda Service Manual or see your Honda motorcycle dealer for brake bleeding.

Brakes

Adding Front Brake Fluid

NOTICE

Spilled brake fluid will severely damage instrument lenses and painted surfaces. It is also harmful to some rubber parts. Be careful whenever you remove the reservoir cap: make sure the reservoir is horizontal first.

- Always use fresh DOT4 brake fluid from a sealed container when servicing the system. Do not mix different types of fluid, they may not be compatible.
- The recommended brake fluid is Pro Honda DOT 4 brake fluid or an equivalent.

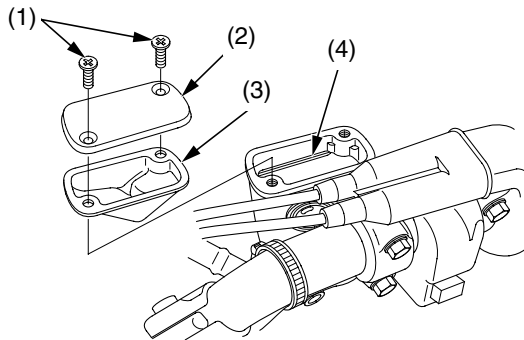

- (1) screws (4) upper level mark
(2) reservoir cap
(3) diaphragm

1. Remove the screws (1), reservoir cap (2) and diaphragm (3).
2. Fill the reservoir with DOT 4 brake fluid to the upper level mark (4). Do not overfill.
3. Reinstall the diaphragm and reservoir cap.
4. Tighten the screws to the specified torque: 0.7 lbf·ft (1.0 N·m, 0.1 kgf·m)

Adding Rear Brake Fluid

NOTICE

Spilled brake fluid will severely damage instrument lenses and painted surfaces. It is also harmful to some rubber parts. Be careful whenever you remove the reservoir cap: make sure the reservoir is horizontal first.

- Always use fresh DOT4 brake fluid from a sealed container when servicing the system. Do not mix different types of fluid, they may not be compatible.
- The recommended brake fluid is Pro Honda DOT 4 brake fluid or an equivalent.

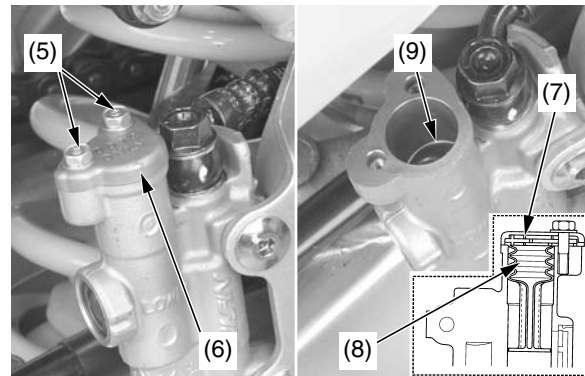

- (5) bolts (8) diaphragm
(6) reservoir cap (9) upper level mark
(7) set plate

1. Remove the bolts (5) reservoir cap (6), set plate (7) and diaphragm (8).
2. Fill the reservoir with DOT 4 brake fluid to the upper level mark (9). Do not overfill.
3. Reinstall the diaphragm, set plate and reservoir cap.
4. Tighten the bolts to the specified torque: 0.7 lbf·ft (1.0 N·m, 0.1 kgf·m)

Other Inspection

- Make sure there are not fluid leaks.
- Check for deterioration or cracks in the hoses and fittings.

Brake Pad Wear

Brake pad wear depends on the severity of usage and track conditions. (Generally, the pads will wear faster on wet and dirty tracks) Inspect the pads at each regular maintenance interval (pages 27 and 28).

Front Brake Pads

Inspect the brake pads (1) through the front wheel to determine the pad wear. If either pad is worn anywhere to a thickness of 0.04 in (1 mm), both pads must be replaced.

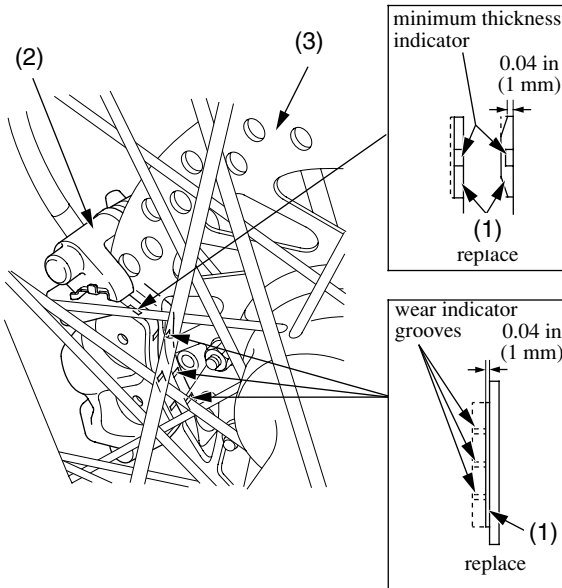

(1) brake pads
(2) front brake caliper

(3) brake disc

Rear Brake Pads

Inspect the brake pads (4) from the rear side of the caliper to determine the pad wear. If either pad is worn anywhere to a thickness of 0.04 in (1 mm), both pads must be replaced.

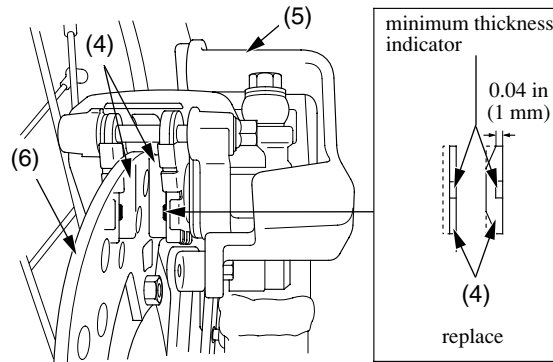

(4) brake pads
(5) rear brake caliper

(6) brake disc

Other Inspections

Check that the front brake lever and rear brake pedal assemblies are positioned properly and the securing bolts are tight.

Make sure there are no fluid leaks. Check for deterioration or cracks in the hoses and fittings.

Wheels

Refer to *Safety Precautions* on page 25.

Maintenance of spoke tension and wheel trueness (roundness) is critical to safe motorcycle operation. During the first few rides, spokes will loosen more rapidly due to the initial seating of the parts. Excessively loose spokes may result in instability at high speeds and the possible loss of control. It's also important that the rim locks are secure to prevent tire slippage.

It is not necessary to remove the wheels to perform the recommended service in the Maintenance Schedule (pages 27 and 28). However, information for wheel removal is provided for emergency situations.

Wheel Rims & Spokes

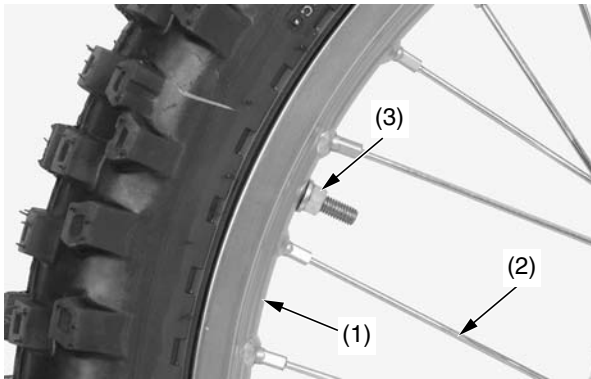

- (1) wheel rims
- (2) spokes
- (3) rim lock

1. Inspect the wheel rims (1) and spokes (2) for damage.

2. Tighten, any loose spokes and rim locks (3) to the specified torque:
Spoke : 2.7 lbf·ft (3.68 N·m, 0.4 kgf·m)
Rim Lock : 9 lbf·ft (12 N·m, 1.2 kgf·m)
3. Check wheel rim runout. If runout is noticeable, see the Honda Service Manual for inspection instructions.

Axles & Wheel Bearings

See the Honda Service Manual for inspection information:

1. Check the axle shaft for runout.
2. Check the condition of the wheel bearings.

Refer to *Safety Precautions* on page 25.

To safely operate your CRF, the tires must be the proper type (off-road) and size, in good condition with adequate tread, and correctly inflated.

⚠ WARNING

Using tires that are excessively worn or improperly inflated can cause a crash in which you can be seriously hurt or killed.

Follow all instructions in this owner's manual regarding tire inflation and maintenance.

The following pages give detailed information on how and when to check your air pressure, how to inspect your tires for wear and damage, and our recommendations on tire replacement.

Air Pressure

Properly inflated tires provide the best combination of handling, tread life, and riding comfort. Generally, underinflated tires wear unevenly, adversely affect handling, and are more likely to fail from being overheated. Underinflated tires can also cause wheel damage on hard terrain. Overinflated tires make your CRF ride harshly, are more prone to damage from surface hazards, and wear unevenly.

Make sure the valve stem caps are secure. If necessary, install a new cap.

Always check air pressure when your tires are “cold.” If you check air pressure when your tires are “warm” — even if your CRF has only been ridden for a few miles — the readings will be higher. If you let air out of warm tires to match the recommended cold pressures, the tires will be underinflated.

The correct “cold” tire pressures are:

Front	15 psi (100 kPa, 1.0 kgf/cm ²)
Rear	15 psi (100 kPa, 1.0 kgf/cm ²)

If you decide to adjust tire pressures for a particular riding condition, make changes a little at a time.

Inspection

Take time to inspect your tires and wheels before you ride.

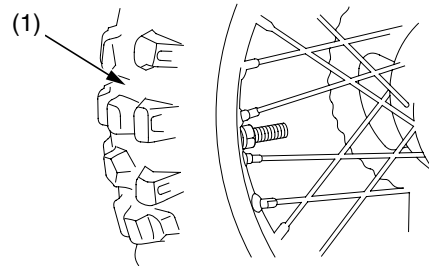

(1) tire tread depth

- Inspect carefully for bumps or bulges in the side of the tire or the tread. Replace any tire that has a bump or bulge.
- Look closely for cuts, slits, or cracks in the tires. Replace a tire if you can see fabric or cord.
- Check for rocks or other objects embedded in the tire or tread. Remove any objects.
- Measure tread depth (1). Replace the tire before depth at the center reaches 0.12 in (3 mm), or any time you notice a reduction in traction.
- Check the position of both valve stems. A tilted valve stem indicates the tube is slipping inside the tire or the tire is slipping on the rim.

Tube Replacement

If a tube is punctured or damaged, you should replace it as soon as possible. A repaired tube may not have the same reliability as a new one, and it may fail while you are riding.

Use a replacement tube equivalent to the original.

Tires & Tubes

Tire Replacement

The tires that came on your CRF were designed to provide a good combination of handling, braking, durability, and comfort across a broad range of riding conditions.

⚠ WARNING

Installing improper tires on your motorcycle can affect handling and stability. This can cause a crash in which you can be seriously hurt or killed.

Always use the size and type of tires recommended in this owner's manual.

Front	80/100 – 21 51M	
	DUNLOP	D742F
Rear	100/100 – 18 59M	
	DUNLOP	D756
Type	bias-ply, tube	

- Use a replacement tire equivalent to the original.
- Replace the tube any time you replace a tire. The old tube will probably be stretched and, if installed in a new tire, could fail.

Refer to *Safety Precautions* on page 25.

1. Check the side stand spring (1) for damage and loss of tension.
2. Check the side stand assembly for freedom of movement.

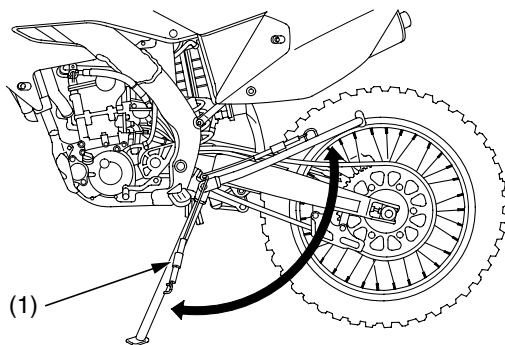

(1) side stand spring

If the side stand is stiff or squeaky, clean the pivot area and lubricate the pivot bolt with grease.

Drive Chain

Refer to *Safety Precautions* on page 25.

An endless (riveted master link) chain connects the drive and driven sprockets. The O-ring chain uses rubber between the side plates of the pin and roller links to seal in the manufacturer-installed lubricating grease and keep out moisture and dirt.

The service life of the chain depends on proper lubrication and adjustment. Poor maintenance can cause premature wear or damage to the drive chain or sprockets.

Under severe usage, or when the motorcycle is ridden in unusually dusty or muddy areas, more frequent maintenance will be necessary.

Before servicing your drive chain, turn the engine OFF, raise the rear wheel off the ground by placing an optional workstand or equivalent support under the engine and check that your transmission is in neutral.

It is not necessary to remove or replace the drive chain to perform the recommended service in the Regular off-road Use Maintenance Schedule (page 27).

Drive Chain Inspection

1. Stop the engine and raise the rear wheel off the ground by placing the optional workstand or equivalent support under the engine and shift the transmission into neutral.
2. Check slack (1) in the upper drive chain run midway between the sprockets (2)(3). Drive chain slack should allow the following vertical movement by hand:
1 – 1 3/8 in (25 – 35 mm)

NOTICE

Excessive chain slack may allow the drive chain to damage the engine cases.

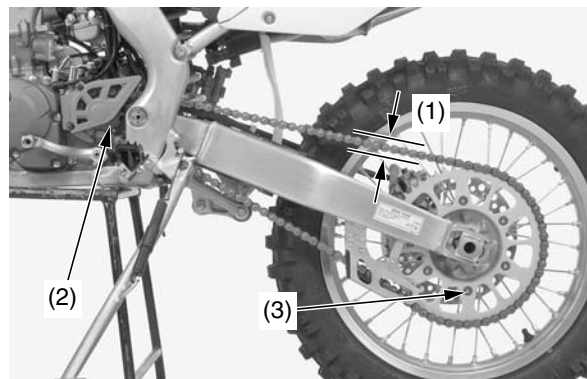

(1) drive chain slack (3) driven sprocket
(2) drive sprocket

If the chain is found to be slack in one segment of its length and taut in another, this indicates that some of the links are either worn, kinked or binding. Kinking and binding can frequently be eliminated by thorough cleaning and lubrication. If the drive chain requires adjustment, procedure is as follows:

Adjustment

1. Loosen the rear axle nut (1).
2. Loosen the lock nuts (2) and turn the adjusting bolts (3) counterclockwise to decrease slack or clockwise to increase slack. Align the index mark (4) of the axle plates (5) with same reference marks (6) on both sides of the swingarm.

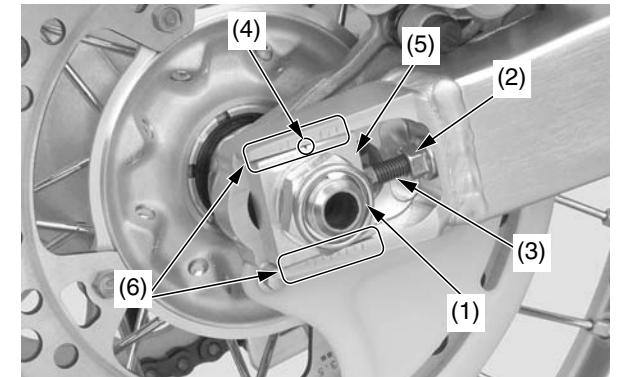

(1) rear axle nut (4) index mark
(2) lock nut (5) axle plate
(3) adjusting bolt (6) reference marks

3. Tighten the rear axle nut to the specified torque:
94 lbf-ft (127 N·m, 13.0 kgf·m)
4. Recheck chain slack and adjust if necessary.
5. Turn the adjusting bolt counterclockwise lightly until it touches the axle plate. Then, tighten the lock nut to the specified torque by holding the adjusting bolt with a wrench.
20 lbf-ft (27 N·m, 2.8 kgf·m)

Removal, Cleaning & Replacement

For maximum service life, the drive chain should be cleaned, lubricated, and adjusted before each outing. Your CRF has an endless (riveted master link) type chain. It should only be removed or replaced by your Honda dealer.

The O-rings can be damaged by steam cleaning, high pressure washers, and certain solvents.

1. Clean the side surfaces of the chain with a dry cloth. Use a high flash point solvent such as kerosene – not gasoline. Do not brush the rubber O-rings. Brushing will damage them. Use of a solvent may also damage the O-rings.
2. Replace the drive chain if it has damaged rollers, loose fitting links, damaged O-rings, or otherwise appears unserviceable.
3. Measure the drive chain plate (1). If the drive chain plate is worn anywhere to a thickness of 0.53 in (13.4 mm), the drive chain must be replaced.

Replacement Chain:

Size/link: DID520MXV/116

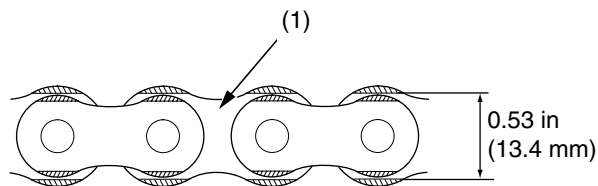

(1) drive chain plate (inner)

4. Inspect the sprocket teeth for possible wear or damage. Replace them if necessary. Never install a new drive chain on badly worn sprockets, or use new sprockets with a badly worn drive chain. Both chain and sprockets must be in good condition, or the new replacement chain or sprocket(s) will wear rapidly. Excessively worn sprocket teeth have a hooked, worn appearance. Replace any sprocket, which is damaged or excessively worn.

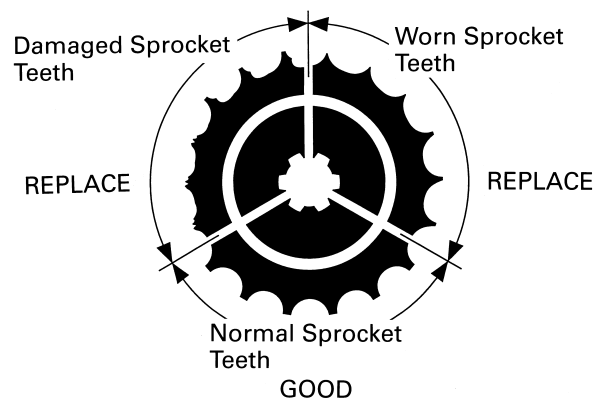

NOTICE

Use of a new chain with worn sprockets will cause rapid chain wear.

5. Lubricate the drive chain.
6. Recheck chain slack and adjust if necessary.

Drive Chain

Drive Chain Sliders

1. Check the chain slider (1) for wear.
If the wear is 3/16 in (5 mm) or more, replace it.

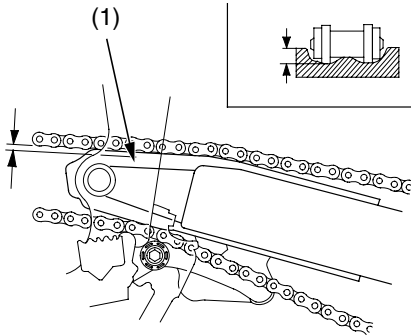

(1) chain slider

2. Check the chain guide slider (2) for wear.
Replace the chain guide slider if it is worn to the bottom of the wear limit groove (3).

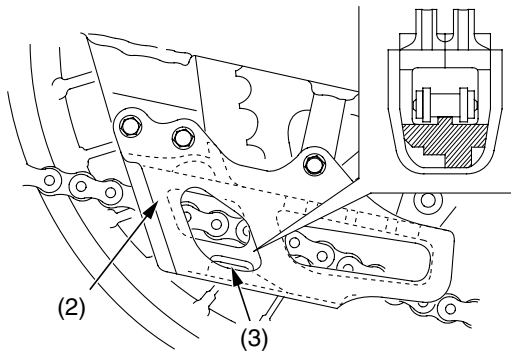

(2) chain guide slider
(3) wear limit groove

Drive Chain Rollers

1. Measure the diameter of the drive chain rollers. Replace them if below the service limit.

Service Limit:

UPPER ROLLER: 1.1 in (29 mm)

LOWER ROLLER: 1.2 in (31 mm)

2. Replace the roller if necessary as follows.
Install the upper drive chain roller (Green) (1) and lower drive chain roller (Black) (2) as shown.

Tighten the drive chain roller bolt and nut to the specified torque.

Upper roller bolt: 9 lbf-ft (12 N·m, 1.2 kgf·m)

Lower roller nut: 9 lbf-ft (12 N·m, 1.2 kgf·m)

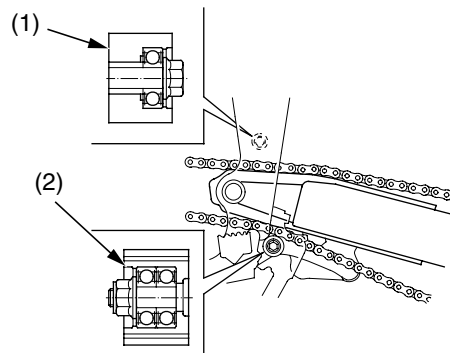

(1) upper drive chain roller (2) lower drive chain roller

Lubrication

Lubricate the drive chain with #80 – 90 gear oil or drive chain lubricant designed specifically for use with O-ring chains. Wipe off the excess oil or chain lubricant.

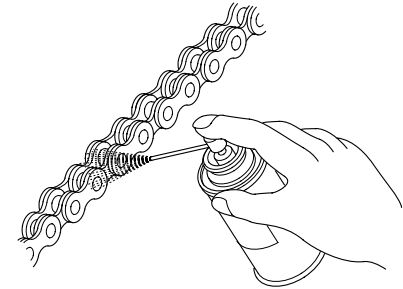

Refer to *Safety Precautions* on page 25.

Steering Head Bearing Inspection

1. With your CRF on a box or optional workstand (front wheel elevated), turn the handlebar to the right and left to check for roughness in the steering head bearings.

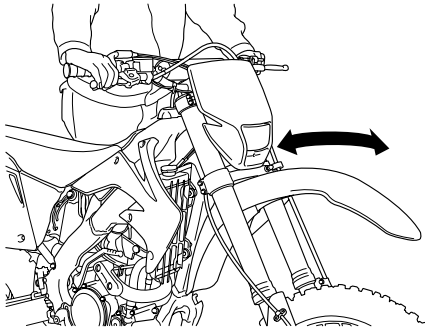

2. Stand in front of your CRF, grab the fork (at the axle), look at the steering head, and push the fork in and out (toward the engine) to check for play in the steering head bearings. If any roughness or play is felt, but you do not see any movement in the steering head, the fork bushings may be worn. Refer to the Honda Service Manual for replacement or adjustment procedures, or see your Honda dealer.



Handlebar Inspection

1. Check the handlebar (1) for bends or cracks.
2. Check that the handlebar has not moved from its proper position (by inspecting the paint mark (2)).
3. Check the torque of the handlebar upper holder bolts (3):
16 lbf·ft (22 N·m, 2.2 kgf·m)
Tighten the front bolts first.

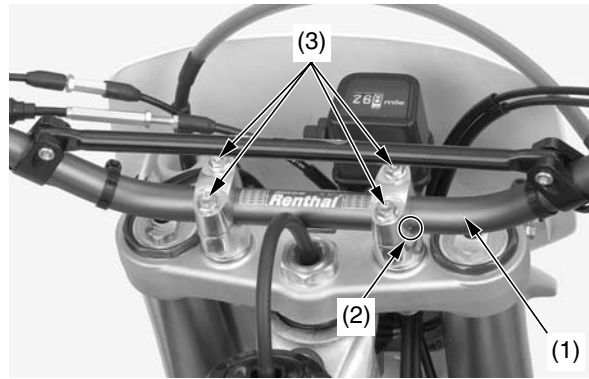

- (1) handlebar
(2) paint mark
(3) handlebar upper holder bolts

Control Cables

Periodically, disconnect the throttle, clutch and hot start cables at their upper ends. Thoroughly lubricate the cable pivot points with a commercially-available cable lubricant. If the clutch lever, hot start lever and throttle operation is not smooth, replace the cable. Be sure the throttle returns freely from fully open to fully closed automatically, in all steering positions.

Additional Maintenance Procedures

Nuts, Bolts, Fasteners

Check and tighten nuts, bolts, and fasteners before every outing.

ENGINE

	Item	Torque		
		lbf•ft	N•m	kgf•m
1	Cylinder head cover bolts	7	10	1.0
2	Exhaust pipe joint nuts	15	21	2.1
3	Coolant drain bolt	7	10	1.0
4	Crankshaft hole cap	11	15	1.5
5	Transmission oil check bolt	9	12	1.2
6	Clutch cover bolts	7	10	1.0
7	Cylinder bolt	7	10	1.0
8	Oil filter cover bolts	9	12	1.2
9	Cylinder head bolts	7	10	1.0
10	Drive sprocket bolt	23	31	3.2
11	Engine oil drain bolt	12	16	1.6
12	Transmission oil drain bolt	12	16	1.6
13	Air supply pipe bolt	7	10	1.0

RIGHT SIDE

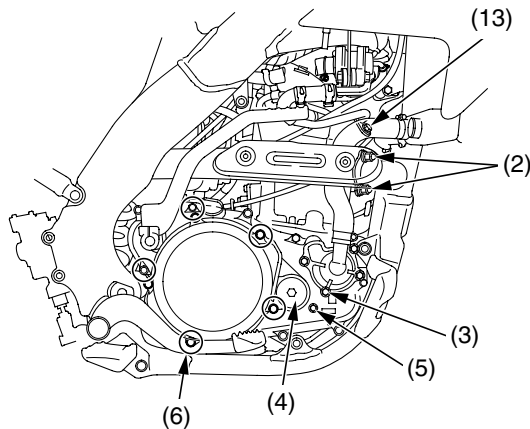

- (2) exhaust pipe joint nuts
- (3) coolant drain bolt
- (4) crankshaft hole cap
- (5) transmission oil check bolt
- (6) clutch cover bolts
- (13) air supply pipe bolt

LEFT SIDE

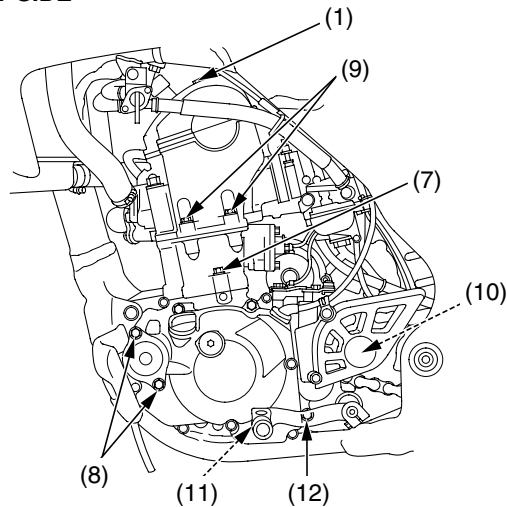

- (1) cylinder head cover bolts
- (7) cylinder bolt
- (8) oil filter cover bolts
- (9) cylinder head bolts
- (10) drive sprocket bolt
- (11) engine oil drain bolt
- (12) transmission oil drain bolt

Refer to *Safety Precautions* on page 25.

Your CRF has a maintenance-free type battery. You do not have to check the battery electrolyte level or add distilled water as you would with a conventional-type battery.

NOTICE

Your battery is a maintenance-free type and can be permanently damaged if the cap strip is removed.

Electrical accessories use current from the battery – even when the engine is stopping. Limited operation also allows the battery to discharge. If you have electrical accessories on your motorcycle – or do not ride frequently, we recommended that you charge the battery frequently (see *Battery Charging on page 100*).

If you do not expect to ride your CRF for at least two weeks, we recommended you remove the battery – or at least disconnect the battery cables (negative cable first).

If you plan to store your CRF, see *Battery Storage* (this page).

If your battery seems weak and/or is leaking electrolyte (cause slow starting or other electrical problems), see your Honda dealer.

WARNING: Battery posts, terminals and related accessories contain lead and lead compounds. **Wash hands after handling.**

Battery Storage

If you plan to store your CRF, we recommend you remove the battery and store it where it can be charged at least every 30 days to maintain its service life.

If you do not remove the battery, we recommend disconnecting the battery cables (negative cable first).

You will get the best storage results from removing the battery and slow (trickle) charging it every 30 days (see *Battery Charging on page 100*).

Before you remove the battery, be sure to read all the information that follows, as well as the information on the battery label.

⚠ WARNING

The battery gives off explosive hydrogen gas during normal operation.

A spark or flame can cause the battery to explode with enough force to kill or seriously hurt you.

Wear protective clothing and a face shield, or have a skilled mechanic do the battery maintenance.

The battery is located under the seat.

Removal

1. Remove the seat (page 36).
2. Remove the battery band (1).
3. Remove the positive terminal cover (2).

4. Disconnect the negative (–) terminal (3) first, then the positive (+) terminal (4) and remove the battery (5).

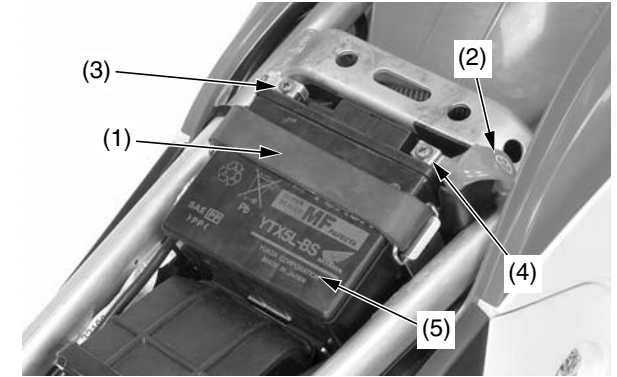

- (1) battery band (4) positive (+) terminal
(2) positive terminal cover (5) battery
(3) negative (–) terminal

5. Unless you have been riding regularly, charge the battery (see page 100).
6. Store your battery in an easy-to-reach location off the floor, in an area protected from freezing temperatures and direct sunlight.
7. Clean the battery box after removing the battery for storage. Dry the battery box.
8. Slow charge the battery (see page 100) once every 30 days.

Installation

1. Reinstall in the reverse order of removal. Be sure to connect the positive (+) terminal first, then the negative (–) terminal.
2. Check all bolts and other fasteners are secure.

Battery

Battery Charging

Be sure to read the information that came with your battery charger and follow the instructions on the battery. Improper charging may damage the battery.

We recommend using a “trickle” charger (1) for home charging. These units can be left connected for long periods without risking damage to the battery. However, do not intentionally leave the charge connected longer than the time period recommended in the charger’s instructions.

Avoid using an automotive-type battery charger. An automotive charger can overheat a motorcycle battery and cause permanent damage.

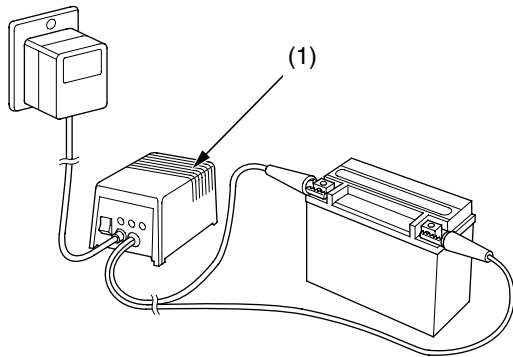

(1) “trickle” charger

Refer to *Safety Precaution* on page 25.

Headlight Bulb

1. Remove the front visor bolts (1) and pull out the front visor (2).

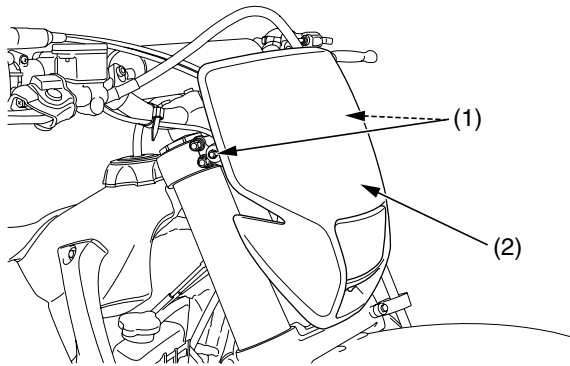

(1) front visor bolts
(2) front visor

2. Disconnect the headlight connector (3). Remove the dust cover (4).

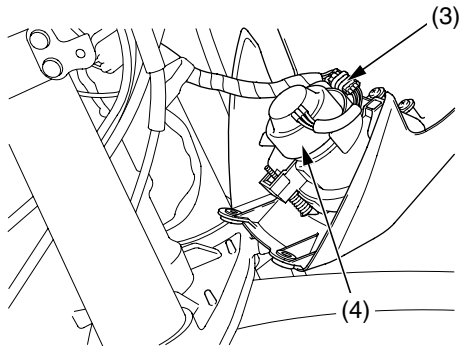

(3) headlight connector
(4) dust cover

3. To pull the headlight bulb out, push and turn the headlight bulb socket (5) counterclockwise.

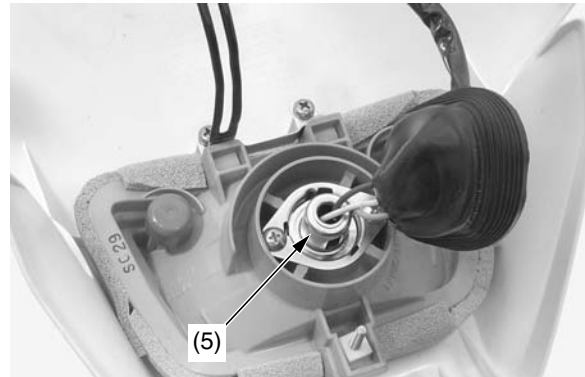

(5) headlight bulb socket

4. To install a new headlight bulb, push and turn the headlight bulb socket clockwise.

If you touch the bulb with your bare hands, clean it with a cloth moistened with denatured alcohol to prevent early bulb failure.

5. Install the dust cover (4) tightly against the headlight unit with its "TOP" mark (6) facing up.

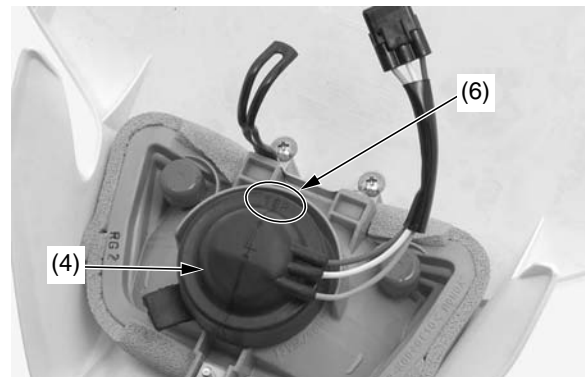

(4) dust cover (6) "TOP" mark

6. To install the headlight, reverse the removal procedure.

Headlight Aim

The headlight aim can be raised or lowered. Turn the adjusting screw (1) clockwise to move the headlight up or turn the adjusting screw counterclockwise to move the headlight down to proper adjustment.

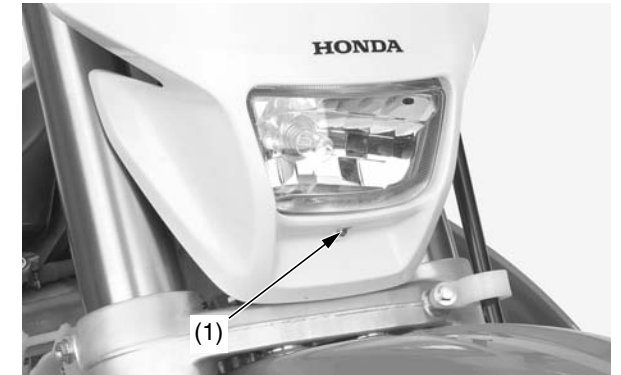

(1) adjusting screw

Taillight

The taillight uses LED illumination. If the taillight does not function properly, see your Honda dealer for service.

This model is equipped with an electric starter and battery for easy engine starting. There is a possibility of damage to the lighting system if the battery is carelessly removed. Never kick-start the engine without the battery connected.

If it becomes necessary to kick-start the engine with the battery removed, remove the relays to the battery to prevent damage to the lighting.

Appearance Care

Refer to *Safety Precautions* on page 25.

Frequent cleaning and polishing will keep your Honda looking newer longer. Frequent cleaning also identifies you as an owner who values his motorcycle. A clean CRF is also easier to inspect and service.

While you're cleaning, be sure to look for damage, wear, and gasoline or oil leaks.

General Recommendations

- To clean your CRF you may use:
 - water
 - a mild, neutral detergent and water
 - a mild spray and wipe cleaner/polisher
 - a mild spray and rinse cleaner/degreaser and water
- Avoid products that contain harsh detergents or chemical solvents that could damage the metal, paint, and plastic on your CRF or discolor the seat and decals.
- If your CRF is still warm from recent operation, give the engine and exhaust system time to cool off.
- We recommend the use of a garden hose to wash your CRF. High pressure washers (like those at coin-operated car washes) can damage certain parts of your CRF. The force of water under extreme pressure can penetrate the dust seals of the suspension pivot points and steering head bearings-driving dirt inside and needed lubrication out.

If you use a high pressure washer, avoid spraying the following areas:

- wheel hubs
- muffler outlet
- under seat
- engine stop button
- brake master cylinders
- under fuel tank
- drive chain
- carburetor
- steering head bearings
- suspension pivot points

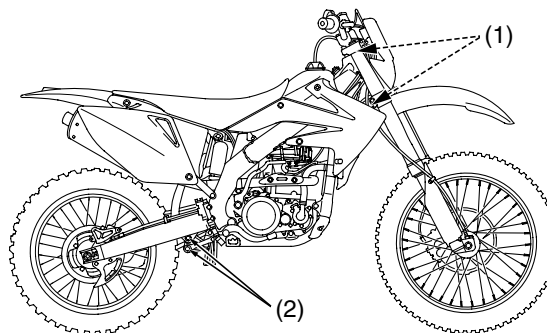

- (1) steering head bearings
- (2) suspension pivot points

NOTICE

High pressure water (or air) can damage certain parts of your CRF.

You may use Pro Honda Hondabrite, a multi-surface cleaner/degreaser, to remove both dirt and petroleum-based grime from paint, alloy, plastic, and rubber surfaces. Wet any heavy deposits with water first. Then spray on the Pro Honda Hondabrite and rinse with a garden hose at full pressure. Stubborn deposits may require a quick wipe with a sponge.

Washing Your Motorcycle with a Mild Detergent

1. Rinse your CRF thoroughly with cool water to remove loose dirt.
2. Fill a bucket with cool water. Mix in a mild, neutral detergent, such as dish washing liquid or a product made especially for washing motorcycles or automobiles.
3. Wash your CRF with a sponge or a soft towel. As you wash, check for heavy grime. If necessary, use a mild cleaner/degreaser to remove the grime.

Do not use steel wool to clean the frame as it could damage or discolor the frame surface. Muffler stain remover is for removing stains on the non-coated aluminum frame only.

4. After washing, rinse your CRF thoroughly with plenty of clean water to remove any residue.
5. Dry your CRF with a chamois or a soft towel.
6. Lubricate the drive chain to prevent rusting.
7. Start the engine and let it idle for several minutes. The engine heat will help dry moist areas.
8. As a precaution, ride at a slow speed and apply the brakes several times. This will help dry the brakes and restore normal braking performance.

If the inside of the headlight lens appears clouded immediately after washing, it should cleaner after a few minutes of riding.

Condensation Control

Some condensation can form within the transmission cavity as well. This is natural and just one more reason you should change the engine and transmission oil often.

After Cleaning Lubrication

There are some things you should do just after washing your CRF to help prevent rust and corrosion.

Once your CRF is clean and dry, you should protect any bare steel from rusting by applying a light coating of a rust-inhibitor. Lubricate the drive chain and drive sprocket after removing and thoroughly cleaning in solvent. Be sure the chain is wiped clean and is dry before applying the chain lube.

Follow the suggestions given in the pages of this manual for lubricating items such as the brake and clutch lever pivot points and footpeg pivot pins.

Aluminum Frame Maintenance

Aluminum corrodes when it comes in contact with dust, mud and road salt.

To remove stains, use Scotch-Brite Hand Pad #7447 (maroon) or an equivalent. Wet the pad and polish the surface using strokes parallel to the length of the frame.

Clean the frame using a wet sponge and a mild detergent, then rinse well with clean water. Dry the frame with a soft clean cloth, using strokes parallel to the length of the frame.

NOTICE

Do not use steel wool to clean the frame as it could damage or discolor the frame surface. Muffler stain remover (Scotch-Brite Hand Pad #7447-maroon) is for removing stains on the non-coated aluminum frame only.

Exhaust Pipe And Muffler Maintenance

The exhaust pipe and muffler are stainless steel, but may become stained by oil or mud.

To remove mud or dust, use a wet sponge and a liquid kitchen abrasive, then rinse well with clean water. Dry with chamois or a soft towel. If necessary, remove heat stains by using a commercially available fine texture compound. Then rinse by the same manner as removing mud or dust.

This section tells you how to fine tune your CRF for maximum competition performance.

Initial suspension adjustments should be performed after a minimum of two hours of easy break-in time.

Optional front and rear suspension springs are available in both stiffer and softer than standard rates, in order to tailor your CRF specifically for your weight, riding style and course conditions.

Follow the instructions given in the rear suspension sag setting section of *Rear Suspension Adjustments* to determine if your combined rider and sprung machine weight (rider fully dressed for competition and machine coolant, oil and fuel levels ready for competition) requires an optional stiffer or softer rear spring. The need for either optional rear spring may need to be balanced by installing the optional fork springs of a similar rate.

Front Suspension Adjustments.....	106
Rear Suspension Adjustments.....	120
Suspension Adjustments for Track Conditions	124
Suspension Adjustment Guidelines.....	125
Carburetor Adjustment & Tuning Tips	128
Chassis Adjustments.....	135
Gearing	136
Tire Selection for Track Conditions.....	137
Personal Fit Adjustments	138

Front Suspension Adjustments

The front suspension can be adjusted for the rider's weight and riding conditions by using one or more of the following methods:

- **Oil volume** — The effects of higher or lower fork oil level are only felt during the final 3.9 in (100 mm) of fork travel.
- **Compression damping** — Turning the compression damping screw adjusts how quickly the fork compresses.
- **Rebound damping** — Turning the rebound damping screw adjusts how quickly the fork extends.
- **Fork springs** — Optional springs are available in softer and stiffer types than the standard rate. (page 163)

The inverted fork on your CRF features sealed damper cartridges with dual (separate air and oil) chambers to prevent aeration. The design also isolates the oil in each fork tube/slider, which may contain air bubbles and/or metal particles, from the sealed cartridge to provide more consistent damping.

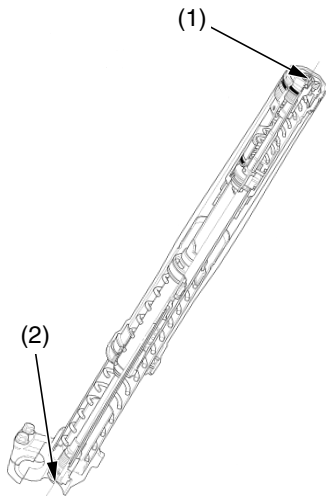

(1) compression damping adjuster
(2) rebound damping adjuster

Front Suspension Air Pressure

Air is an unstable gas which builds up pressure as it is worked (such as in a fork). Air pressure acts as a progressive spring and affects the entire range of fork travel. This means the fork action on your CRF will get stiffer during a race. For this reason, release built-up air pressure in the fork legs between motos. Be sure the fork is fully extended with the front tire off the ground when you release the pressure.

The standard air pressure is 0 psi (0 kPa, 0 kgf/cm²). You may relieve accumulated air pressure in the fork legs by using the pressure release screws. The front wheel should be off the ground before you release the pressure. The air pressure should be adjusted according to the altitude and outside temperature.

1. Place your CRF on an optional workstand or equivalent support with the front wheel off the ground.
2. Remove the pressure release screw (1).
3. Check that the O-ring (2) is in good condition.
4. Install and tighten the pressure release screw to the specified torque:
0.9 lbf·ft (1.2 N·m, 0.1 kgf·m)

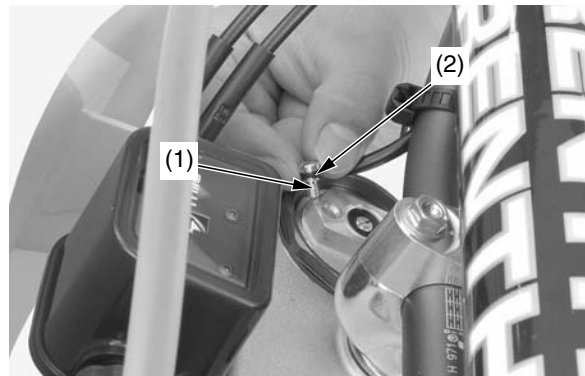

(1) pressure release screw (2) O-ring

Front Suspension Damping

Rebound Damping Adjustment

The fork rebound damping adjuster (1) has 16 positions or more. Turning the adjuster screw one full turn clockwise advances the adjuster four positions. To adjust the rebound damping to the standard setting, proceed as follows: Turn the adjuster clockwise until it will no longer turn (lightly seats). This is the full hard position. The adjuster is set in the standard position when the adjuster is turned counterclockwise 14 clicks. Make sure that both fork legs are adjusted to the same position.

Compression Damping Adjustment

This adjustment affects how quickly the fork compresses. The fork compression damping adjuster (2) screw has 16 positions or more. Turning the adjuster one full turn changes the adjuster four positions. To adjust the adjuster to the standard position, proceed as follows: Turn the adjuster clockwise until it will no longer turn (lightly seats). This is the full hard position. The adjuster is set in the standard position when the adjuster is turned counterclockwise 7 clicks. Make sure that both fork legs are adjusted to the same position.

Both compression and rebound damping can be increased by turning the adjuster clockwise.

NOTICE

Always start with full hard when adjusting damping.

Do not turn the adjuster screw more than the given positions or the adjuster may be damaged. Be sure that the rebound and compression adjusters are firmly located in a detent, and not between positions.

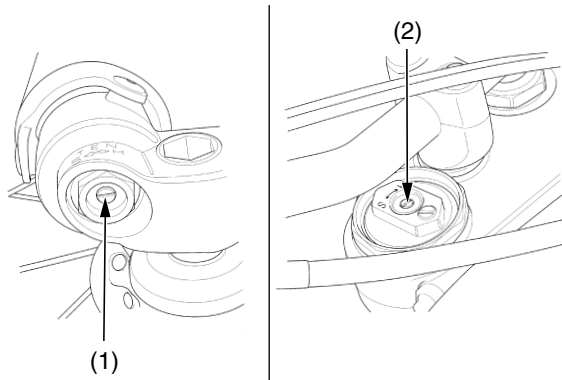

(1) rebound damping adjuster

(2) compression damping adjuster

Fork Springs

The fork springs in CRF's are about right for riders weighing between 150 and 160 lbs (less riding gear). So if you're a heavier rider, you have to go up on the oil level or get a stiffer spring. Do not use less oil than the minimum specified for each spring or there will be a loss of rebound damping control near full extension. If the fork is too hard on big bumps, turn the damping adjuster counterclockwise 1-turn and lower the oil level in increments of 0.2 oz (5 cc) in both fork legs until the desired performance is obtained. Do not, however, lower the oil level below the minimum oil level.

Minimum oil capacity:

Standard spring:	10.2 US oz (303 cm ³)
Softer spring:	10.4 US oz (308 cm ³)
Stiffer spring:	10.3 US oz (306 cm ³)

When adjusting oil levels, bear in mind that the air in the fork will increase in pressure while riding; therefore, the higher the oil level, the higher the eventual pressure of any air in the fork.

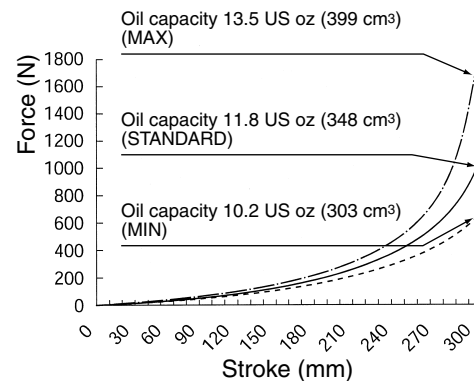

Front Suspension Disassembly

- If your CRF is brand-new, put enough part-throttle break-in time (about one hour) on it to ensure that the suspension has worked in.
- For optimum performance, and extended fork life, the fork should be completely disassembled and cleaned after the first three hours of riding. See the Service Manual or your Honda dealer for this service.
- When disassembling the fork, turn the rebound (1) and compression (2) damping adjusters counterclockwise to the softest position to prevent damaging the adjustment needle (be sure to record the number of turns from the starting position).

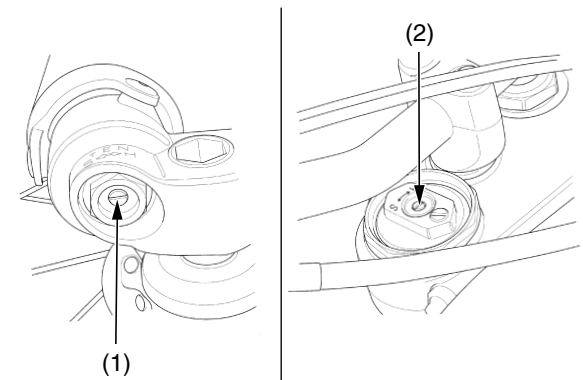

(1) rebound damping adjuster

(2) compression damping adjuster

Front Suspension Adjustments

1. Place your CRF on the optional workstand or equivalent support with the front wheel off the ground.
2. Remove the front visor bolts (3) and front visor (4).

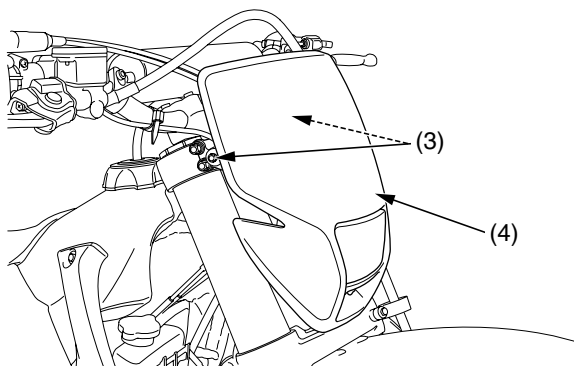

(3) front visor bolts
(4) front visor

3. Disconnect the headlight connector (5).



(5) headlight connector

4. Remove the handlebar pad. Remove the handlebar holder nuts, washers, mounting rubbers (6) and handlebar (7).

NOTICE

Keep the master cylinder upright to prevent air from entering system.

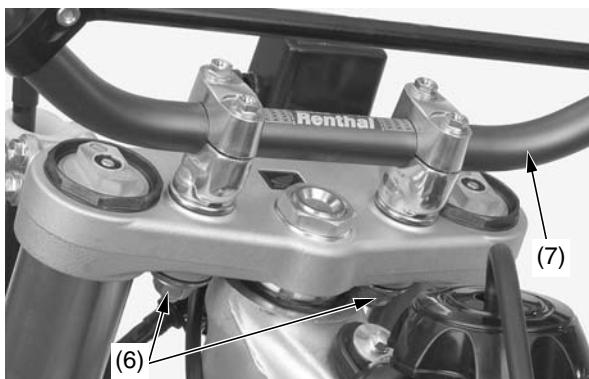

(6) handlebar holder nuts/washers/mounting rubbers
(7) handlebar

5. Loosen the upper pinch bolts (8).
6. Loosen the fork damper (9), using the lock nut wrench but do not remove it yet.

NOTICE

Do not use an adjustable wrench to loosen the fork damper: it may damage them.

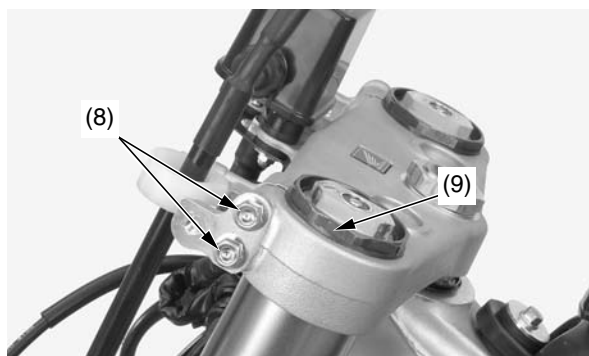

(8) upper pinch bolts
(9) fork damper

7. Remove the disc cover (10) by removing the bolts (11).

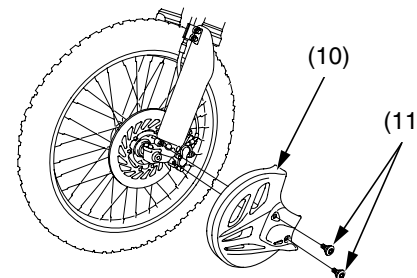

(10) disc cover
(11) bolts

8. Remove the tripmeter cable (12) and front axle nut (13) and loosen the axle pinch bolts (14) on both fork legs.
9. Pull the front axle shaft (15) out of the wheel hub and remove the front wheel.

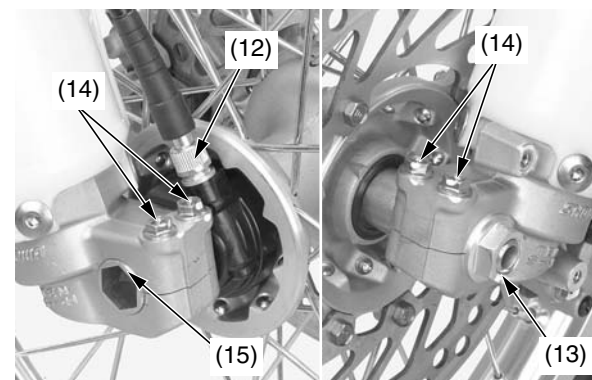

(12) tripmeter cable
(13) front axle nut
(14) axle pinch bolts
(15) front axle shaft

10. Remove the fork protector bolts (16), tripmeter cable clamp bolts (17) and brake hose clamp bolts (18) and fork protectors (19). Remove the brake caliper bolts (20) and brake caliper (21). The fork protector bolts and brake caliper bolts have a locking agent applied.

Front Suspension Adjustments

Do not support the brake caliper by the brake hose. Do not operate the front brake lever after the front wheel is removed. To do so will cause difficulty in fitting the brake disc between the brake pads.

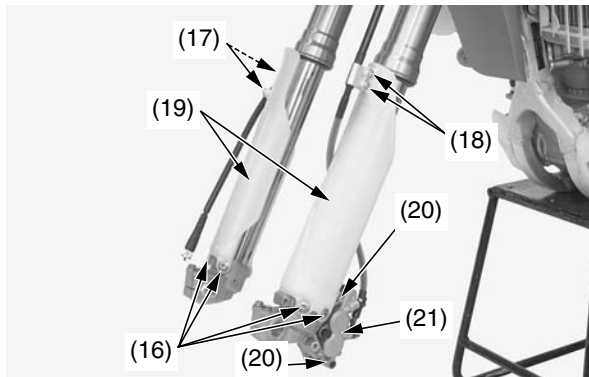

(16) fork protector bolts
(17) tripmeter cable clamp bolts
(18) brake hose clamp bolts
(19) fork protectors
(20) brake caliper bolts
(21) brake caliper

11. Loosen the fork leg lower pinch bolts (22), then pull the fork legs down and out.

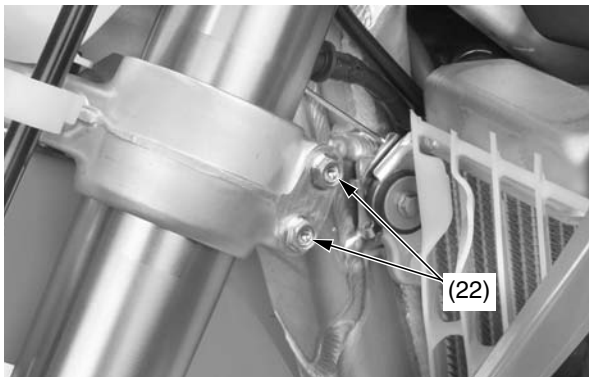

(22) lower pinch bolts

12. Clean the fork assembly, especially the sliding surface (23) of the slider and dust seal (24).
13. Record the rebound damping adjuster position and turn the adjuster counterclockwise until it stops.
14. Measure the length (25) between the axle holder and outer tube and record it before disassembling the fork.

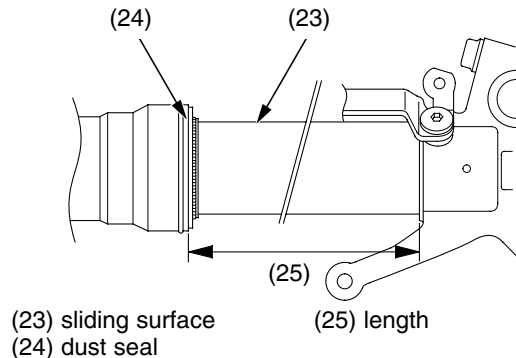

(23) sliding surface
(24) dust seal
(25) length

15. Hold the outer tube (26), then remove the fork damper (27) from the outer tube using the lock nut wrench (28). Gently slide the outer tube down onto the lower end of the slider (29).

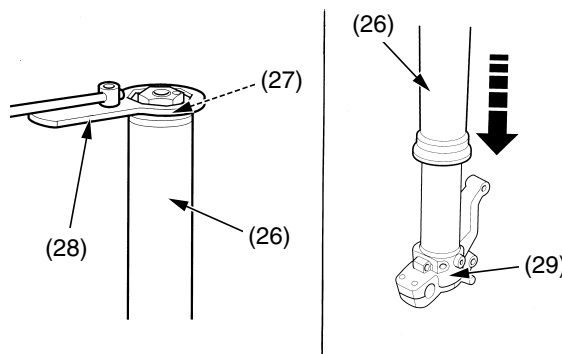

(26) outer tube
(27) fork damper
(28) lock nut wrench
(29) slider, lower end

NOTICE

The outer tube (26) can drop on the slider (30) and damage the fork dust seal (24) and guide bushing (31) when the fork damper is removed. To avoid damage hold both the outer tube and slider when removing the fork damper.

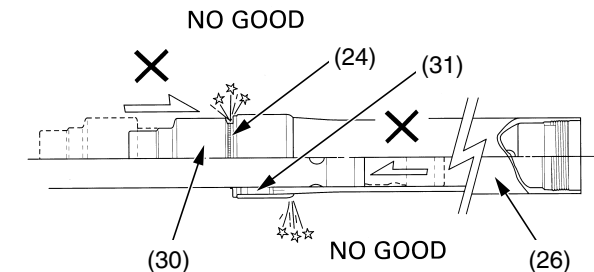

(24) dust seal
(26) outer tube
(30) slider
(31) guide bushing

16. Drain the fork oil from the outer tube (26). Drain the fork oil from the oil hole (32) of the fork damper.

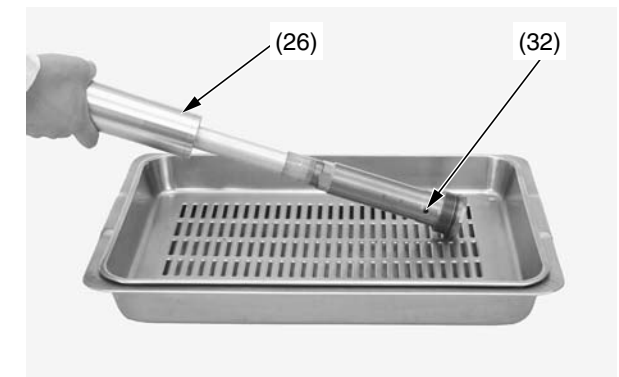

(26) outer tube
(32) oil hole

(cont'd)

Front Suspension Adjustments

- Temporarily install the fork damper to the outer tube.
- Set the lower end (axle holder) (33) of the slider in a vise with a piece of wood or soft jaws to avoid damage.

NOTICE

Overtightening the vise can damage the axle holder.

- Loosen the fork center bolt (34).

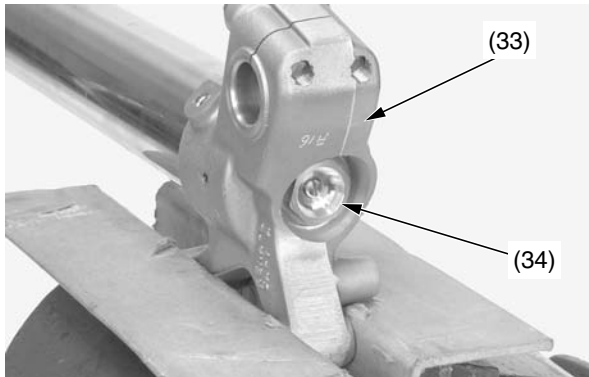

(33) axle holder (34) fork center bolt

- Push out the fork center bolt from the axle holder of the slider by pushing the fork damper.
- Make the mechanic's stopper tool out of a thin piece of steel (1.0 mm thick) as shown if you do not have the special tool.

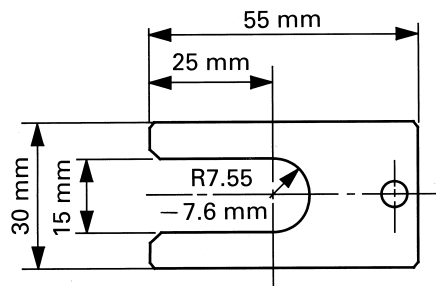

- Apply pressure to the fork damper and insert a special tool or mechanic's stopper tool (35) (see below) between the axle holder (33) and lock nut (36).
- Hold the lock nut and remove the fork center bolt (34) from the fork damper.

NOTICE

Do not remove the lock nut from the fork damper piston rod. If the lock nut is removed, the piston rod will fall in the fork damper and you can not reassemble the fork damper.

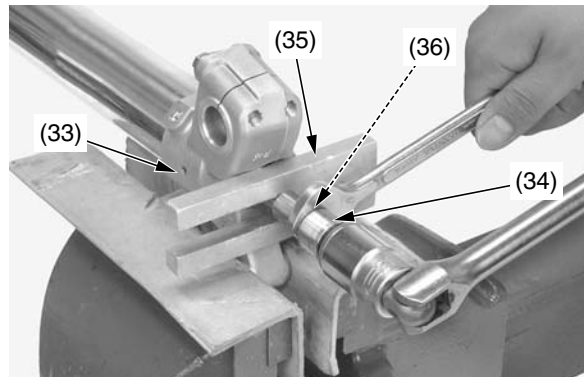

(33) axle holder (34) fork center bolt (35) stopper tool (36) lock nut

- Remove the push rod (37) from the fork damper.
- Remove the special tool or mechanic's stopper tool between the axle holder (33) and lock nut (36) while applying pressure to the fork cap.

NOTICE

Be careful not to damage the lock nut and fork center bolt hole.

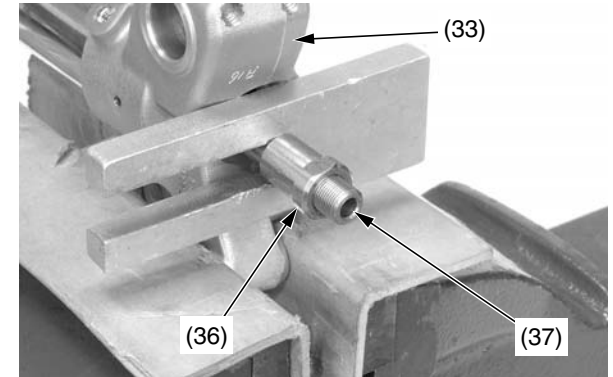

(33) axle holder (36) lock nut (37) push rod

- Remove the fork damper assembly (38) from the fork assembly (39). Remove the fork from the vise. Remove the fork spring (40) from the fork.

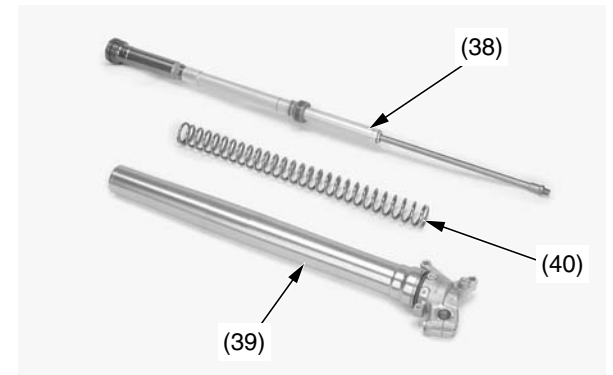

(38) fork damper assembly (39) fork assembly (40) fork spring

Damper Oil Change

1. Place the fork damper (2) in a vise with a piece of wood or soft jaws to avoid damage.
2. Loosen the fork cap assembly (1) while holding the fork damper (2) using the lock nut wrench (3).

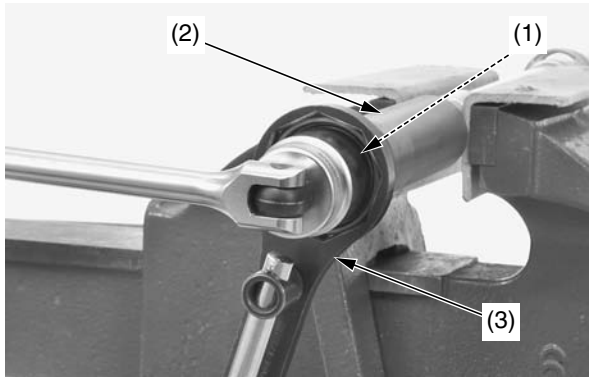

(1) fork cap assembly (3) lock nut wrench
(2) fork damper

3. Remove the fork cap assembly (1) from the fork damper (2).

Be careful not to damage the fork cap bushing. Do not disassemble the fork cap assembly. Replace the fork cap as an assembly if it is damaged.

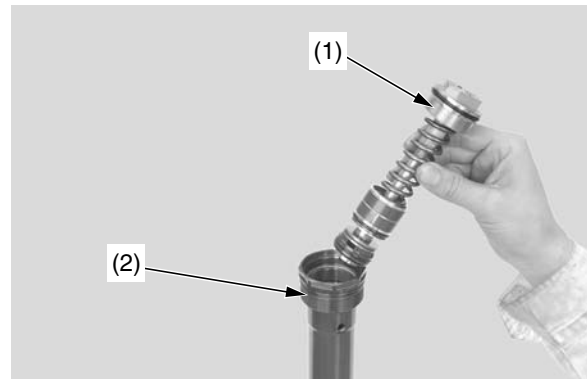

(1) fork cap assembly (2) fork damper

4. Empty the fork oil from the fork damper (2) by pumping the damper rod several times.

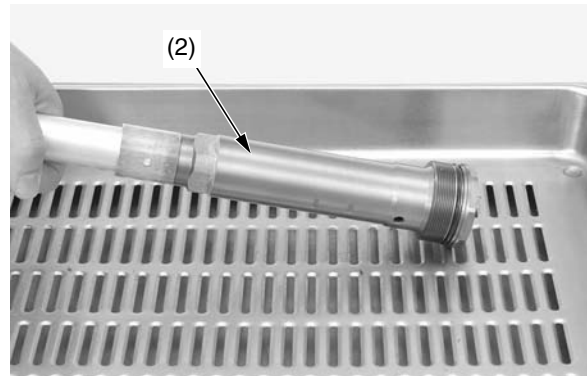

(2) fork damper

5. Clean the fork cap and fork damper threads.

6. Extend the fork damper piston rod to maximum. Pour the recommended fork oil into the fork damper.

Recommended Oil:
Pro Honda HP Fork Oil 5 W or equivalent
Recommended Amount:
6.5 US oz (192 cc, 6.8 Imp oz)

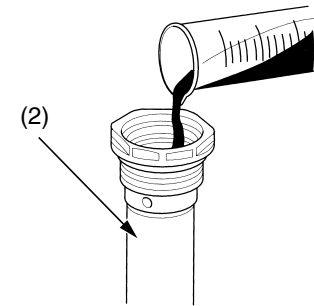

(2) fork damper

7. Pump the fork damper piston rod (4) slowly several times to bleed the air from the fork damper (2).

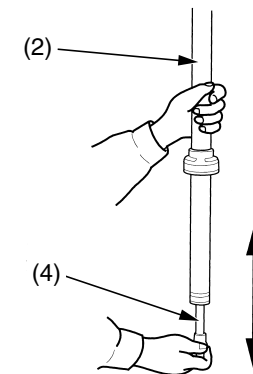

(2) fork damper

(4) fork damper piston rod

(cont'd)

Front Suspension Adjustments

8. Extend the fork damper piston rod to maximum. Adjust the oil level of the fork damper (2) as shown.
Oil Level: 1.65 – 1.85 in (42 – 47 mm)

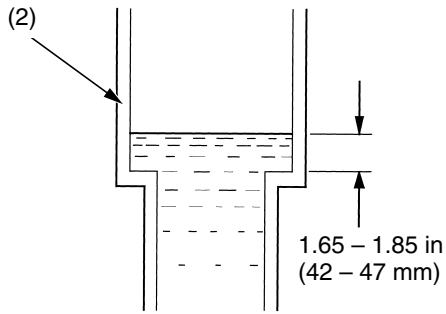

(2) fork damper

9. Apply fork oil to the bushing (5) and new O-ring (6) on the fork cap assembly (1). Extend the fork damper piston rod to maximum, holding it, install the fork cap assembly to the fork damper (2).

Be careful not to damage the fork cap bushing.

If it is difficult to install the fork cap assembly, the fork damper oil level might be higher than standard oil level. Inspect the fork damper oil level again.

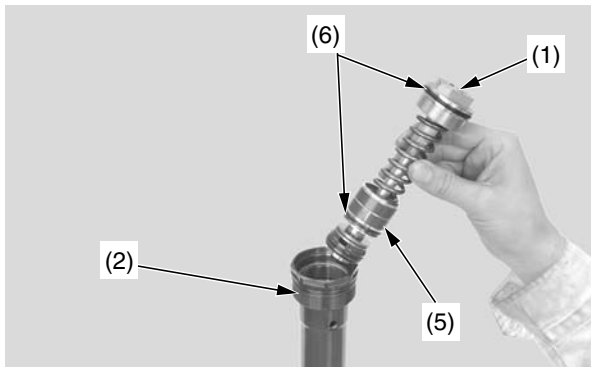

(1) fork cap assembly (5) bushing
(2) fork damper (6) O-ring

10. Tighten the fork cap assembly (1) while holding the cut out of the fork damper (2) using the lock nut wrench (3) to the specified torque:
22 lbf·ft (30 N·m, 3.1 kgf·m)

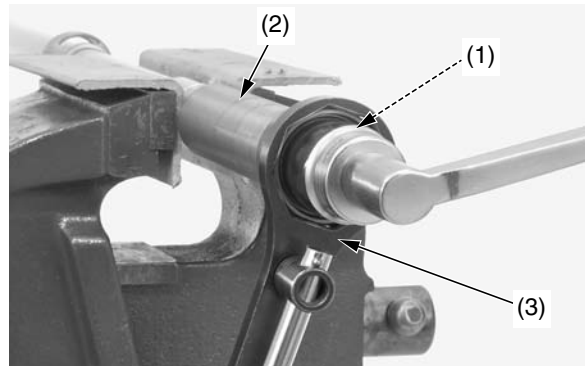

(1) fork cap assembly (3) lock nut wrench
(2) fork damper

11. Hold the fork damper (2) in an upright position and pump the fork damper piston rod (4) to 3.9 in (100 mm) slowly several times.

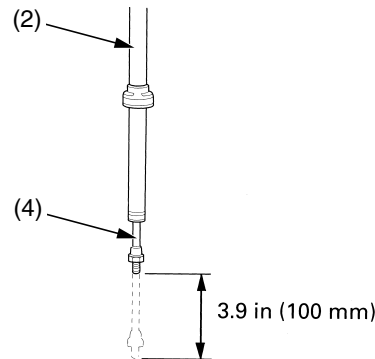

(2) fork damper (4) fork damper piston rod

12. Screw in the lock nut (7) to the fork damper piston rod (4) fully.

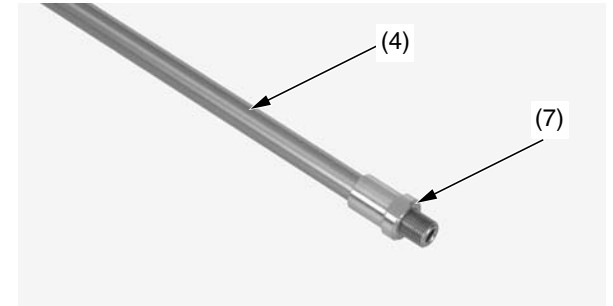

(4) fork damper piston rod (7) lock nut

Turn the rebound adjuster and compression adjuster counterclockwise to the softest position. Check the fork damper piston rod sliding surface for damage.

Apply fork oil to the fork damper piston rod sliding surface.

Cover the fork damper piston rod end with soft jaws to prevent fork damage.

NOTICE

Be careful not to bend or damage the fork damper piston rod when the piston rod is stroked.

Front Suspension Adjustments

13. Blow the extra oil off to the fork damper spring chamber (8) by pumping the fork damper piston rod to full stroke.

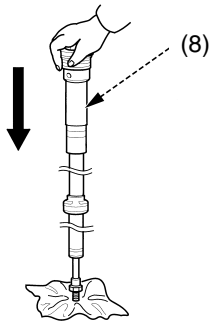

(8) fork damper spring chamber

14. Drain the extra oil from the oil hole (9).

By doing this procedure, about 0.6 US oz (17 cm³) of fork fluid will be drained from the damper spring chamber through the oil hole and cause 5.9 US oz (175 cm³) of fork fluid to be left in the chamber.



(9) oil hole

15. Blow out the oil from the fork damper spring chamber using compressed air to the oil hole. Wipe the oil completely off the fork damper.
16. If you can not use compressed air, remove the pressure release screw (10) on the fork cap (11). Hold the fork damper up side down for 10 minutes and drain the oil from the fork damper spring chamber.

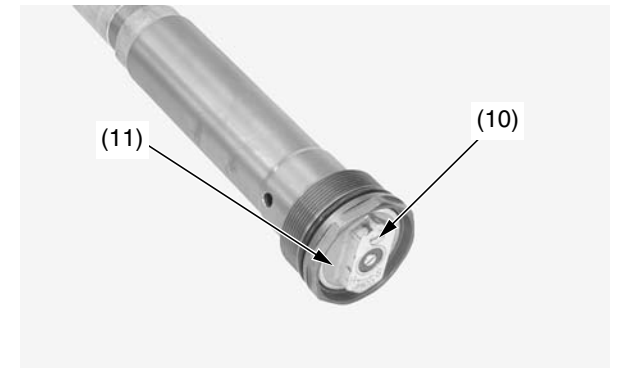

(10) pressure release screw

(11) fork cap

Front Suspension Adjustments

Fork Assembly

1. Drain the fork oil from the outer tube/slider (1) by placing it upside down. (About 7 cc of fork oil will be left in the outer tube/slider when it is left inverted for about 20 minutes at 20°C)

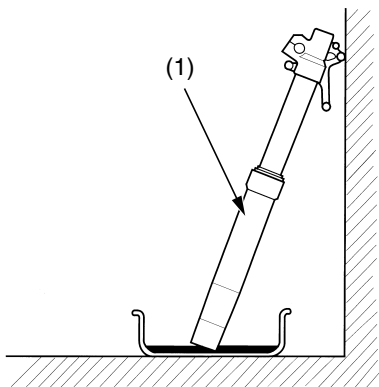

(1) outer tube/slider

Amount of fork oil left in the fork (without damper and spring) unit: cc

minute °C/°F	5	10	20	35	55	85	145
30/86	7.1	5.9	4.7	4.2	3.5	3.5	3.5
20/68	10.6	8.2	7.1	5.9	5.6	4.7	4.7
10/50	11.8	8.3	7.2	6.2	5.8	4.9	4.8
0/32	12.9	10.6	9.4	8.2	7.9	7.1	5.9

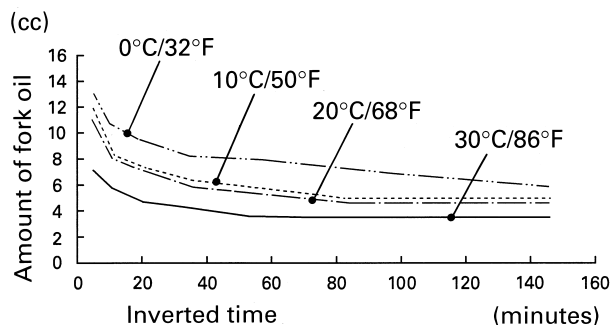

2. Tighten the lock nut (2) fully and measure the thread length (A) as shown.

Standard: 0.43 – 0.51 in (11 – 13 mm)

Wipe the oil completely off the fork damper.

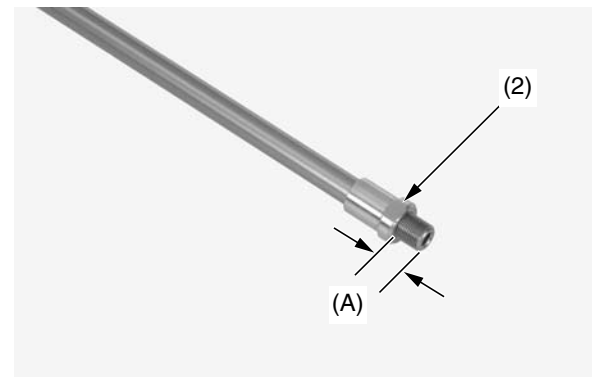

(2) lock nut

(A) thread length

3. Using compressed air, blow all oil off the fork spring (3). Install the fork spring (3). Install the fork damper assembly (4) to the outer tube/slider (1).

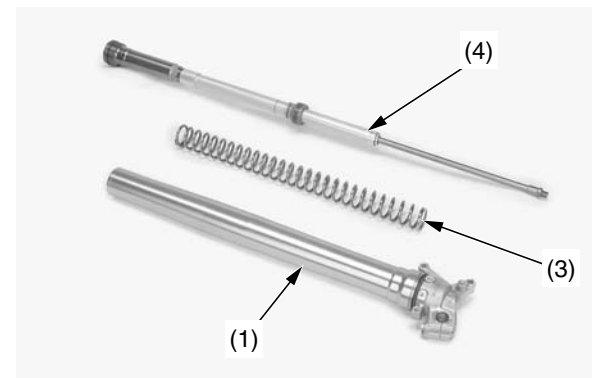

(1) outer tube/slider

(4) fork damper assembly

(3) fork spring

Front Suspension Adjustments

- Place the lower end (axle holder) of the slider in a vise with a piece of wood or soft jaws to avoid to damage.

NOTICE

Overtightening the vise can damage the axle holder.

- Temporarily install the fork damper to the fork. Push out the fork damper piston rod from the axle holder of the slider by pushing the fork damper. Apply pressure to the fork damper and insert the special tool or mechanic's stopper tool (5) between the axle holder and lock nut (2). Measure the thread length again. Standard: 0.43 – 0.51 in (11 – 13 mm)
- Install the push rod (6) into the fork damper piston rod until it stops. Check the push rod installation by turning the push rod right and left.
- Apply fork oil to a new O-ring (7) and install it to the fork center bolt (8). Apply locking agent to the fork center bolt threads. Install the fork center bolt to the fork damper piston rod aligning the fork center bolt adjusting rod (9) with the push rod. Tighten the fork center bolt fully by hand.

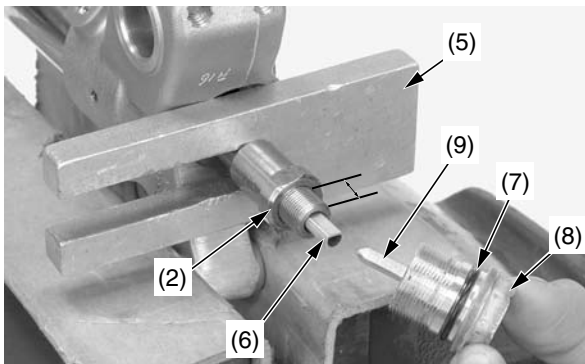

- (2) lock nut
- (5) stopper tool
- (6) push rod
- (7) O-ring
- (8) fork center bolt
- (9) adjusting rod

- Measure the length of the lock nut (2) and fork center bolt (8) clearance. Standard: 0.06 – 0.08 in (1.5 – 2.0 mm)

If the clearance is out of specification, check the lock nut and center bolt installation.

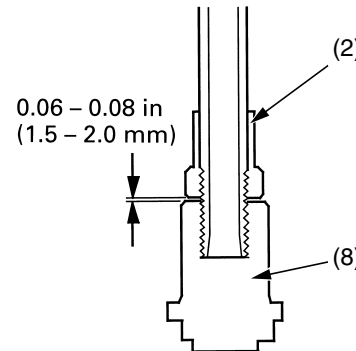

- (2) lock nut
- (8) fork center bolt

- Tighten the lock nut (2) to the fork center bolt (8) closely by hand. Tighten the lock nut to the specified torque:
16 lbf·ft (22 N·m, 2.2 kgf·m)

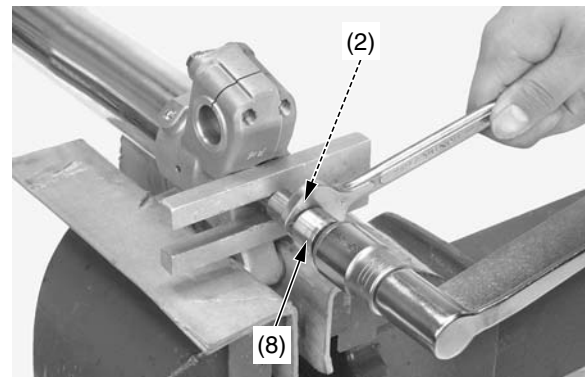

- (2) lock nut
- (8) fork center bolt

- Remove the special tool or mechanic's stopper tool while applying pressure to the fork damper.

Install the fork center bolt (8) to the axle holder and tighten it to the specified torque:
51 lbf·ft (69 N·m, 7.0 kgf·m)

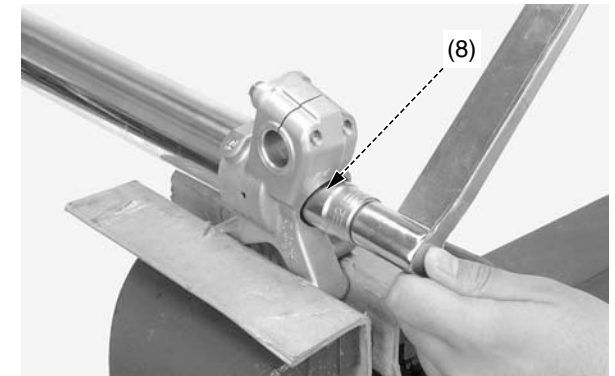

- (8) fork center bolt

- Measure the length between the axle holder and outer tube. Standard: 317 ± 2 mm
- Compare the length (10) at assembly and at disassembly. They should be the same length.

If the length at assembly is longer than at disassembly, check the fork center bolt and lock nut installation.

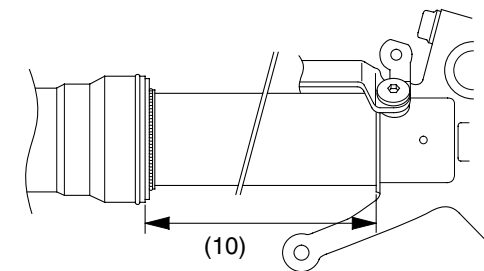

- (10) length

(cont'd)

Front Suspension Adjustments

13. Pour the recommended fork oil (11) into the outer tube/slider (1).

Recommended Oil:
Pro Honda HP Fork Oil 5 W or equivalent.

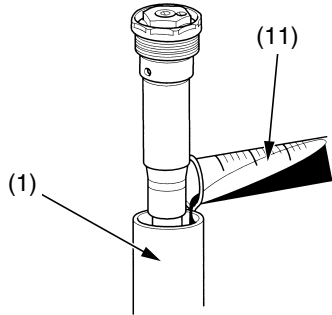

(1) outer tube/slider (11) fork oil

Fork Oil Capacity:

Standard (0.42 kgf/mm) Fork Spring

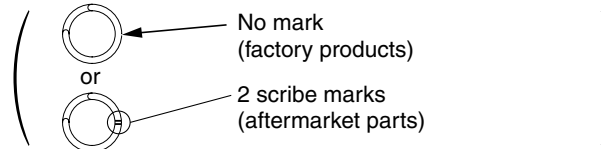

Standard oil capacity	11.8 US oz (348 cm ³)	
Maximum oil capacity	13.5 US oz (399 cm ³)	Slightly stiffer as it nears full compression.
Minimum oil capacity	10.2 US oz (303 cm ³)	Slightly softer as it nears full compression.

Optional Softer (0.40 kgf/mm) Fork Spring

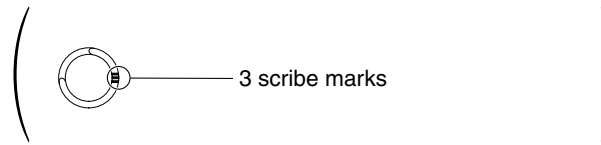

Standard oil capacity	11.9 US oz (353 cm ³)	
Maximum oil capacity	13.7 US oz (404 cm ³)	Slightly stiffer as it nears full compression.
Minimum oil capacity	10.4 US oz (308 cm ³)	Slightly softer as it nears full compression.

Optional Stiffer (0.44 kgf/mm) Fork Spring

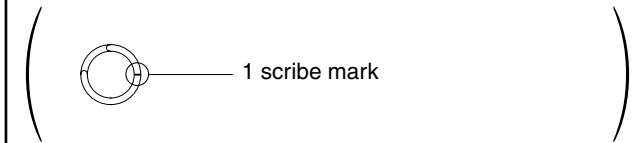

Standard oil capacity	11.9 US oz (351 cm ³)	
Maximum oil capacity	13.6 US oz (402 cm ³)	Slightly stiffer as it nears full compression.
Minimum oil capacity	10.3 US oz (306 cm ³)	Slightly softer as it nears full compression.

Be sure the oil capacity is the same in both fork legs.

Front Suspension Adjustments

14. Check that the O-ring (12) on the fork damper assembly (4) is in good condition. Apply the recommended fork oil to the O-ring.
15. Pull up the outer tube/slider (1) slowly and install the fork damper assembly (4) into the outer tube.

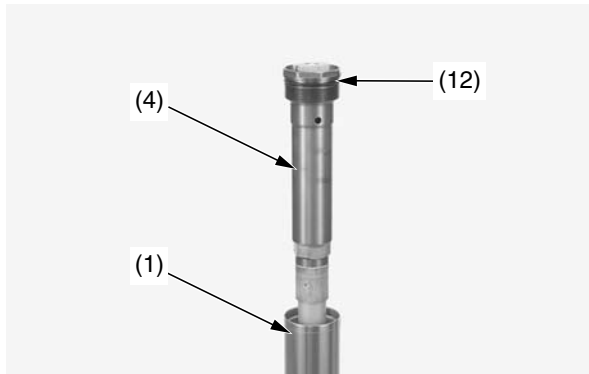

(1) outer tube/slider
(4) fork damper assembly
(12) O-ring

16. Insert both fork legs into the fork clamps. Tighten the fork lower pinch bolts (13) to the specified torque.
15 lbf-ft (20 N-m, 2.0 kgf-m)

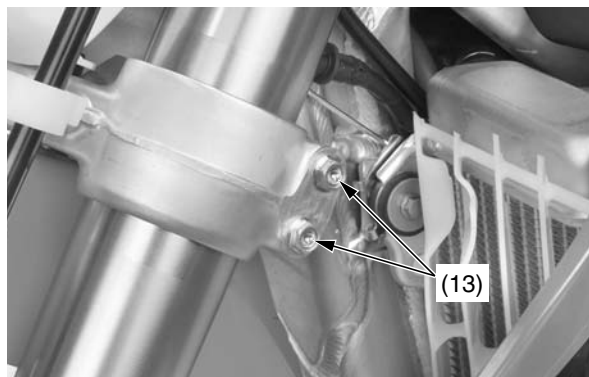

(13) lower pinch bolts

17. Tighten the fork damper assembly (4) to the specified torque using the lock nut wrench (14).
Actual:
25 lbf-ft (34 N-m, 3.5 kgf-m)
Torque wrench scale reading:
23 lbf-ft (31 N-m, 3.2 kgf-m), using a 20 in (50 cm) long torque wrench.

When using the lock nut wrench, use a 20-inch long deflecting beam type torque wrench. The lock nut wrench increases the torque wrench's leverage, so the torque wrench reading will be less than the torque actually applied to the fork damper.

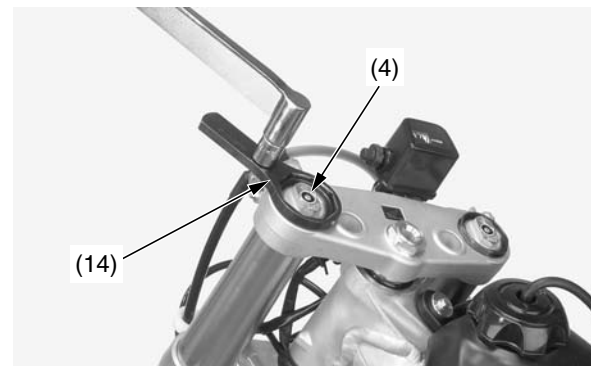

(4) fork damper assembly (14) lock nut wrench

18. For ease of releasing air pressure after the forks are installed, Loosen the lower pinch bolts and position the outer tubes so that the pressure release screws are in front of the rebound damping adjusters. Align (15) the top surface of the upper fork clamp (16) with the outer tube/slider (1) upper surface as shown.

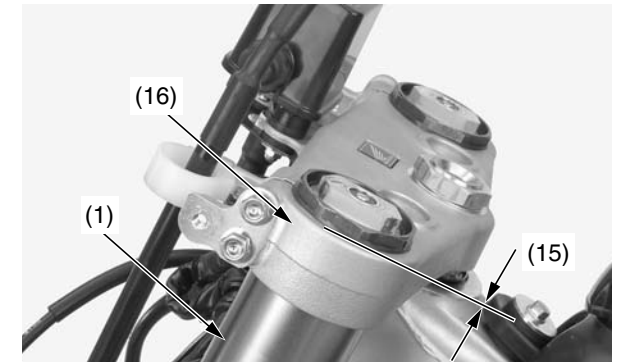

(1) outer tube/slider
(15) align
(16) upper fork clamp

19. Tighten the fork lower pinch bolts (13) to the specified torque:
15 lbf-ft (20 N-m, 2.0 kgf-m)
20. Tighten the fork upper pinch bolts (17) to the specified torque:
16 lbf-ft (22 N-m, 2.2 kgf-m)

NOTICE

Over-tightening the pinch bolts can deform the outer tubes. Deformed outer tubes must be replaced.

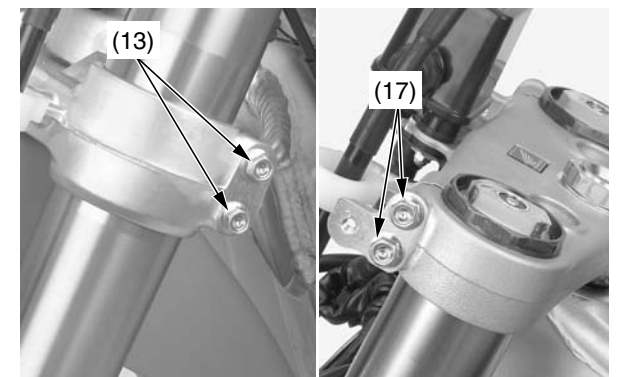

(13) lower pinch bolts (17) upper pinch bolts

(cont'd)

Front Suspension Adjustments

21. Clean the threads of the fork protector bolts (18) and axle holder thoroughly. Apply locking agent to the fork protector bolt threads. Install the fork protectors (19), fork protector bolts, brake hose clamp bolts (20) and tripmeter cable clamp bolts (21). Tighten the fork protector bolts to the specified torque:
5.2 lbf·ft (7 N·m, 0.7 kgf·m)

22. Align the brake caliper (23) and hose with the left fork leg, making sure that the brake hose is not twisted. An improperly routed brake hose may rupture and cause a loss of braking efficiency. Route the hose carefully.

23. Clean the threads of the caliper mounting bolts (22) and brake caliper thoroughly. Apply locking agent to the bolt threads. Install the brake caliper (23) on the slider and tighten the caliper mounting bolts to the specified torque:
22 lbf·ft (30 N·m, 3.1 kgf·m)

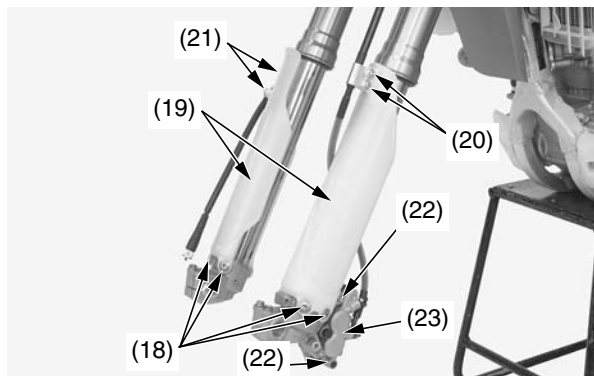

(18) fork protector bolts
(19) fork protectors
(20) brake hose clamp bolts
(21) tripmeter cable clamp bolts
(22) caliper mounting bolts
(23) brake caliper

24. Check the left side collar (24) and tripmeter gear box (25) for wear or damage. Install the left side collar to the left wheel hub. Install the tripmeter gear box while aligning its tabs (26) of the tripmeter gear box with the grooves (27) on the right wheel hub.

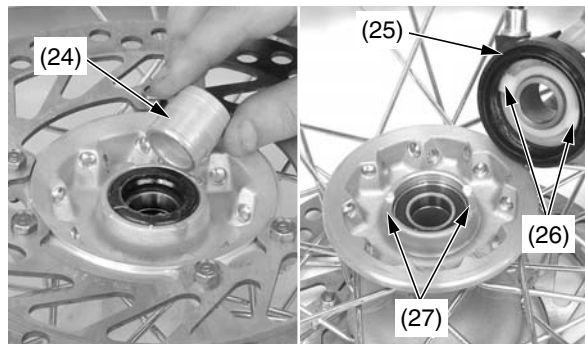

(24) left side collar
(25) tripmeter gear box
(26) tabs
(27) grooves

25. Clean the clamping surface of the axle and axle holders. Install the front wheel (28) between the fork legs while inserting the disc between the pads, and align (29) the tab of the tripmeter gear box as shown. Check that the tripmeter gear box O-ring (30) is in good condition, replace it if necessary. Apply a thin layer of grease to the axle (31) and insert the axle from the right side.

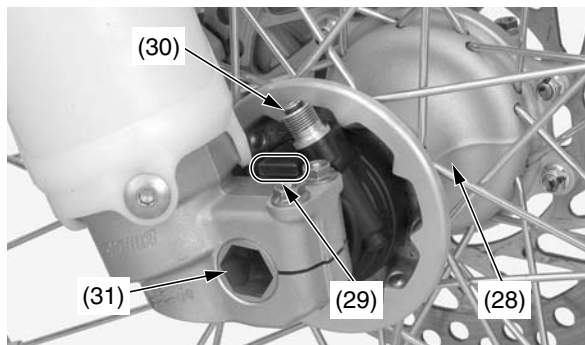

(28) front wheel
(29) align
(30) O-ring
(31) axle

26. Install and tighten the axle nut (32) to the specified torque.
65 lbf·ft (88 N·m, 9.0 kgf·m)
Tighten the left axle pinch bolts (33) to the specified torque.
15 lbf·ft (20 N·m, 2.0 kgf·m)

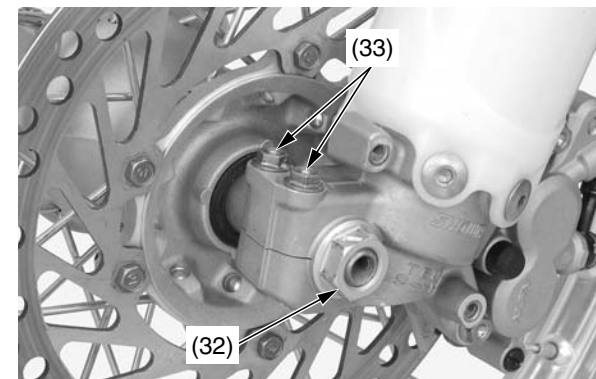

(32) axle nut
(33) left axle pinch bolts

27. Install the handlebar (34), mounting rubbers, washers and handlebar holder nuts (35) and tighten the handlebar holder nuts to the specified torque:
32 lbf·ft (44 N·m, 4.5 kgf·m)

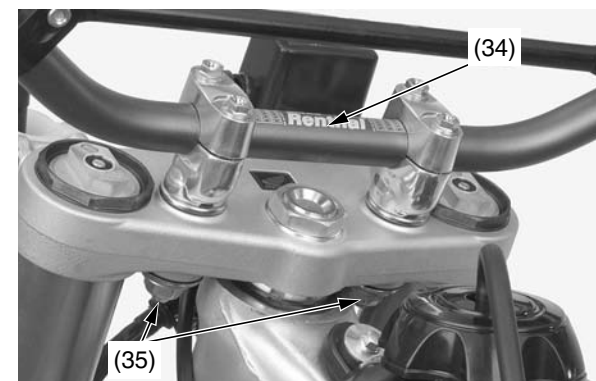

(34) handlebar
(35) mounting rubbers/washers/handlebar holder nuts

Front Suspension Adjustments

28. Install the front visor by aligning its grommets (36) with the tabs (37) on the steering stem.

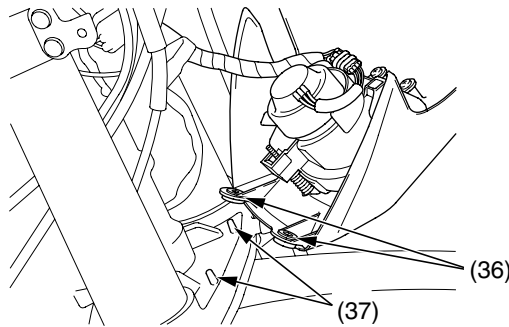

(36) front visor grommets (37) tabs

29. Install and tighten the front visor bolts (38). Install the handlebar pad (39).

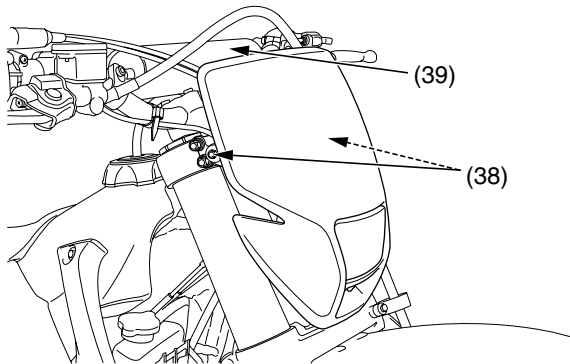

(38) front visor bolts (39) handlebar pad

30. With the front brake applied, pump the fork up and down several times to seat the axle and check front brake operation.

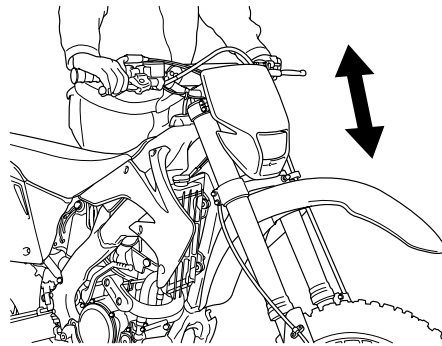

31. While keeping the forks parallel, alternately tighten the right axle pinch bolts (40) to the specified torque:
15 lbf-ft (20 N·m, 2.0 kgf·m)

NOTICE

To avoid damage when torquing the axle pinch bolts, be sure the axle is seated firmly onto the left fork leg clamp inner surface.

32. Install the tripmeter cable (41) and tighten the lock nut securely.

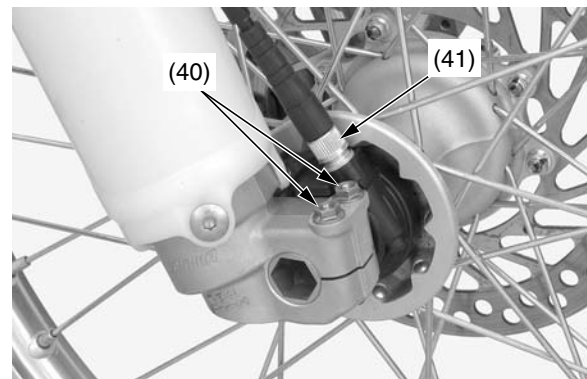

(40) right axle pinch bolts (41) tripmeter cable

33. Install the disc cover (42) and tighten the bolts (43) to the specified torque:
10 lbf-ft (13 N·m, 1.3 kgf·m)

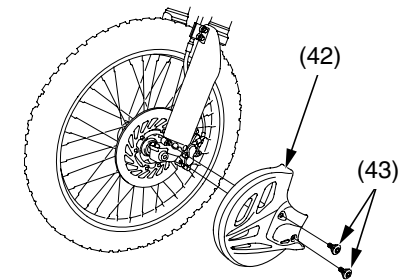

(42) disc cover (43) bolts

34. Turn the rebound damping (44) and compression damping (45) adjuster back to their original setting.

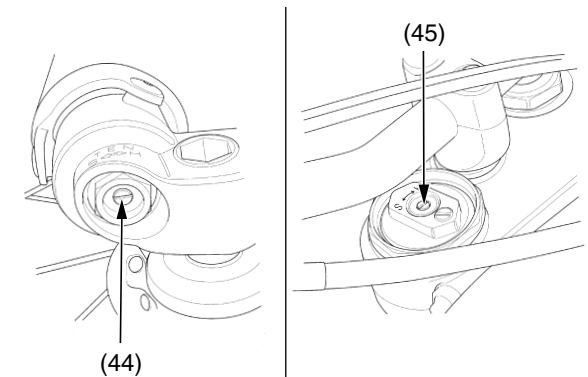

(44) rebound damping adjuster

(45) compression damping adjuster

Rear Suspension Adjustments

The rear suspension can be adjusted for the rider's weight and riding conditions by changing the spring pre-load and the rebound and compression damping.

The rear shock absorber assembly includes a damper unit that contains high pressure nitrogen gas. Do not attempt to disassemble, service, or dispose of the damper; see your Honda dealer. The instructions found in this owner's manual are limited to adjustments of the shock assembly only.

Puncture or exposure to flame may also result in an explosion, causing serious injury. Service or disposal should only be done by your authorized Honda dealer or a qualified mechanic, equipped with the proper tools, safety equipment and the Honda Service Manual.

If your CRF is new, put enough part-throttle break-in time (about one hour) on it to ensure that the suspension has worked in.

Rear Suspension Spring Pre-Load

Pre-load should be adjusted when the engine is cold because it is necessary to remove the muffler (page 62).

An optional pin spanner is available for turning the lock nut and adjusting nut to adjust spring pre-load.

1. Place your CRF on an optional workstand or equivalent support with the rear wheel off the ground.
2. Loosen the connecting tube clamp screw and subframe mounting upper bolt, and remove the rear subframe mounting lower bolts, then lift the subframe. See page 39.

3. Check that the spring pre-load is adjusted to the standard length. Adjust as necessary by loosening the lock nut (1) and turning the adjusting nut (2).
Each complete turn of the adjusting nut changes the spring length by 0.06 in (1.5 mm).
4. After adjustment, hold the adjusting nut and tighten the lock nut to the specified torque: 32 lbf-ft (44 N·m, 4.5 kgf·m)

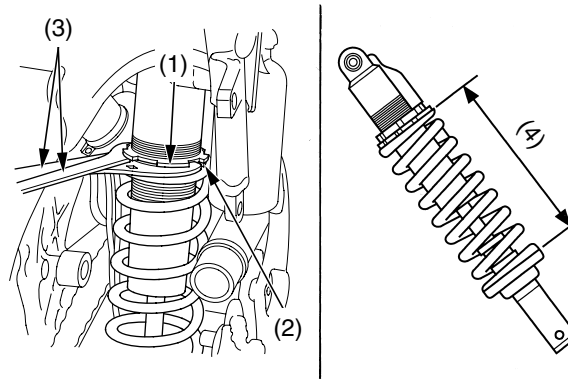

- (1) lock nut (3) pin spanners
(2) adjusting nut (4) spring length

To increase spring pre-load:

Loosen the lock nut with the optional pin spanner (3) and turn the adjusting nut to shorten the spring length (4). Do not shorten to less than: 9.6 in (243 mm)

To decrease spring pre-load:

Loosen the lock nut with the optional pin spanner (3) and turn the adjusting nut to increase the spring length (4). Do not increase to more than: 10.14 in (257.6 mm)

Each turn of the adjuster changes spring length and spring pre-load. One turn equals: spring length/spring pre-load: 0.06 in (1.5 mm) / 15.9 lbs (7.2 kg)

Pin spanners should be used for turning the lock nut and adjusting nut. See page 163 for optional pin spanners.

Spring pre-load length (Standard spring)
Standard: 10.10 in (256.6 mm)
Min. : 9.6 in (243 mm)

Spring pre-load length (Optional spring)
Min. (Softer, 4.55 kgf/mm): 9.7 in (246 mm)
Min. (Stiffer, 5.00 kgf/mm): 9.7 in (246 mm)
Min. (Stiffer, 5.20 kgf/mm): 9.8 in (248 mm)

Rear Suspension Damping

Compression Damping

Compression damping may be adjusted in two stages with separate adjusters.

The high speed damping adjuster (1) is effective when damping adjustment is desired for high speed operation. The low speed damping adjuster (2) should be used when damping adjustment is desired at relatively low speeds.

- Both the high and low speed compression damping can be increased by turning the appropriate adjuster clockwise.
- Adjust the high speed compression adjuster in 1/12 turn increments.
- Be sure the low speed compression adjuster is firmly located in a detent, and not between positions.

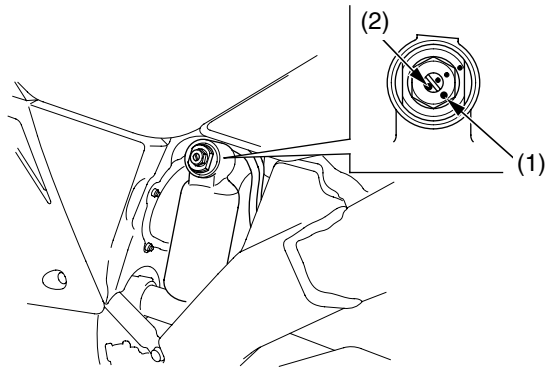

(1) high speed damping adjuster
(2) low speed damping adjuster

High Speed Damping:

The high speed damping can be adjusted by turning the hexagonal portion of the compression adjuster.

To adjust to the standard position:

1. Turn the adjuster clockwise until it will no longer turn (lightly seats). This is the full hard setting.
2. Turn the adjuster counterclockwise 1 3/4 – 2 1/4 turns and the punch marks are aligned.

Low Speed Damping:

The low speed damping can be adjusted by turning the center screw of the compression adjuster.

The low speed compression adjuster has 13 positions or more.

Turning the adjuster one full turn clockwise advances the adjuster 4 positions.

To adjust to the standard position:

1. Turn the adjuster clockwise until it will no longer turn (lightly seat). This is the full hard setting.
2. Turn the adjuster counterclockwise 12 clicks and the punch marks are aligned.

Rebound Damping

The rebound damping adjuster (3) is located at the lower end of the shock absorber.

It has 17 positions or more. Turning the adjuster one full turn advances the adjuster 4 positions.

- Rebound damping can be increased by turning the adjuster clockwise.
- Be sure that the rebound adjuster is firmly located in a detent, and not between positions.

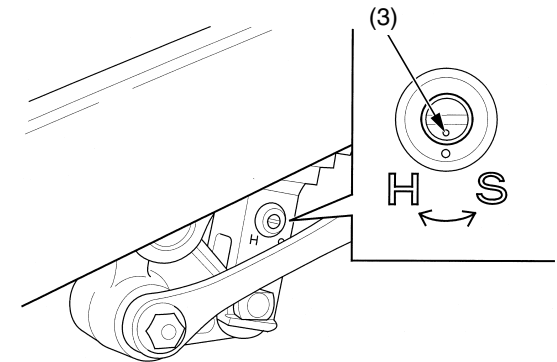

(3) rebound damping adjuster

To adjust to the standard position:

1. Turn the adjuster clockwise until it will no longer turn (lightly seat). This is the full hard position.
2. Turn the adjuster counterclockwise 11 – 14 clicks with the punch marks on the adjuster and the shock absorber aligned.

Rear Suspension Adjustments

Rear Suspension Race Sag

Setting the proper race sag (ride height) is very important for competition use.

Race sag refers to the amount of rear wheel travel used by your CRF at rest, ready to ride, with you on the seat. As a general rule of thumb, the race sag dimension should be about one-third of the maximum travel.

On your CRF, ride height is changed by adjusting the rear suspension spring pre-load.

Spring Pre-load & Race Sag Adjustment

The following adjustment procedure establishes the correct starting point for any suspension tuning — the proper rear spring pre-load adjustment for your specific needs.

Your CRF should be at normal racing weight, including fuel and transmission oil. You should be wearing all your normal protective apparel. You will need two helpers.

To calculate the proper adjustment, it is necessary to measure between two fixed points — from the center of the rear fender mounting bolt to the center of the chain adjuster lock nut as illustrated here — for three different situations:

unloaded: motorcycle on workstand with rear suspension fully extended, no rider.

loaded with rider: motorcycle on ground, with rider.

loaded without rider: CRF on ground, without rider.

1. Support your motorcycle on a workstand with the rear wheel off the ground.
2. Measure the *unloaded* dimension.

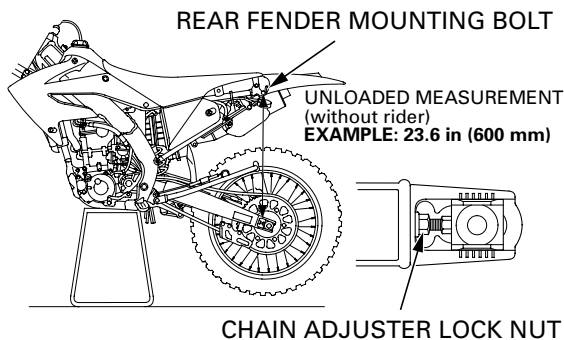

3. Measure the *loaded with rider* dimension. Remove the workstand. With two helpers available, sit as far forward as possible on your CRF's seat, wearing your riding apparel. Ask one helper to steady your CRF perfectly upright so you can put both feet on the pegs. Bounce your weight on the seat a couple of times to help the suspension overcome any situation and settle to a good reference point.

Ask the other helper to measure the *loaded with rider* dimension.

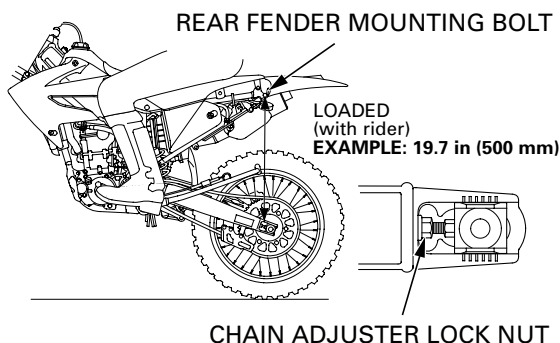

Example:	
Unloaded	= 23.6 in (600 mm)
- Loaded	= 19.7 in (500 mm)
Race Sag	= 3.9 in (100 mm)

4. Calculate the *race sag* dimension. To do this, subtract the *loaded with rider* dimension (step 3) from the *unloaded* dimension (step 2).
Standard Race Sag: 3.9 in (100 mm)

Adjust spring pre-load as necessary to obtain the desired handling results.

Decreasing the race sag dimension (example: 3.5 in, 90 mm) improves turning ability for tight terrain at the cost of slightly reduced straight line stability.

Increasing the race sag dimension (example: 4.3 in, 110 mm) may improve stability on faster terrain with less turns, but will reduce turning performance slightly and may upset the balance between the front and rear suspension, producing a harsher ride. This will happen if the adjustment shifts the effective wheel travel toward the more progressive end of its range.

5. Measure the *loaded without rider* dimension. Do this with your CRF set at the standard race sag.

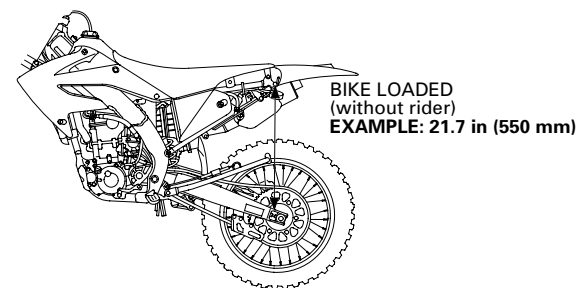

Example:	
Unloaded	= 23.6 in (600 mm)
- Loaded	= 21.7 in (550 mm)
Sag	= 2.0 in (50 mm)
(Without Rider)	

6. Calculate the *free sag* dimension.

To do this, subtract the *loaded without rider* dimension (step 5) from the *unloaded* dimension (step 2).

Free sag indicates the distance your rear suspension should sag from the weight of the sprung portion of your CRF.

With the spring pre-load set to obtain the proper race sag, the rear suspension should sag 0.4 to 1.0 in (10 to 25 mm).

If the rear of your CRF sags less than 0.4 in (10 mm) from its own weight, the spring is too stiff for your weight. It is not compressed enough, even though you have the proper race sag adjustment. As a result, the rear suspension will not extend as far as it should.

Spring Rates

If you are lighter or heavier than the average rider and cannot set the proper ride height without altering the correct spring pre-load, consider an aftermarket shock absorber spring.

A spring that is too soft for your weight forces you to add excessive spring pre-load to get the right race sag and, as a result, the rear end of the motorcycle is raised. This can cause the rear wheel to unload too much in the air and top out as travel rebounds. The rear end may top out from light braking, or kick sideways over lips and square-edged terrain. It may even top-out when you dismount your CRF.

Because of the great absorption quality of the shock bumper rubber, it may be difficult for you to notice when your CRF's suspension is bottoming. Some riders may think the damping or perhaps the leverage ratio is too harsh. In reality, the problem is most likely insufficient spring pre-load or a spring that is too soft. Either situation prevents utilizing the full travel.

Keep in mind that a properly adjusted suspension system may bottom slightly every few minutes at full speed. Adjusting the suspension to avoid this occasional bottoming may cost more in overall suspension performance than it is worth.

A spring that is too stiff for your weight will not allow the rear tire to hook up under acceleration and will pass more bumps on to you.

Suspension Adjustments for Track Conditions

Soft Surface

On soft ground, sand, and especially mud, consider increasing compression damping front and rear.

Sand often requires a bit more rebound damping to minimize rear end kick. Although sand bumps are usually larger, there's more distance between them, giving the shock more time to recover.

You may want a little bit stiffer front suspension for sand tracks to help keep the front end up and improve straight-line stability.

In a muddy event, stiffer aftermarket springs front and rear may help, especially if you are heavier than the average rider. Your CRF may be undersprung because of the added weight of the clinging mud. This additional weight may compress the suspension too much and affect traction.

Hard Surface

For a fast, hard track with no large jumps, you can probably run the same spring as normal, but run softer damping both ways-compression and rebound. If you run softer rebound damping, the wheel will follow the rough ground and small bumps much better, and you will hook up better. With a lot of rebound damping, the wheel returns very slowly and doesn't contact the ground quickly enough after each bump. The result is a loss of traction and slower lap times.

Suspension Adjustment Guidelines

Follow the procedures described below to accurately adjust your CRF, using the methods described on pages 106 – 124. Remember to make all adjustments in one-click increments. Test ride after each adjustment.

Front Suspension Adjustment Adjustments for Type of Track

Hard-surfaced track	Begin with the standard setting. If the suspension is too stiff/soft, adjust according to the chart below.
Sand track	Adjust to a stiffer position. Example: – Turn the compression damping adjuster to a stiffer position. – Install the optional stiff spring. (Adjust compression damping to a softer position and rebound damping to a stiff position at this time.)
Mud track	Adjust to a stiffer position because mud build-up increases your CRF's weight. Example: – Turn the compression damping adjuster to a stiffer setting. – Install the optional stiff spring.

Adjustments for Too Soft/Stiff Damping

	Symptom	Action
Soft suspension	Initial travel too soft: <ul style="list-style-type: none"> • Steering is too quick. • Front end darts while cornering or riding in a straight line. 	<ul style="list-style-type: none"> – Test stiffer compression damping adjustments in one-click increments. – Test stiffer rebound damping in one-click increments.
	Middle travel too soft: <ul style="list-style-type: none"> • Front end dives when cornering. 	If suspension isn't stiff in initial travel: <ul style="list-style-type: none"> – Test stiffer compression damping adjustments in one-click increments. If initial travel becomes stiff because of the above adjustment: <ul style="list-style-type: none"> – Reduce the rebound damping in one-click increments. – Test softer compression damping adjustments in one-click increments. If that doesn't solve the problem, install the optional stiff spring.
	Final travel too soft: <ul style="list-style-type: none"> • Bottoms on landings. • Bottoms on large bumps, especially downhill bumps. 	If initial and middle travel aren't stiff: <ul style="list-style-type: none"> – Test stiffer compression damping adjustments in one-click increments. If initial and middle travel are stiff: <ul style="list-style-type: none"> – Install the optional stiff spring. If initial travel is stiff after installing the optional stiff spring: <ul style="list-style-type: none"> – Test softer compression damping adjustments in one-click increments. If initial travel is still soft after installing the optional stiff spring: <ul style="list-style-type: none"> – Test stiffer compression damping adjustments in one-click increments. If final travel is still soft after installing the optional stiff spring: <ul style="list-style-type: none"> – Increase the fork oil capacity in increments of 0.2 oz (5 cc).
	Entire travel too soft: <ul style="list-style-type: none"> • Front end shakes. • Fork bottoms over any type of terrain. 	<ul style="list-style-type: none"> – Install the optional stiff spring. – Test stiffer compression damping adjustments in one-click increments. – Increase rebound damping in one-click increments.

Suspension Adjustment Guidelines

	Symptom	Action
Stiff suspension	<p>Initial travel too stiff:</p> <ul style="list-style-type: none"> • Stiff on small bumps while riding at full throttle in a straight line. • Stiff on small cornering bumps. • Front end wanders while riding at full throttle in a straight line. 	<ul style="list-style-type: none"> – Test softer compression damping adjustments in one-click increments. – Reduce the rebound damping adjustments in one-click increments. – Check for dirt in the dust seals. Check the fork oil for any contamination. If the front end dives while cornering, reduce the rebound damping in one click increments. If that doesn't solve the problem, install the optional stiff spring. If the stiff spring makes the suspension too stiff over the full range of travel: test softer compression damping adjustments in one-click increments until the desired compression damping for initial travel is obtained.
	<p>Middle travel too stiff:</p> <ul style="list-style-type: none"> • Stiff on bumps when cornering. • Front end wanders when cornering. • Stiff suspension on bumps, especially downhill bumps. • While braking, front end dives during initial travel, then feels stiff. 	<p>If initial travel isn't stiff:</p> <ul style="list-style-type: none"> – Test stiffer compression damping adjustments in one-click increments. (This should produce smooth fork action from initial to middle travel.) <p>If initial and middle travel is stiff:</p> <ul style="list-style-type: none"> – Test softer compression damping adjustments in one-click increments. – Reduce the rebound damping in one-click increments.
	<p>Final travel too stiff:</p> <ul style="list-style-type: none"> • Doesn't bottom on landings, but feels stiff. • Stiff on large bumps, especially downhill bumps. • Stiff on large bumps when cornering. 	<p>If initial and middle travel aren't stiff:</p> <ul style="list-style-type: none"> – Test stiffer compression damping adjustments in one-click increments. (This should produce smooth fork action from initial to middle travel.) <p>If final travel is still stiff after the above adjustment, or if initial and middle travel becomes stiff:</p> <ul style="list-style-type: none"> – Install the optional soft spring. – Test softer compression damping adjustments in one-click increments. <p>If the entire travel feels stiff after the above adjustment:</p> <ul style="list-style-type: none"> – Test softer compression damping adjustments in one-click increments until the desired initial travel compression damping is obtained. – Lower the oil capacity by 0.2 oz (5 cc).
	<p>Entire travel too stiff:</p> <ul style="list-style-type: none"> • Stiff suspension on any type of terrain. 	<ul style="list-style-type: none"> – Test softer compression damping adjustments in one-click increments. – Reduce the rebound damping in one-click increments. – Lower the oil capacity by 0.2 oz (5 cc).

Suspension Adjustment Guidelines

Rear Suspension Adjustment Adjustments for Type of Track

Hard-surfaced track	Begin with the standard settings. If the suspension is too stiff/soft, adjust according to the chart below.
Sand track	Lower the rear end (to improve front wheel stability) by increasing Race Sag (reduce spring pre-load). Example: – Turn the compression damping adjuster and, especially, rebound damping adjuster to a stiffer setting. – Increase standard Race Sag (+0.2 to 0.4 in/5 to 10 mm).
Mud track	Adjust to a stiffer position because mud build-up increases your CRF's weight. Example: – Adjust the compression and rebound damping adjusters to stiffer settings. – Install the optional stiff spring. – Reduce standard Race Sag (–0.2 to 0.4 in/–5 to 10 mm).

Symptoms and Adjustment

- Always begin with the standard settings.
- Turn the low speed compression and rebound adjusters in one-click increments, and the high speed compression adjuster in 1/6 turn increments at a time. Adjusting two or more clicks or turns at a time may cause you to pass over the best adjustment. Test ride after each adjustment.
- If, after setting, the suspension feels unusual, find the corresponding symptom in the table and test stiffer or softer compression and/or rebound damping adjustments until the correct settings are obtained as described.

	Symptom	Action
Stiff suspension	Suspension feels stiff on small bumps	1. Test softer low speed compression adjustment. 2. If it still feels stiff, further test softer low and high speed compression adjustments simultaneously.
	Suspension feels stiff on large bumps	1. Test softer high speed compression adjustment. 2. If it still feels stiff, further test softer low and high speed compression adjustments simultaneously.
	Entire travel too stiff	1. Test softer high and low speed compression adjustments and rebound adjustment simultaneously. 2. If it still feels stiff, replace the spring with a softer spring (optional) and begin with the standard settings to softer settings.
Soft suspension	Entire travel too soft	1. Test stiffer high and low speed compression adjustments simultaneously. 2. If it still feels soft, replace the spring with a stiffer spring (optional) and begin with the standard settings to stiffer setting.
	Rear end sways	1. Test stiffer high and low speed compression adjustments and rebound adjustment to stiffer settings simultaneously.
Suspension bottoms	Suspension bottoms at landing after jumping	1. Test stiffer high speed compression adjustment. 2. If it still bottoms, test stiffer high and low speed compression adjustments, and replace the spring with a stiffer spring (optional) if necessary.
	Suspension bottoms after landing	1. Test stiffer low speed compression adjustment. 2. If it still bottoms, test stiffer high and low speed compression adjustments, and replace the spring with a stiffer spring (optional) if necessary.
	Suspension bottoms after end of continuous bumps	1. Test softer rebound damping adjustment. 2. If it still bottoms, test stiffer high and low speed compression adjustments and softer rebound damping adjustment, and replace the spring with a stiffer spring (optional) if necessary.

Carburetor Adjustment & Tuning Tips

The carburetor used on your CRF will seldom experience trouble with the standard settings under average load, and average climatic and barometric conditions. However, to fine-tune the engine's power output, the carburetor may require specific adjustments for competition use. However, in order to comply with emission regulations, we recommend that you make no carburetor changes unless you use your CRF for competition only.

Carburetor Components

Cold Start Circuit

A very rich mixture must be delivered to the cylinder when a cold engine is being started. When the choke knob (1) is pulled out, fuel is metered by the starter jet (2) and is mixed with air from the air passage (3) (located above the throttle valve (4)) to provide a rich mixture for starting. The mixture discharges through the orifice (5) into the cylinder.

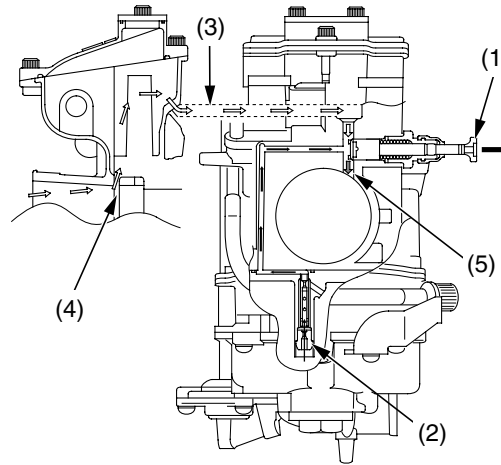

- (1) choke knob
- (2) starter jet
- (3) air passage
- (4) throttle valve
- (5) orifice

Hot Start Circuit

A lean mixture must be delivered to the cylinder when a hot engine is being started. When the hot start lever is pulled back, the hot start valve (1) opens, allowing air to be supplied to the main bore (2) through the hot start air passage (3). This extra air enters the air-fuel mixture from the slow circuit resulting in a lean condition.

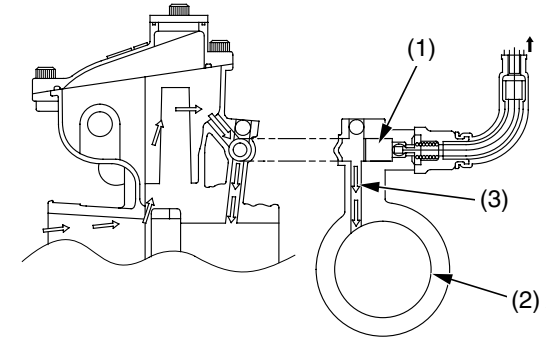

- (1) hot start valve
- (2) main bore
- (3) hot start air passage

Carburetor Adjustment & Tuning Tips

Accelerator Pump Circuit

The accelerator pump circuit operates when the throttle is opened. As the throttle valve (1) opens, the pump rod (2) depresses the diaphragm (3). At this time, the inlet check valve (4) is shut resulting in a sharp increase in pressure in the pump chamber (5). The outlet check valve (6) then opens, supplying fuel to the main bore via the accelerator nozzle (7).

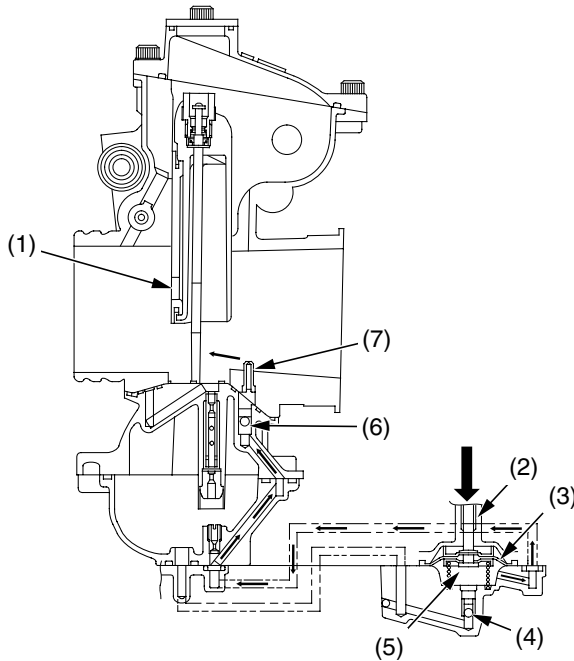

- (1) throttle valve
- (2) pump rod
- (3) diaphragm
- (4) inlet check valve
- (5) pump chamber
- (6) outlet check valve
- (7) accelerator nozzle

Slow Circuit

Fuel is metered by the slow jet (1) and mixed with air from the air passage (2). The mixture enters the venturi through the bypass (3) and pilot outlet (4) that has been metered by the pilot screw (5).

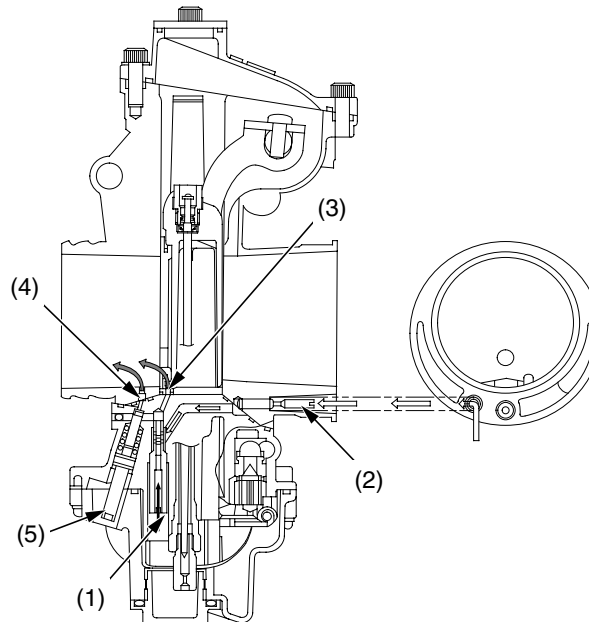

- (1) slow jet
- (2) air passage
- (3) bypass
- (4) pilot outlet
- (5) pilot screw

Main Circuit

Fuel is metered by the main jet (1), jet needle (2) and needle jet (3). It is then mixed with air coming from the air jet (4) and enters the venturi past the needle jet.

Baffle Plate

The baffle plate (5) prevents foaming of fuel or abnormal fuel level around the main jet.

Float Bowl

The float (6) and float valve (7) operate to maintain a constant level of fuel in the float bowl.

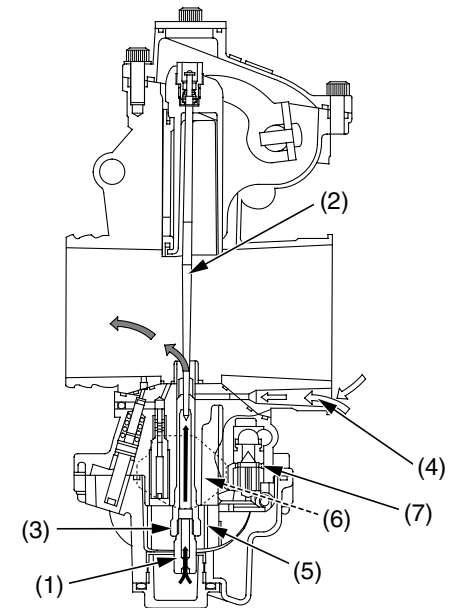

- (1) main jet
- (2) jet needle
- (3) needle jet
- (4) air jet
- (5) baffle plate
- (6) float
- (7) float valve

Carburetor Adjustment & Tuning Tips

Carburetor Removal

1. Turn the fuel valve OFF.
2. Drain the remaining fuel in the float bowl by loosening the carburetor drain screw (1).

▲ WARNING

Gasoline is highly flammable and explosive. You can be burned or seriously injured when handling fuel.

- Stop the engine and keep heat, sparks and flame away.
- Handle fuel only outdoors.
- Wipe up spills immediately.

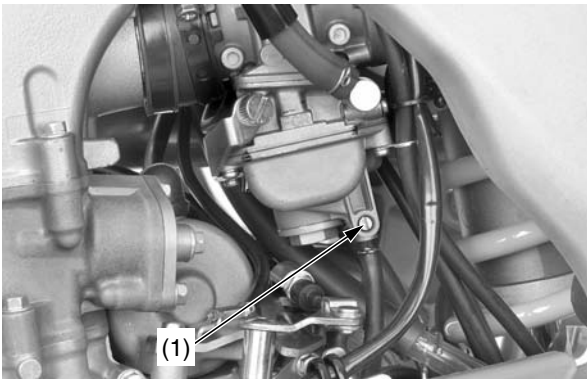

(1) carburetor drain screw

3. Tighten the carburetor drain screw after drain the fuel.

4. Remove the fuel tank (page 37).
5. Remove the band (2) and rear suspension upper mounting nut (3), and pull out the rear suspension upper mounting bolt (4).

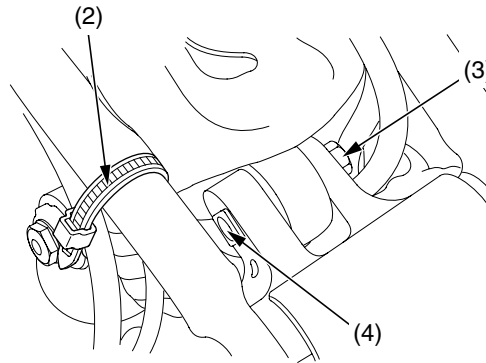

- (2) band
(3) rear suspension upper mounting nut
(4) rear suspension upper mounting bolt

6. Lift the subframe to the upright position (page 39).
7. Loosen the intake band screw (5).

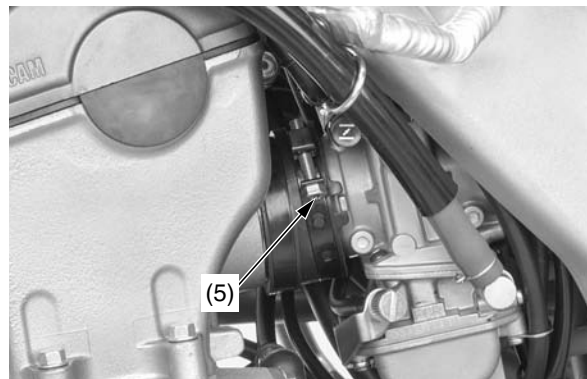

(5) intake band screw

8. Disconnect the throttle position sensor connector (6). Remove the carburetor.

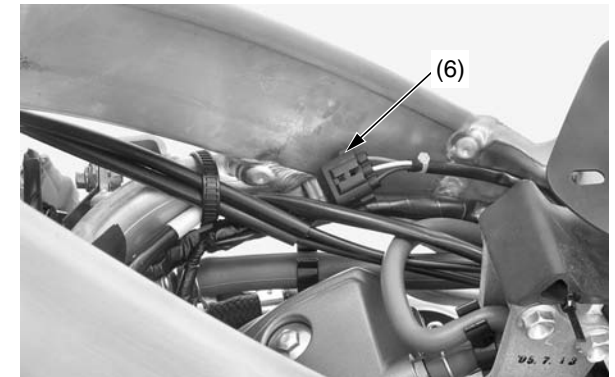

(6) throttle position sensor connector

9. Remove the hot start cable holder (7).

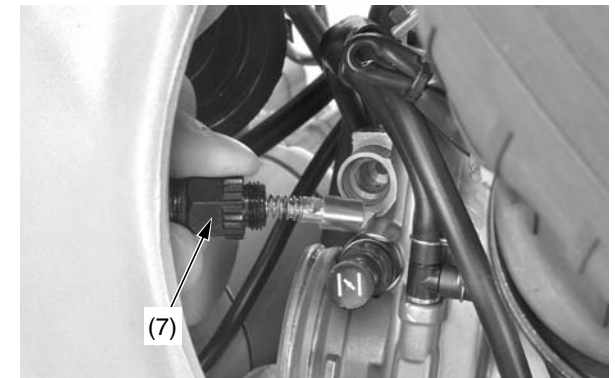

(7) hot start cable holder

10. Remove the throttle drum cover bolt (8) and throttle drum cover (9).

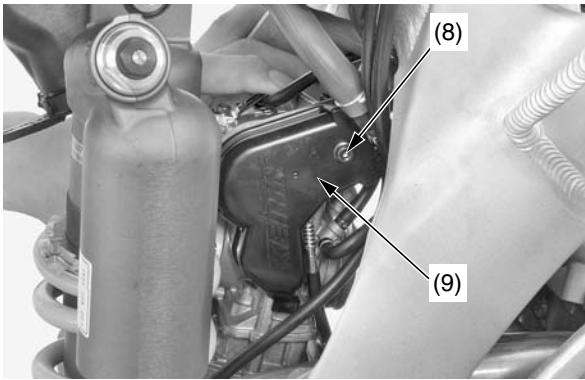

(8) throttle drum cover bolt
(9) throttle drum cover

11. Remove the throttle cables (10) by loosening the throttle cable lock nut (11) and adjusting nuts (12).

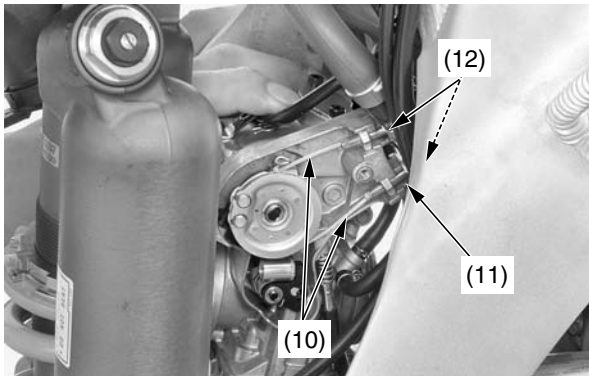

(10) throttle cables
(11) throttle cable lock nut
(12) adjusting nuts

Carburetor Disassembly

1. Pull up the cable clamp (1) and remove the carburetor top cover bolts (2). Then remove the carburetor top cover (3).

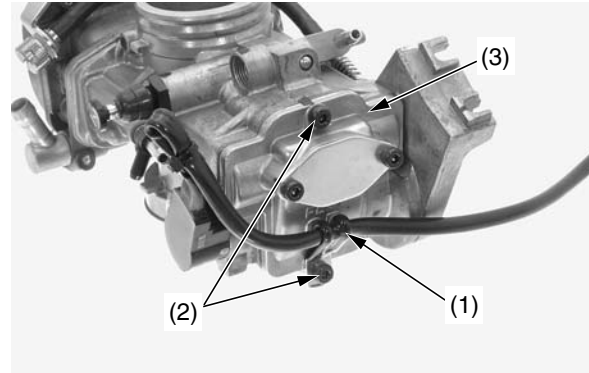

(1) cable clamp
(2) carburetor top cover bolts
(3) carburetor top cover

2. Remove the jet needle/holder assembly (4) from the throttle valve (5).

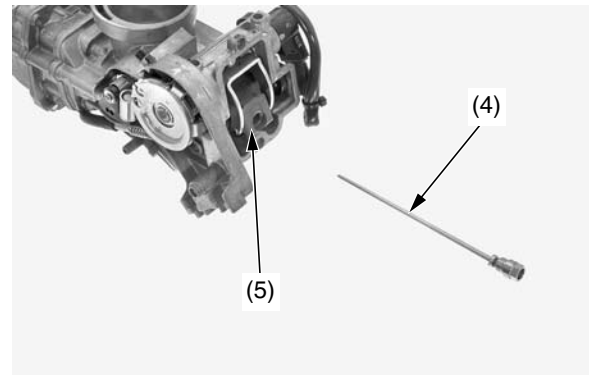

(4) jet needle/holder assembly
(5) throttle valve

3. Remove the link arm set torx screw (6). When installing the link arm set torx screw, apply a locking agent to the link arm set torx screw threads.
4. Remove the throttle valve (7), throttle valve roller (8) and floating valve (9).

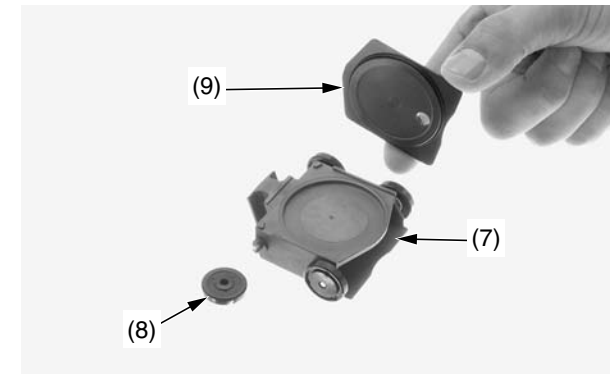
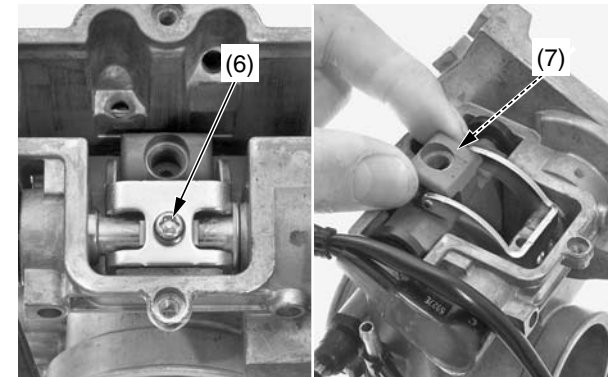

(6) link arm set torx screw
(7) throttle valve
(8) throttle valve roller
(9) floating valve

(cont'd)

Carburetor Adjustment & Tuning Tips

When installing the floating valve (9) onto the throttle valve (7) make sure the floating valve's flat side faces out and the hole (10) faces down.

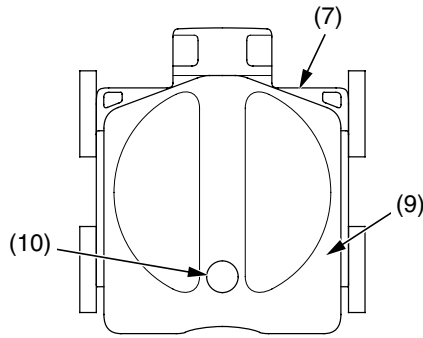

(7) throttle valve
(9) floating valve
(10) hole

5. Remove the accelerator pump cover screws (11) and accelerator pump cover (12).

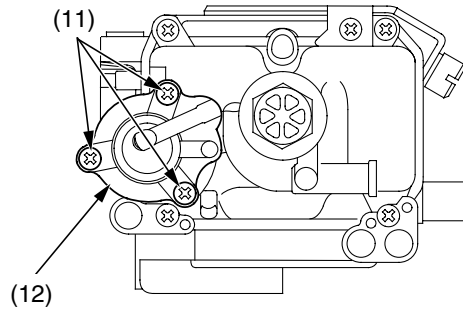

(11) accelerator pump cover screws
(12) accelerator pump cover

6. Remove the U-ring (13), O-ring (14), spring (15) and diaphragm (16).
Clean the diaphragm.
When installing the U-ring into the accelerator pump cover (12) make sure the U-ring's flatside faces down, away from the float bowl (17).

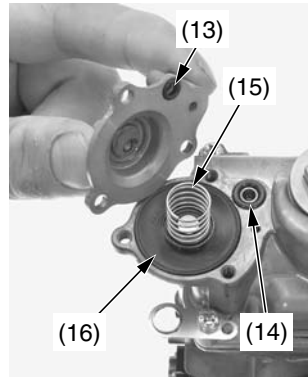

(12) accelerator pump cover
(13) U-ring
(14) O-ring

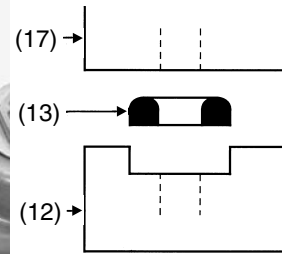

(15) spring
(16) diaphragm
(17) float bowl

7. Remove the holder screw (18), throttle stop screw holder (19), float bowl screws (20), tube guides (21) and float bowl (17).

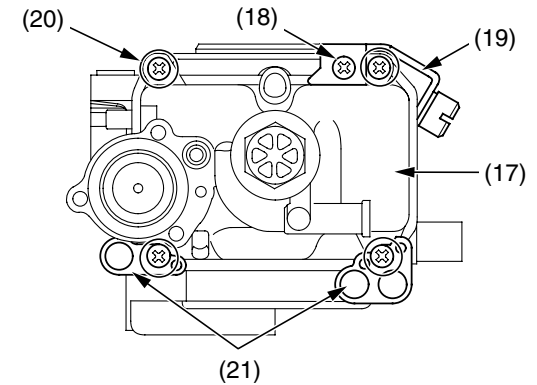

(17) float bowl
(18) holder screw
(19) throttle stop screw holder
(20) float bowl screws
(21) tube guides

8. Remove the pump rod (22).
Clean the pump rod and rod passage (23).
Install the pump rod into the link lever (24).
Push the rod forcibly into the link lever until it snaps into place.

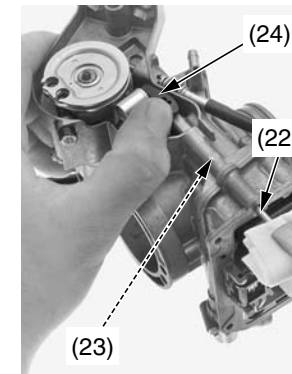

(22) pump rod
(23) rod passage

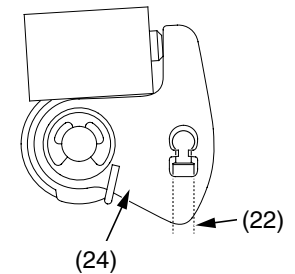

(24) link lever

9. Measure the float level (25) with the float level gauge (26) while the float tab is just contacting the float valve with the carburetor intake (27) facing up. The float level should be 0.31 in (8.0 mm).
If the float level is out of specification, adjust it by bending the float tab carefully.

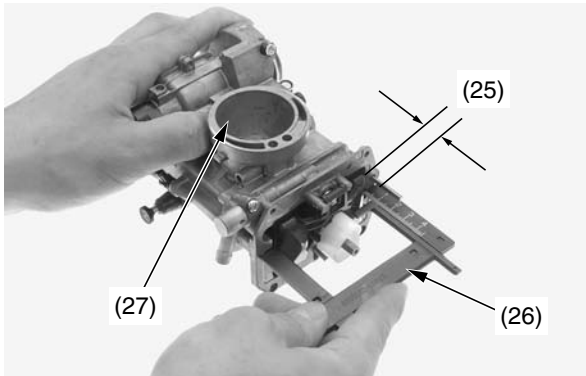

(25) float level
(26) float level gauge
(27) carburetor intake

10. Remove the leak jet (28) from the float bowl (17).
Clean the leak jet.

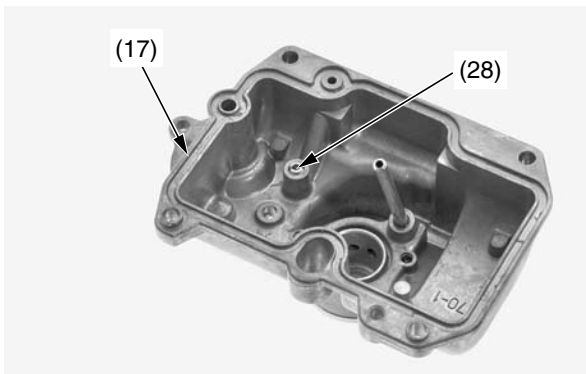

(17) float bowl (28) leak jet

Carburetor Assembly

To assemble, reverse the disassembly procedures.
To install the carburetor, reverse the removal procedures.

Tighten the following parts to the specified torque.

- float bowl screws:
1.5 lbf-ft (2.1 N·m, 0.2 kgf-m)
- accelerator pump cover screws:
1.5 lbf-ft (2.1 N·m, 0.2 kgf-m)
- carburetor top cover bolts:
1.5 lbf-ft (2.1 N·m, 0.2 kgf-m)
- jet needle/holder assembly:
1.5 lbf-ft (2.1 N·m, 0.2 kgf-m)
- leak jet:
0.2 lbf-ft (0.3 N·m, 0.03 kgf-m)
- rink arm set torx screw:
1.5 lbf-ft (2.1 N·m, 0.2 kgf-m)
- throttle drum cover bolt:
2.5 lbf-ft (3.4 N·m, 0.3 kgf-m)
- hot start cable nut:
1.5 lbf-ft (2.1 N·m, 0.2 kgf-m)
- throttle cable lock nut:
3.0 lbf-ft (4 N·m, 0.4 kgf-m)
- throttle cable bolt:
3.0 lbf-ft (4 N·m, 0.4 kgf-m)
- shock absorber upper mounting nut:
32 lbf-ft (44 N·m, 4.5 kgf-m)

- Route the throttle cables (1), hot start cable (2) and throttle sensor wire correctly.
- After installing the carburetor, adjust the throttle cable freeplay and hot start cable freeplay.
- After installing the carburetor, check the throttle position sensor connector (3) for correct routing.
- After installing the carburetor, check the air vent hoses (4) and overflow hose (5) for kinking or pinching and correct routing.

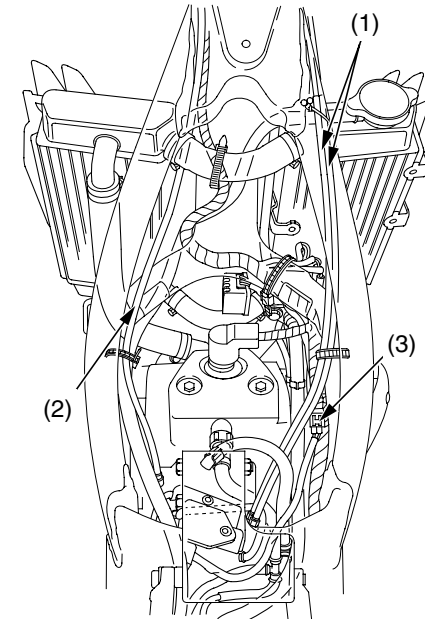

(1) throttle cables
(2) hot start cable
(3) throttle position sensor connector

Carburetor Adjustment & Tuning Tips

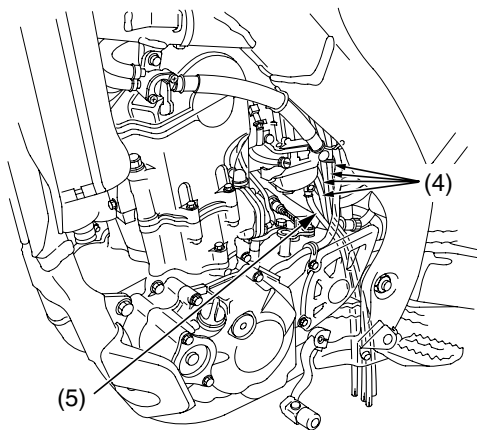
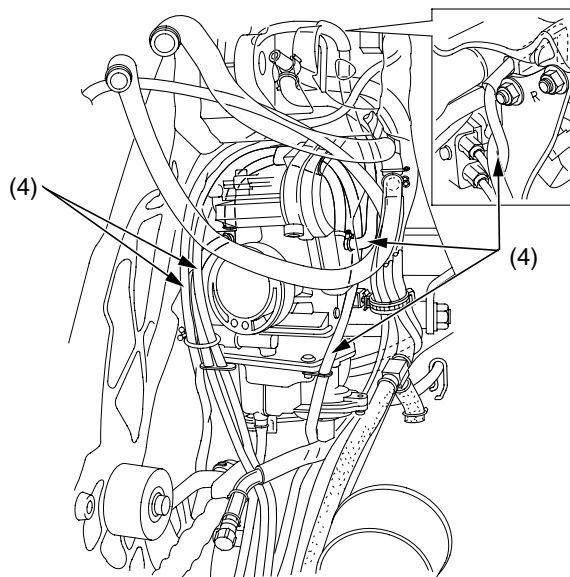

- (4) air vent hoses
- (5) overflow hose

Idle Speed Adjustment

1. If the engine is cold, start it and warm it up 3 minutes and then shut it off.
2. Connect a tachometer to the engine.
3. Shift into neutral. Start the engine.
4. Keep the motorcycle in an upright position.
5. Adjust idle speed with the throttle stop screw (1).

Idle speed:
1,700 ± 100 rpm

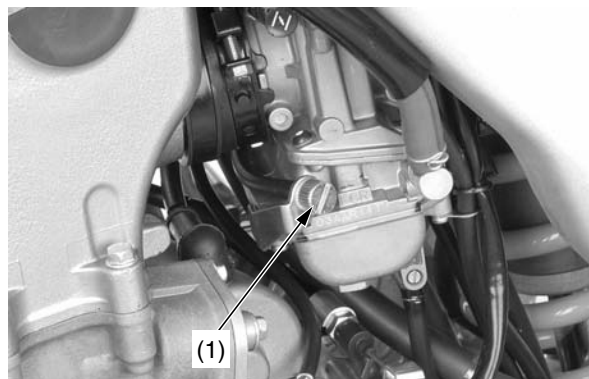

(1) throttle stop screw

The following suggestions may improve a specific concern. Subtle changes in overall handling may also be noted.

Rear End

If you have a problem with rear wheel traction, raise the rear end of your CRF by increasing the rear spring pre-load. Instead of running 3.9 in (100 mm) of sag, you can run 3.5 in (90 mm) so the rear of the bike will sit a little higher. This should produce more traction because of the change to the swingarm and the location of your CRF's center of gravity.

If you have a problem with the steering head shaking when you use the front brake hard or if your CRF wants to turn too quickly, lower the rear of the motorcycle by reducing the rear spring pre-load. This will increase fork rake and trail and should improve stability in a straight line. The effective suspension travel will be transferred toward the firmer end of wheel travel.

Keep the race sag adjustment (page 122) in the 3.5 – 4.3 in (90 – 110 mm) range.

Fork Height/Angle

Standard Position

The position of the outer tubes in the clamps is not adjustable. Align the top of the outer tube (1) with the top of the upper fork clamp (2).

(STANDARD POSITION)

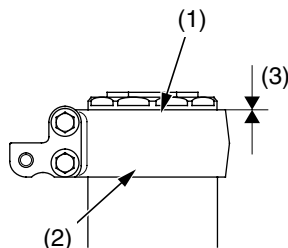

- (1) top of outer tube
- (2) upper fork clamp
- (3) standard position
0 in (0 mm)

Wheelbase

Adjusting your CRF's wheelbase can offer subtle changes in overall handling. You may adjust wheelbase by adding or removing links on the drive chain. If you change the wheelbase, be sure to re-check race sag and adjust, if necessary.

In the past, a general rule was lengthen the wheelbase to add straight line stability, shorten the wheelbase to improve turning. However, we suggest you do not lengthen the wheelbase of your CRF unless you are racing on a track with more fast sections than normal.

As a general recommendation, keep the wheelbase as short as possible. This positions the wheels closer together, improves turning response, increase weighting (traction) on the rear wheel, and lightens weighting on the front wheel.

With your CRF, you will probably find that the standard setting or a shorter wheelbase will offer more overall benefits.

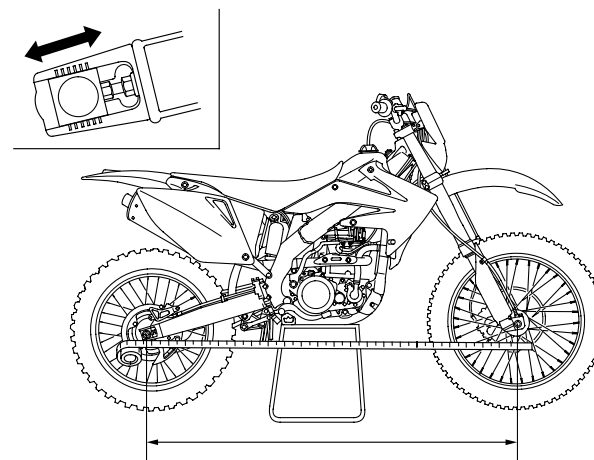

Gearing

You can “adjust” the power delivery of the standard engine to suit track conditions by changing gearing. This allows you to utilize a different portion of the engine’s power range at a given throttle setting. New gearing may provide the change you are looking for without the need to consider further modifications.

The portion of your engine’s power range you use can be adjusted by changing the final drive ratio with different sized driven sprockets. Gearing changes allow you to more closely match the type of terrain and the available traction. Normally, a change of one tooth on the rear sprocket will be sufficient.

There is a choice of both higher and lower final drive ratios with two optional aluminum driven sprockets. Like the optional springs and these sprockets are listed in the *Optional Parts List* section (page 163) of this manual.

Unless you have the required mechanical knowhow, tools, and a Honda Service Manual, sprocket changing should be done by your Honda dealer.

Higher Gearing (less driven sprocket teeth)

- increases top speed in each gear (provided the engine will pull the higher gearing)
- reduces frequency of shifting (wider gear ratios)
- reduces engine rpm at a given throttle setting or ground speed (which may allow better rear wheel traction on slippery or loose terrain)

However:

- the engine may not pull the higher gearing
- the spacing between gears may be too wide
- engine rpm may be too low

Lower Gearing (more rear sprocket teeth)

- decrease top speed in each gear
- increases frequency of shifting (narrower gear ratios)
- increases engine rpm at a given throttle setting or ground speed (which may provide more power-to-the-ground on good traction surfaces)

However:

- spacing between gears may be too narrow
- engine rpm may be too high

Some tracks may be watered heavily prior to the first race, then lightly or not at all during the day. This results in a track surface that is slippery during the first few races, then changes from good to great and back to good and possibly ends the day with a slick rock-hard consistency. Ideally, your gearing should be adjusted to suit all these conditions.

- Wet and slippery or sandy conditions: use a higher gear (less teeth) to keep engine rpm down, and avoid unwanted wheelspin. The engine may bog in certain corners so you’ll need to slip the clutch to compensate; downshifting may be too drastic a change in speed.
- Average conditions: use the standard sprocket.
- Hard (but not slippery) track conditions: use lower gearing (more teeth) to keep the engine rpm high where the engine produces the most power. This may require an extra upshift on certain sections or perhaps you can just rev it out a bit longer.

For tight tracks, consider lower gearing to avoid having to slip the clutch frequently. Repeated fanning or pulling of the clutch lever in a turn to raise engine rpm may eventually damage the clutch system.

A gearing change may help for riding in sand, where you want to keep the front end light so it can float from the peak of one sand whoop to the next. Generally, with higher gearing, it is easier to maintain that perfect attitude (maximum rear wheel traction and a light front end) because you remain in the powerband longer in each gear. The higher gearing allows you to steer more efficiently with throttle control and body English.

If you are riding a track with sections where you choose to over-rev the engine temporarily rather than shifting up, higher gearing might help.

Sometimes you have to sacrifice performance on one section of the track to gain a better overall time. Your goal is the fastest overall lap time, even if the cost is some sections where the gearing feels wrong.

If you decide to try a gearing change, have someone check your times with a stopwatch (before and after the change) to get an accurate appraisal of the change. “Seat-of-the-pants” feelings can’t be trusted. Eliminating wheelspin with a gearing change can make you feel like you’re going slower when, in reality, you’ve decreased your time by increasing your speed with better traction.

These gearing recommendations should be evaluated by considering your ability, your riding style, and the track.

Choosing the correct tire tread pattern and rubber compound can affect your placing in competition. The tires on your CRF offer a “happy medium” for the variety of soil conditions the majority of riders are likely to encounter.

Experienced competitors often switch to tires developed for specific terrain conditions. If you do switch, stay with the factory recommended sizes. Other tires may affect handling or acceleration.

Be aware that tire sizes (width and aspect ratio) do vary from manufacturer to manufacturer or even among tires made by the same manufacturer. Variations in tires, especially the sidewall profile, can change the attitude of your CRF and its handling. Tire variations that raise or lower the rear of your CRF have a more significant effect on handling than variations in front tires which, generally, don’t vary as much. Often, you can see or feel the change in tire size. Another way to check is to measure the rolling circumference of the old and new tires. A higher profile tire will have a larger rolling circumference.

If you do switch to tires designed for special terrain use, remember they will be less acceptable in other circumstances. For example, an aggressive mud tire will give excellent grip on wet, loamy terrain, but less impressive grip on a hard surface.

If you choose a tire with a sticky compound for added traction, remember that it may transfer additional loads to the transmission because it grips so well, especially when riding in situations that normally place unusual demands on the transmission.

Complete consumer information can be obtained from the various tire manufacturer representatives and dealers.

Some general recommendations for specific terrain follow:

Hard, Slick Soil

Use tires with many relatively short knobs that are close together in order to obtain the largest possible contact patch on the surface. The rubber compound needs to be softer for hard ground in order to hook up, but not so soft that the knobs roll over easily and affect holding a straight line. These tires tend to wear more quickly than standard tires because of the combination of soft rubber and hard terrain.

Muddy Soil

Use a more open tread pattern to avoid clogging. For these conditions, the relatively long knobs will probably be made from a harder rubber compound to reduce any tendency to bend back under acceleration or wear quickly.

Loose, Sandy Soil

Use a tire that is similar in construction to those needed for tacky soil and mud, but with a few more knobs.

Personal Fit Adjustments

The following suggestions may make your ride both more comfortable and more responsive to your control input.

Control Positioning

- Position the control levers so that you can use them comfortably when seated and standing.
- Adjust the mounting bolt torque of the clutch and front brake lever assemblies so that they can rotate on the handlebar in a fall. If an assembly does not rotate, it may bend or break a control lever. Make sure that the bolts are torqued securely enough to prevent slippage during normal operation.

Apply Pro Honda Hondalock or an equivalent to the threads of these bolts prior to adjustment to help ensure the correct torque is retained. Tighten the top bolts first.

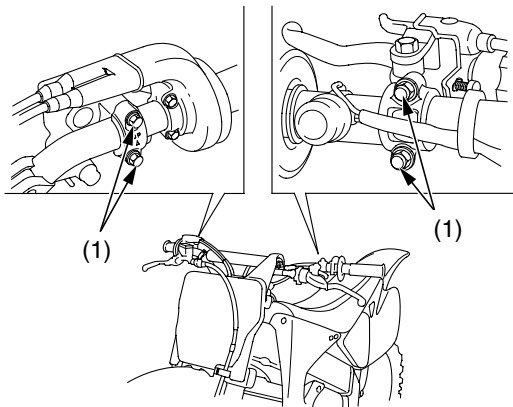

(1) control lever mounting bolts

As an alternative, consider wrapping the handlebar area under the control assemblies with teflon tape. Then tighten the assemblies to their normal torque. Upon impact, the fully-tightened assemblies should rotate on the Teflon tape.

- Position the shift lever and rear brake pedal so they are close to your boot for rapid access, but not so close that either is depressed when sitting or standing comfortably on your CRF.

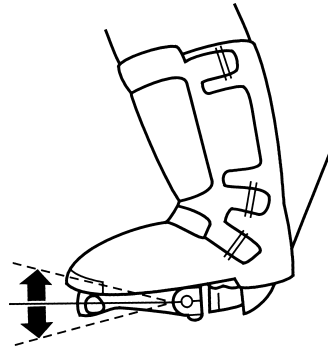

Handlebar Position, Width & Shape

- Position the handlebar so that both gripping the bar and operating the controls is comfortable while both seated and standing, while riding straight ahead and turning. Tighten the forward bolts first.
- The handlebar position may be moved forward either 3 mm (using optional handlebar lower holders) or 6 mm (by rotating the standard holders 180 degrees). Refer to the Service Manual for installation instructions. Be sure to check control cable and wiring harness routing after the adjustment.

- Handlebar width can be trimmed with a hacksaw to better suit your particular shoulder width and riding preference. Think this through carefully and cut off just a small amount at a time from both sides equally. It is obviously much easier to make the handlebar narrower than it is to add material.

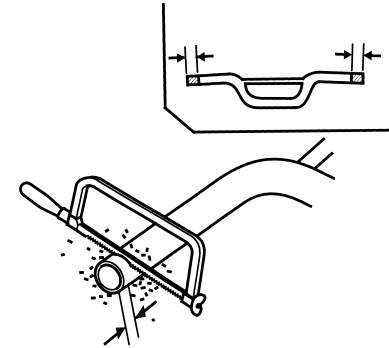

- Chamfer the edges to remove burrs and other irregularities or roughness after sawing the handlebar.
- An alternate handlebar shape, through varying rise or rearward sweep dimensions, will provide further adjustment to riding position and may better suit your particular body size or riding style. Each of the ergonomic dimensions of the machine were determined to suit the greatest possible number of riders based on an average size rider.

Here's helpful advice on how to transport and store your Honda, as well as three troubleshooting flow charts.

Transporting Your Motorcycle140
Storing Your Honda.....141
You & the Environment143
Troubleshooting.....144

Transporting Your Motorcycle

If you use a truck or motorcycle trailer to transport your Honda, we recommend that you follow these guidelines:

- Use a loading ramp.
- Make sure the fuel valve is off.
- Secure the motorcycle in an upright position, using motorcycle tie-down straps. Avoid using rope, which can loosen and allow the motorcycle to fall over.

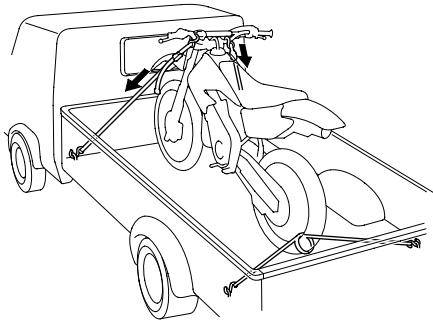

To secure your CRF, brace the front wheel against the front of the truck bed or trailer rail. Attach the lower ends of two straps to the tie-down hooks on your CRF. Attach to the upper ends of the straps to the handlebar (one on the right side, the other on the left), close to the fork.

Check that the tie-down straps do not contact any control cables or electrical wiring.

Tighten both straps until the front suspension is compressed about half-way. Too much pressure is unnecessary and could damage the fork seals.

Use another tie-down strap to keep the rear of the motorcycle from moving.

We recommend that you do not transport your CRF on its side. This can damage the motorcycle, and leaking gasoline could be a hazard.

If you won't be riding for an extended period, such as during the winter, thoroughly inspect your Honda and correct any problem before storing it. That way, needed repairs won't be forgotten and it will be easier to get your CRF running again.

To reduce or prevent deterioration that can occur during storage, also follow the following procedures.

Preparation for Storage

1. Completely clean all parts of your CRF. If your CRF has been exposed to sea air or salt water, wash it down with fresh water and wipe dry.
2. Change the engine oil and filter (page 44).
3. Change the transmission oil (page 47).
4. Drain the fuel tank and carburetor into an approved gasoline container. Turn the fuel valve OFF and loosen the carburetor drain screw. Drain gasoline into an approved container. Tighten the carburetor drain screw to the specified torque:
1.1 lbf-ft (1.5 N·m, 0.2 kgf-m)

⚠ WARNING

Gasoline is highly flammable and explosive. You can be burned or seriously injured when handling fuel.

- Stop the engine and keep heat, sparks and flame away.
- Handle fuel only outdoors.
- Wipe up spills immediately.

5. Remove the radiator cap and coolant drain bolt (1) at the water pump (2) to drain coolant. After the coolant has been completely drained, reinstall the coolant drain bolt with a new sealing washer and radiator cap. Coolant drain bolt:
7 lbf-ft (10 N·m, 1.0 kgf-m)

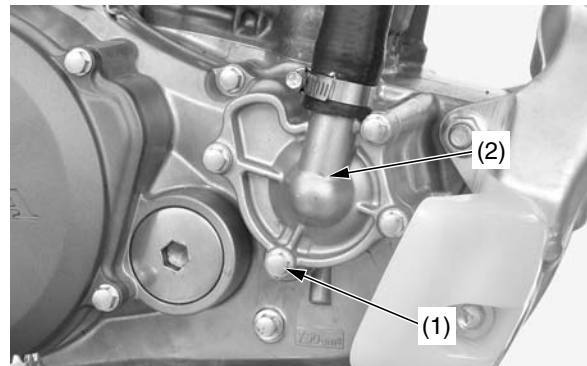

(1) coolant drain bolt (2) water pump

6. Disconnect the siphon tube from the radiator. Drain the reserve tank coolant. Empty the coolant and rinse the inside of the reserve tank with water.
7. Lubricate the drive chain.
8. Remove the battery and charge it fully. Store in an area protected from freezing temperatures and direct sunlight. Slow charge the battery (page 100) once a month.

9. Inflate the tires to their recommended pressures.
10. Place your CRF on the optional Honda workstand or equivalent to raise both tires off the ground.
11. Stuff a rag into the muffler outlet. Then tie a plastic bag over the end of the muffler to prevent moisture from entering.
12. Store your CRF in an unheated area, free of dampness, away from sunlight, with a minimum of daily temperature variation.
13. Cover your CRF with a porous material. Avoid using plastic or similar non-breathing, coated materials that restrict air flow and allow heat and moisture to accumulate.

Storing Your Honda

Removal from Storage

1. Uncover and clean your CRF.
Change the engine and transmission oil if more than 4 months have passed since the start of storage.
2. Uncover the end of the muffler and remove the rag from the muffler outlet.
3. Fill the fuel tank with recommended fuel (page 41).
4. Charge the battery (page 100) as required. Install the battery.
5. Pour a fresh recommended coolant mixture (page 48) slowly into the radiator filler hole up to the filler neck.
Capacity:
1.27 US qt (1.20 ℓ)
at disassembly
1.19 US qt (1.13 ℓ)
at draining

Remove the radiator reserve tank cap and fill the reserve tank to the upper level line.
Bleed air from the system.
6. Perform all maintenance checks (page 11).

Owning and riding a motorcycle can be enjoyable, but you must do your part to protect nature. When you show respect for the land, wildlife, and other people, you also help preserve the sport of off-road riding.

Following are tips on how you can be an environmentally-responsible motorcycle owner.

- **Choose Sensible Cleaners.** Use a biodegradable detergent when you wash your CRF. Avoid aerosol spray cleaners that contain chlorofluorocarbons (CFCs) which damage the atmosphere's protective ozone layer. Don't throw cleaning solvents away; see the following guidelines for proper disposal.
- **Recycle Wastes.** It's illegal and thoughtless to put used engine oil in the trash, down a drain, or on the ground. Used oil, gasoline, and cleaning solvents contain poisons that can hurt refuse workers and contaminate our drinking water, lakes, rivers, and oceans. Before changing your oil, make sure you have the proper containers. Put oil and other toxic wastes in separate sealed containers and take them to a recycling center. Call your local or state office of public works or environmental services to find a recycling center in your area and get instructions on how to dispose of non-recyclable wastes.

NOTICE

Improper disposal of drained fluids is harmful to the environment.

Troubleshooting

The items that are serviceable using this Manual are followed by the page number reference in parenthesis. The items that require use of the Honda Service Manual are followed by an asterisk (*).

ENGINE DOES NOT START OR IS HAND TO START

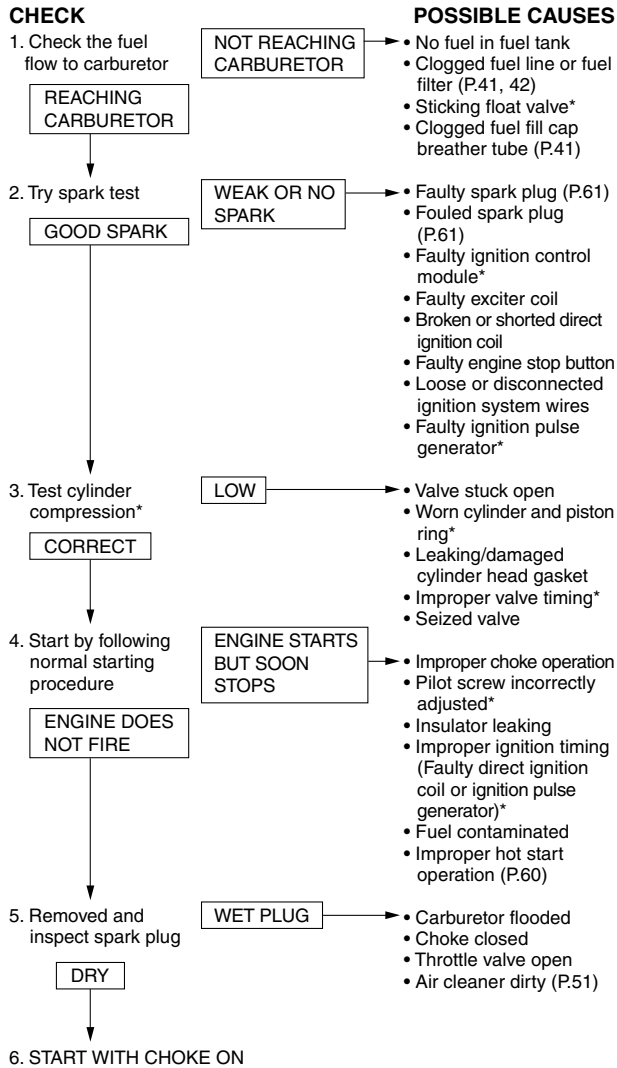

POOR PERFORMANCE AT LOW AND UNSTABLE IDLE SPEED

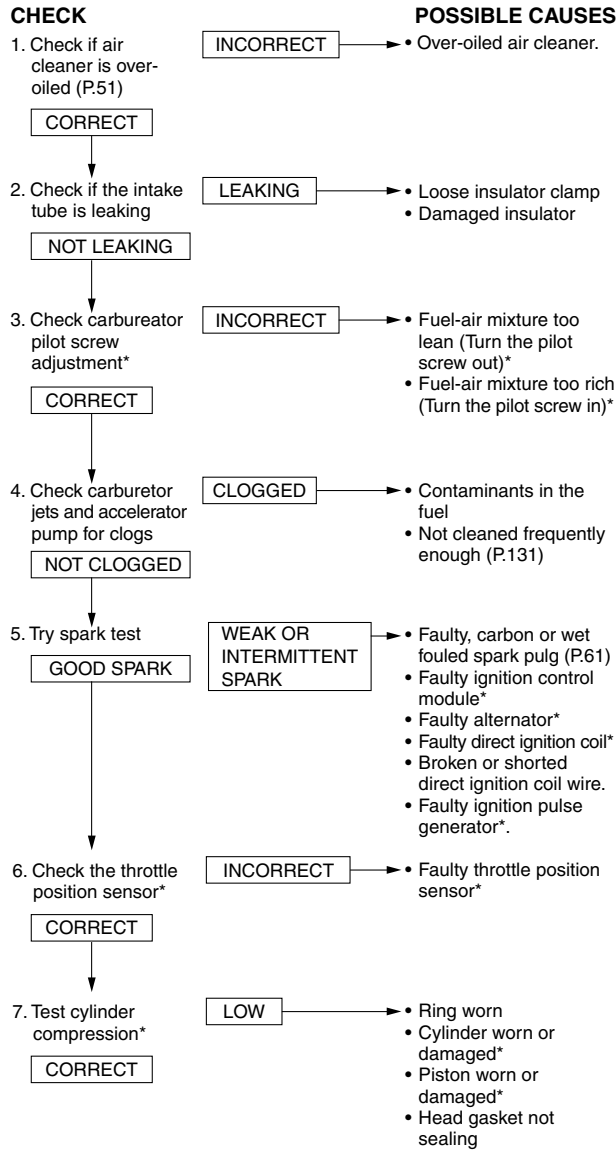

POOR PERFORMANCE AT HIGH SPEED

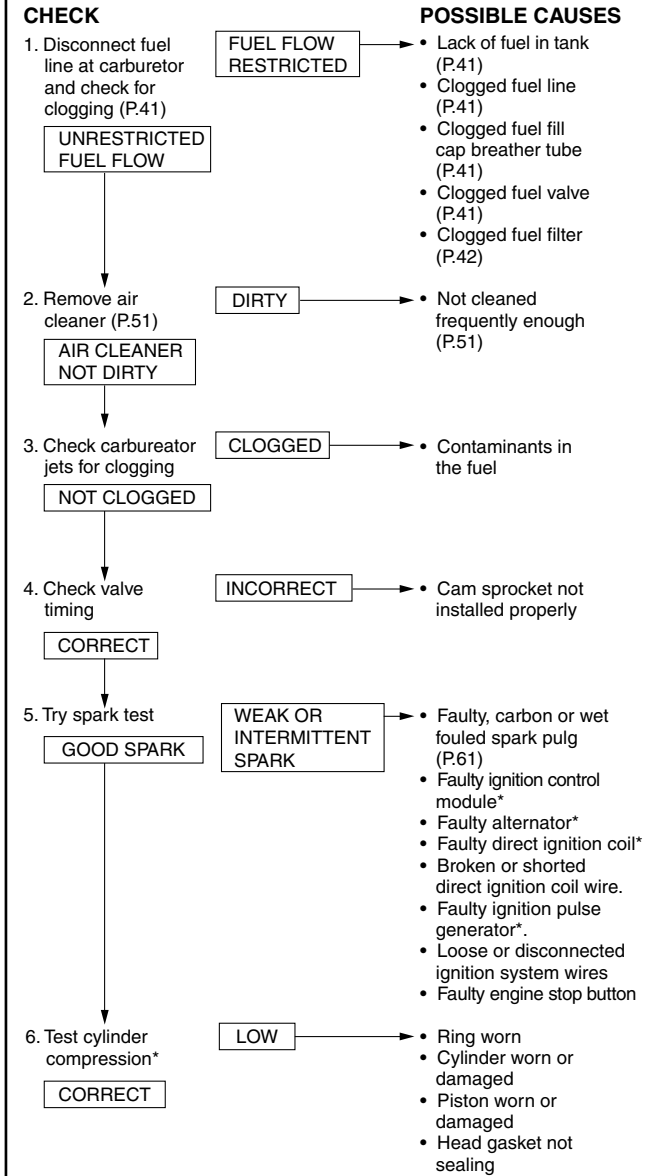

This section gives practical advice to help you problems.

If a Fuse Blows146
If Your Battery Is Low (or Dead).....147

If a Fuse Blows

All of the electrical circuits on your CRF have a fuse to protect them from damage caused by excess current flow (short circuit or overload).

If something electrical on your CRF stops working, the first thing you should check for is a blown fuse. Check the fuse before looking elsewhere for another possible cause of the problem. Replace a blown fuse and check component operation.

- The main fuse (and spare) are located on the starter magnetic switch behind the right side cover.

Recommended Main Fuse: 15A

1. To prevent an accidental short circuit, stop the engine.
2. Remove the seat mounting bolt (1), right side cover bolt (2), collar (3) and right side cover (4).

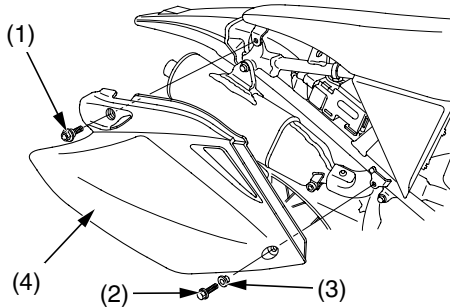

- (1) seat mounting bolt
- (2) right side cover bolt
- (3) collar
- (4) right side cover

3. Disconnect the wire connector (5) of the starter magnetic switch (6).
4. Pull main fuse (7) out. If it is blown (8), install the spare main fuse (9).

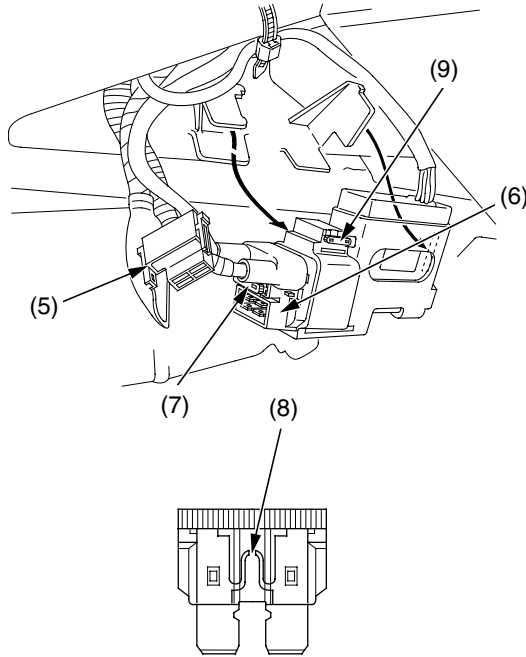

- (5) wire connector
- (6) starter magnetic switch
- (7) main fuse
- (8) blown fuse
- (9) spare main fuse

5. Reconnect the wire connector.

If you do not have a replacement fuse with the proper rating for the circuit, install one with a lower rating.

NOTICE

Replacing a fuse with one that has a higher rating greatly increases the chance of damage to the electrical system.

If you replace a blown fuse with a spare fuse that has a lower rating, replace the fuse with the correct rating as soon as you can. Also remember to replace the spare fuse that was installed.

If the replacement fuse of the same rating burns out in a short time, there is probably a serious electrical problem on your CRF. Leave the blown fuse in that circuit and have your CRF checked by your Honda dealer.

If Your Battery Is Low (or Dead)

Jump-starting is not recommended, especially if you use an automobile battery.

The greater amperage of an automobile battery when the car engine is running can damage your CRF's electrical system.

Bump starting is also not recommended.

If you can't charge the battery or it appears unable to hold a charge, contact your Honda dealer.

This section contains dimensions, capacities, and other technical data.

Vehicle Identification	150
Specifications	151
Torque Specifications	154
High Altitude Carburetor Adjustment	157
Emission Control Systems	158
Oxygenated Fuels	160
Competition Logbook	161
Optional Parts List	163
Spare Parts & Equipment	164
Wiring Diagram.....	165

Vehicle Identification

Serial Numbers

The VIN and engine serial numbers are required when you register your CRF. They may also be required when ordering replacement parts. You may record these numbers in the Quick Reference section at the rear of this manual.

The VIN (vehicle identification number) (1) is stamped on the right side of the steering head.

RIGHT SIDE

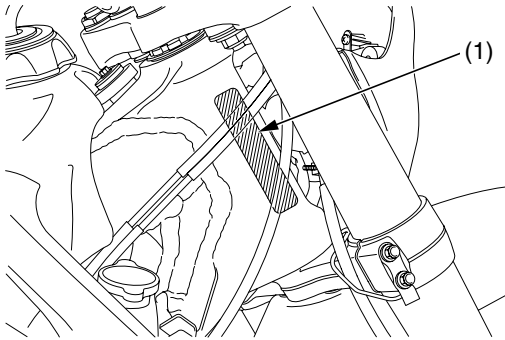

(1) VIN

The engine number (2) is stamped on the left crankcase.

LEFT SIDE

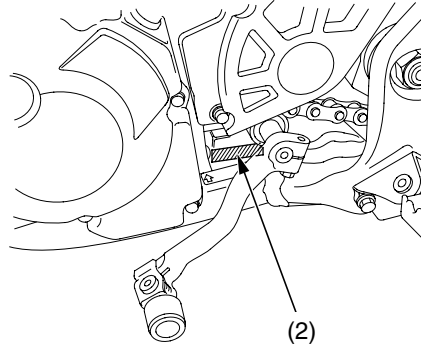

(2) engine number

For USA (except California)

Item	English	Metric
Dimension		
Overall length	85.5 in	2,172 mm
Overall width	32.6 in	827 mm
Overall height	49.6 in	1,261 mm
Wheelbase	58.3 in	1,481 mm
Seat height	37.7 in	958 mm
Footpeg height	17.0 in	432 mm
Ground clearance	13.6 in	346 mm
Frame		
Type	Twin tube	
F. suspension	Telescopic fork, travel 11.0 in (280 mm) stroke 12.4 in (315 mm)	
R. suspension	Pro-link, travel 12.3 in (312 mm)	
Tire size, front	80/100 – 21 51M	
	DUNLOP	D742F
Tire size, rear	100/100 – 18 59M	
	DUNLOP	D756
Tire type	bias-ply, tube	
Tire pressure, front (cold)	15 psi (100kPa, 1.0 kgf/cm ²)	
Tire pressure, rear (cold)	15 psi (100kPa, 1.0 kgf/cm ²)	
F. brake, swept area	Single disc brake 51.8 in ² (334.5 cm ²)	
R. brake, swept area	Single disc brake 60.6 in ² (391.1 cm ²)	
Fuel recommendation	unleaded gasoline, pump octane number of 91 or higher	
Fuel tank capacity	2.19 US gal	8.3 ℓ
Fuel reserve capacity	0.40 US gal	1.5 ℓ
Caster angle	27°54'	
Trail length	4.6 in	118 mm
Fork oil capacity (except fork damper per leg)	11.8 US oz	348 cm ³

Item	English	Metric
Engine		
Type	Liquid cooled, 4-stroke	
Cylinder arrangement	Single 10° inclined from vertical	
Bore and stroke	3.07 x 2.06 in	78.0 x 52.2 mm
Displacement	15.2 cu-in	249 cm ³
Compression ratio	12.9 : 1	
Valve clearance (cold)	Intake: 0.005 ± 0.001 in (0.12 ± 0.03 mm) Exhaust: 0.011 ± 0.001 in (0.28 ± 0.03 mm)	
Engine oil capacity at draining	0.70 US qt	0.66 ℓ
at draining and oil filter change	0.73 US qt	0.69 ℓ
at disassembly	0.90 US qt	0.85 ℓ
Transmission oil capacity at draining	0.71 US qt	0.67 ℓ
at disassembly	0.79 US qt	0.75 ℓ
Cooling system, capacity at draining	1.19 US qt	1.13 ℓ
at disassembly	1.27 US qt	1.20 ℓ
Carburetor		
Type	Piston valve	
Identification number	FCR02B	
Main jet	# 130	
Jet needle	NLAT	
Slow jet	# 42	
Pilot screw opening	2 1/4 turns out	
Float level	0.31 in	8.0 mm
Idle speed	1,700 ± 100 rpm	

Item	English	Metric
Drive train		
Clutch type	Wet, multi-plate type	
Transmission	5-speed, constant mesh	
Primary reduction	3.611	
Gear ratio I	2.384	
Gear ratio II	1.750	
Gear ratio III	1.333	
Gear ratio IV	1.041	
Gear ratio V	0.814	
Final reduction	3.786	
Gear shift pattern	Left foot-operated return system 1-N-2-3-4-5	
Electrical		
Battery	12V-4 Ah	
Ignition	ICM	
Starting system	Electric, Kickstarter	
Spark plug : Standard	NGK	IMR8C-9H
	DENSO	VUH24D
For extended high speed riding	NGK	IMR9C-9H
	DENSO	VUH27D
Spark plug gap	0.03 – 0.04 in (0.8 – 0.9 mm)	
Light		
Head light	12V-35 W	
Fuse		
Main fuse	15 A	

Specifications

For California

Item	English	Metric
Dimension		
Overall length	85.5 in	2,172 mm
Overall width	32.6 in	827 mm
Overall height	49.6 in	1,261 mm
Wheelbase	58.3 in	1,481 mm
Seat height	37.7 in	958 mm
Footpeg height	17.0 in	432 mm
Ground clearance	13.6 in	346 mm
Frame		
Type	Twin tube	
F. suspension	Telescopic fork, travel 11.0 in (280 mm) stroke 12.4 in (315 mm)	
R. suspension	Pro-link, travel 12.3 in (312 mm)	
Tire size, front	80/100 – 21 51M	
	DUNLOP	D742F
Tire size, rear	100/100 – 18 59M	
	DUNLOP	D756
Tire type	bias-ply, tube	
Tire pressure, front (cold)	15 psi (100kPa, 1.0 kgf/cm ²)	
Tire pressure, rear (cold)	15 psi (100kPa, 1.0 kgf/cm ²)	
F. brake, swept area	Single disc brake 51.8 in ² (334.5 cm ²)	
R. brake, swept area	Single disc brake 60.6 in ² (391.1 cm ²)	
Fuel recommendation	unleaded gasoline, pump octane number of 91 or higher	
Fuel capacity	2.19 US gal	8.3 ℓ
Fuel reserve capacity	0.40 US gal	1.5 ℓ
Caster angle	27°54'	
Trail length	4.6 in	118 mm
Fork oil capacity (except fork damper per leg)	11.8 US oz	348 cm ³

Item	English	Metric
Engine		
Type	Liquid cooled, 4-stroke	
Cylinder arrangement	Single 10° inclined from vertical	
Bore and stroke	3.07 x 2.06 in	78.0 x 52.2 mm
Displacement	15.2 cu-in	249 cm ³
Compression ratio	12.9 : 1	
Valve clearance (cold)	Intake: 0.005 ± 0.001 in (0.12 ± 0.03 mm) Exhaust: 0.011 ± 0.001 in (0.28 ± 0.03 mm)	
Engine oil capacity at draining	0.70 US qt	0.66 ℓ
at draining and oil filter change	0.73 US qt	0.69 ℓ
at disassembly	0.90 US qt	0.85 ℓ
Transmission oil capacity at draining	0.71 US qt	0.67 ℓ
at disassembly	0.79 US qt	0.75 ℓ
Cooling system, capacity at draining	1.19 US qt	1.13 ℓ
at disassembly	1.27 US qt	1.20 ℓ
Carburetor		
Type	Piston valve	
Identification number	FCR03B	
Main jet	# 132	
Jet needle	NLBU	
Needle clip position (standard)	2nd groove	
Slow jet	# 42	
Pilot screw opening	2 1/4 turns out	
Float level	0.31 in	8.0 mm
Idle speed	1,700 ± 100 rpm	

Item	English	Metric
Drive train		
Clutch type	Wet, multi-plate type	
Transmission	5-speed, constant mesh	
Primary reduction	3.611	
Gear ratio I	2.384	
Gear ratio II	1.750	
Gear ratio III	1.333	
Gear ratio IV	1.041	
Gear ratio V	0.814	
Final reduction	3.786	
Gear shift pattern	Left foot-operated return system 1-N-2-3-4-5	
Electrical		
Battery	12V-4 Ah	
Ignition	ICM	
Starting system	Electric, Kickstarter	
Spark plug : Standard	NGK	IMR8C-9H
	DENSO	VUH24D
For extended high speed riding	NGK	IMR9C-9H
	DENSO	VUH27D
Spark plug gap	0.03 – 0.04 in (0.8 – 0.9 mm)	
Light		
Head light	12V-35 W	
Fuse		
Main fuse	15 A	

For CANADA

Item	English	Metric
Dimension		
Overall length	85.5 in	2,172 mm
Overall width	32.6 in	827 mm
Overall height	49.6 in	1,261 mm
Wheelbase	58.4 in	1,483 mm
Seat height	37.7 in	958 mm
Footpeg height	17.0 in	432 mm
Ground clearance	13.6 in	346 mm
Frame		
Type	Twin tube	
F. suspension	Telescopic fork, travel 11.0 in (280 mm) stroke 12.4 in (315 mm)	
R. suspension	Pro-link, travel 12.3 in (312 mm)	
Tire size, front	80/100 – 21 51M	
	DUNLOP	D742F
Tire size, rear	100/100 – 18 59M	
	DUNLOP	D756
Tire type	bias-ply, tube	
Tire pressure, front (cold)	15 psi (100kPa, 1.0 kgf/cm ²)	
Tire pressure, rear (cold)	15 psi (100kPa, 1.0 kgf/cm ²)	
F. brake, swept area	Single disc brake 51.8 in ² (334.5 cm ²)	
R. brake, swept area	Single disc brake 60.6 in ² (391.1 cm ²)	
Fuel recommendation	unleaded gasoline, pump octane number of 91 or higher	
Fuel tank capacity	2.19 US gal	8.3 ℓ
Fuel reserve capacity	0.40 US gal	1.5 ℓ
Caster angle	27°54'	
Trail length	4.6 in	118 mm
Fork oil capacity (except fork damper per leg)	11.8 US oz	348 cm ³

Item	English	Metric
Engine		
Type	Liquid cooled, 4-stroke	
Cylinder arrangement	Single 10° inclined from vertical	
Bore and stroke	3.07 x 2.06 in	78.0 x 52.2 mm
Displacement	15.2 cu-in	249 cm ³
Compression ratio	12.9 : 1	
Valve clearance (cold)	Intake: 0.005 ± 0.001 in (0.12 ± 0.03 mm) Exhaust: 0.011 ± 0.001 in (0.28 ± 0.03 mm)	
Engine oil capacity at draining	0.70 US qt	0.66 ℓ
at draining and oil filter change	0.73 US qt	0.69 ℓ
at disassembly	0.90 US qt	0.85 ℓ
Transmission oil capacity at draining	0.71 US qt	0.67 ℓ
at disassembly	0.79 US qt	0.75 ℓ
Cooling system, capacity at draining	1.19 US qt	1.13 ℓ
at disassembly	1.27 US qt	1.20 ℓ
Carburetor		
Type	Piston valve	
Identification number	FCR02B	
Main jet	# 130	
Jet needle	NLAT	
Slow jet	# 42	
Pilot screw opening	2 1/4 turns out	
Float level	0.31 in	8.0 mm
Idle speed	1,700 ± 100 rpm	

Item	English	Metric
Drive train		
Clutch type	Wet, multi-plate type	
Transmission	5-speed, constant mesh	
Primary reduction	3.611	
Gear ratio I	2.384	
Gear ratio II	1.750	
Gear ratio III	1.333	
Gear ratio IV	1.041	
Gear ratio V	0.814	
Final reduction	3.786	
Gear shift pattern	Left foot-operated return system 1-N-2-3-4-5	
Electrical		
Battery	12V-4 Ah	
Ignition	ICM	
Starting system	Electric, Kickstarter	
Spark plug : Standard	NGK	IMR8C-9H
	DENSO	VUH24D
For extended high speed riding	NGK	IMR9C-9H
	DENSO	VUH27D
Spark plug gap	0.03 – 0.04 in (0.8 – 0.9 mm)	
Light		
Head light	12V-35 W	
Fuse		
Main fuse	15 A	

Torque Specifications

Nuts, Bolts, Fasteners

Check and tighten nuts, bolts, and fasteners before every outing.

Engine

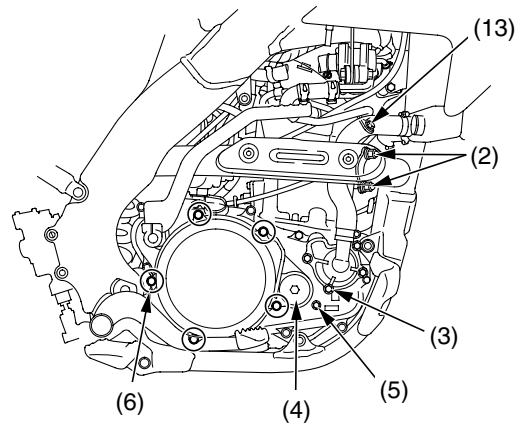
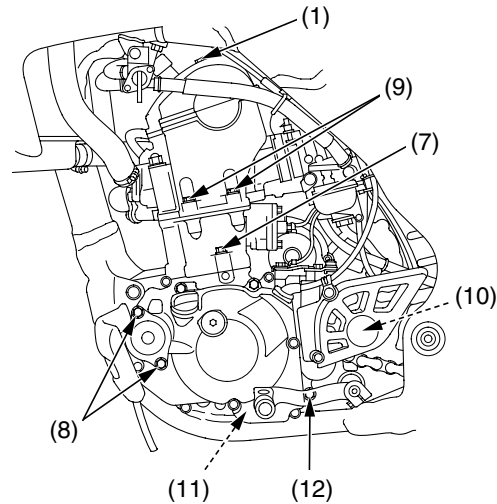

ENGINE

	Item	Torque			Remarks
		lbf•ft	N•m	kgf•m	
1	Cylinder head cover bolts	7	10	1.0	
2	Exhaust pipe joint nuts	15	21	2.1	
3	Coolant drain bolt	7	10	1.0	
4	Crankshaft hole cap	11	15	1.5	NOTE 1
5	Transmission oil check bolt	9	12	1.2	
6	Clutch cover bolts	7	10	1.0	
7	Cylinder bolt	7	10	1.0	
8	Oil filter cover bolts	9	12	1.2	
9	Cylinder head bolts	7	10	1.0	
10	Drive sprocket bolt	23	31	3.2	
11	Engine oil drain bolt	12	16	1.6	NOTE 2
12	Transmission oil drain bolt	12	16	1.6	NOTE 2
13	Air supply pipe bolt	7	10	1.0	

NOTE: 1. Apply grease to the threads.

2. Apply engine oil to the threads.

Frame

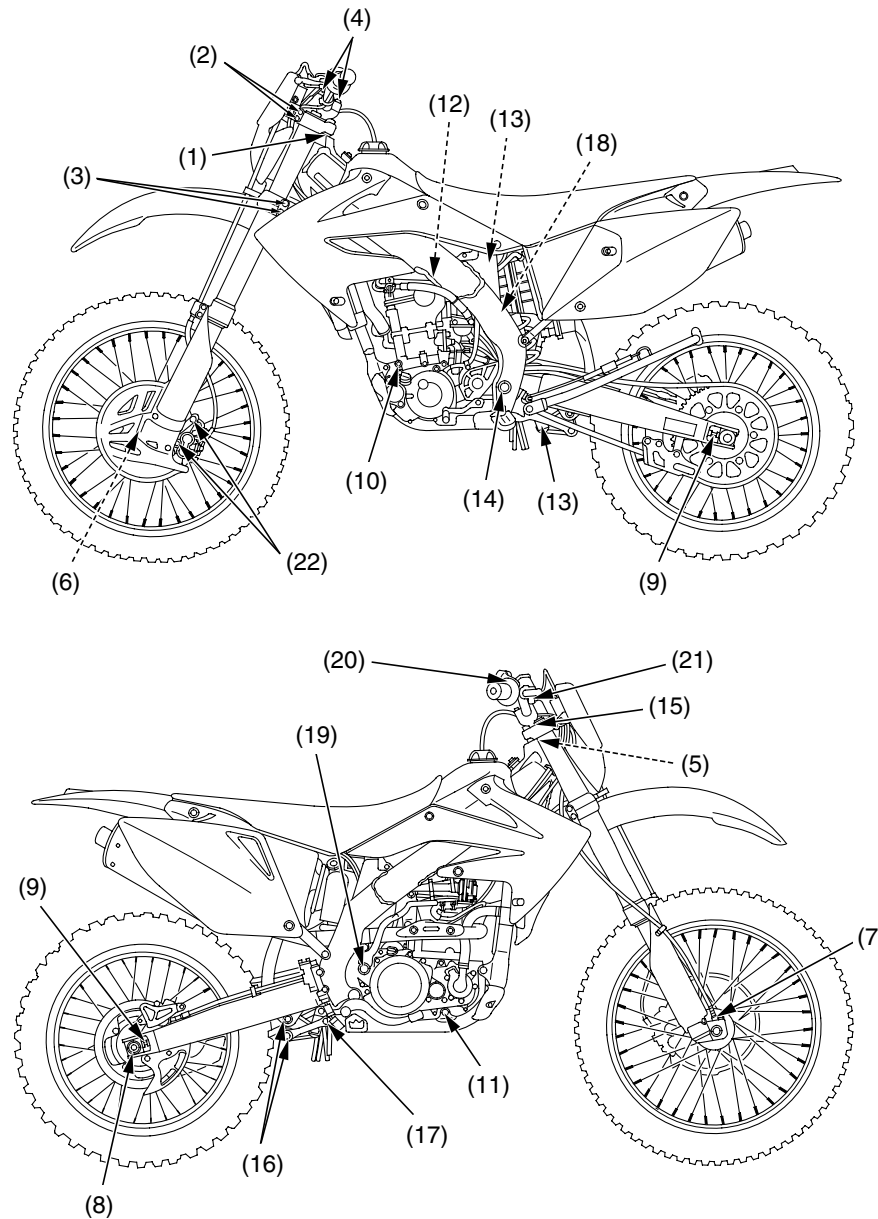

FRAME

	Item	Torque			Remarks
		lbf•ft	N•m	kgf•m	
1	Steering stem nut	80	108	11.0	
2	Fork upper pinch bolts	16	22	2.2	
3	Fork lower pinch bolts	15	20	2.0	
4	Handlebar upper holder bolts	16	22	2.2	
5	Handlebar holder nuts	32	44	4.5	
6	Front axle nut	65	88	9.0	
7	Front axle pinch bolts	15	20	2.0	
8	Rear axle nut	94	127	13.0	NOTE 2
9	Chain adjuster lock nuts	20	27	2.8	NOTE 3
10	Front engine hanger bracket nut	40	54	5.5	
11	Mid engine hanger bracket nut	47	64	6.5	
12	Upper engine hanger plate nuts (engine side) (frame side)	40	54	5.5	
		25	34	3.5	
13	Shock absorber (upper) nuts (lower)	32	44	4.5	NOTE 2
		32	44	4.5	NOTE 2
14	Swingarm pivot nut	65	88	9.0	NOTE 2
15	Fork (fork damper) (fork cap)	25	34	3.5	
		22	30	3.1	
16	Rear shock arm nuts (swingarm side) (shock link side)	39	53	5.4	NOTE 1, 2
		39	53	5.4	NOTE 1, 2
17	Rear shock link nuts	39	53	5.4	NOTE 1, 2
18	Shock spring lock nut	32	44	4.5	
19	Kickstarter arm bolt	28	38	3.9	
20	Front brake master cylinder holder bolts	7.3	9.9	1.0	
21	Brake hose bolts	25	34	3.5	
22	Caliper mounting bolts	22	30	3.1	NOTE 4

NOTES: 1. Apply oil to the threads and flange surface.
 2. U-nut.
 3. UBS nut.
 4. Alock bolt : Replace with a new one.

Torque Specifications

Frame

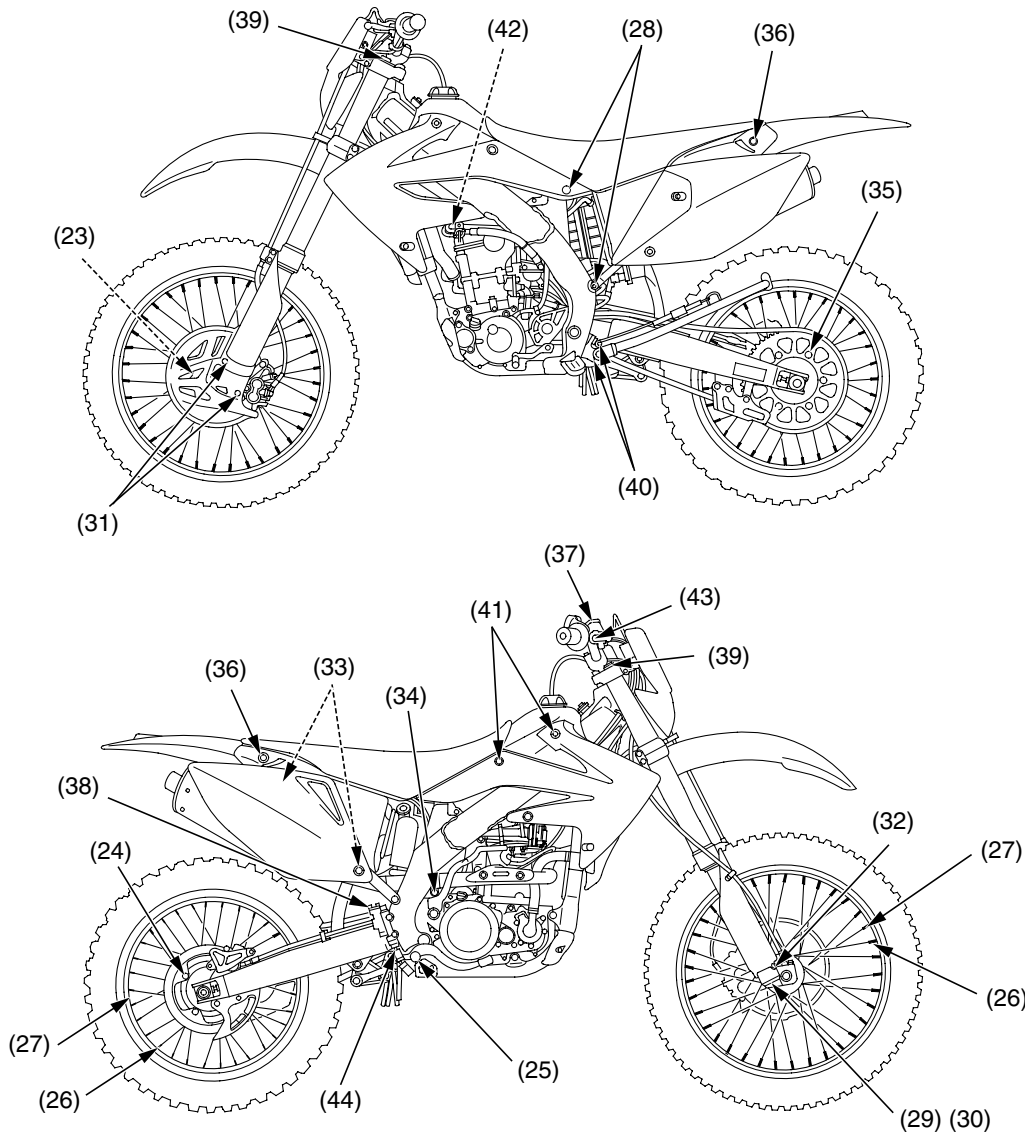

FRAME

	Item	Torque			Remarks
		lbf•ft	N•m	kgf•m	
23	Front brake disc nuts	12	16	1.6	NOTE 2
24	Rear brake disc nuts	12	16	1.6	NOTE 2
25	Rear brake pedal pivot bolt	27	36	3.7	
26	Spokes	2.7	3.68	0.4	
27	Rim locks	9	12	1.2	
28	Subframe (upper) mounting bolts	22	30	3.1	
	(lower)	36	49	5.0	
29	Fork center bolt	51	69	7.0	
30	Fork center bolt lock nut	16	22	2.2	
31	Disc cover bolts	10	13	1.3	
32	Fork protector bolts	5.2	7	0.7	NOTE 4
33	Muffler mounting bolts				
	(front)	19	26	2.7	
	(rear)	19	26	2.7	
34	Muffler clamp bolt	15	21	2.1	
35	Driven sprocket nuts	24	32	3.3	NOTE 2
36	Seat mounting bolts	19	26	2.7	
37	Front brake reservoir cap screws	0.7	1.0	0.1	
38	Rear brake reservoir cap bolts	0.7	1.0	0.1	
39	Fork air pressure release screw	0.9	1.2	0.1	
40	Side stand mounting bolts				
	(upper)	40	54	5.5	
	(lower)	29	39	4.0	
41	Shroud B bolts	3.7	5	0.5	
42	Fuel joint bolts	7	10	1.0	
43	Brake lever adjuster lock nut	4.4	5.9	0.6	
44	Brake pedal adjuster lock nut	4.4	5.9	0.6	

- NOTES:
1. Apply oil to the threads and flange surfaces.
 2. U-nut.
 3. UBS nut.
 4. Alock bolt: Replace with a new one.

High Altitude Carburetor Adjustment (California only)

At high altitude, the standard carburetor air-fuel mixture will be too rich. Performance will decrease, and fuel consumption will increase. A very rich mixture will also foul the spark plug and cause hard starting. Operation at an altitude that differs from that at which this engine was certified, for extended periods of time, may increase emissions.

High altitude performance can be improved by specific modifications to the carburetor. If you always operate your engine at altitudes above 6,500 feet (2,000 meters), have your servicing dealer perform this carburetor modification. This engine, when operated at high altitude with the carburetor modifications for high altitude use, will meet each emission standard throughout its useful life.

Even with carburetor modification, engine horsepower will decrease about 3.5% for each 1,000-foot (300-meter) increase in altitude. The effect of altitude on horsepower will be greater than this if no carburetor modification is made.

NOTICE

When the carburetor has been modified for high altitude operation, the air-fuel mixture will be too lean for low altitude use. Operation at altitudes below 5,000 feet (1,500 meters) with a modified carburetor may cause the engine to overheat and result in serious engine damage. For use at low altitudes, have your servicing dealer return the carburetor to original factory specifications.

Emission Control Systems

Exhaust Emission Requirements (USA only)

The U.S. Environmental Protection Agency (EPA) and the California Air Resources Board (CARB) require that your motorcycle comply with applicable exhaust emission standards during its useful life, when operated and maintained according to the instructions provided.

The vehicle emission control information label (1) is attached to the rear fender.

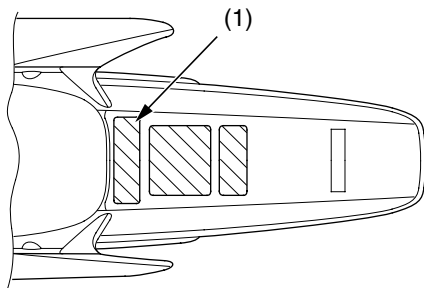

(1) vehicle emission control information label

Noise Emission Requirements

The EPA also requires that motorcycles built after January 1, 1983 comply with applicable noise emission standards for one year or 1,865 miles (3,000 km) after the time of sale to the ultimate purchaser, the time operated and maintained according to the instructions provided. (USA only)

Noise Emission Control System

TEMPERING WITH THE NOISE CONTROL SYSTEM IS PROHIBITED: U.S. federal law prohibits, or Canadian provincial laws may prohibit the following acts or the causing thereof. (1) The removal or rendering inoperative by any person, other than for purposes of maintenance, repair or replacement, of any device or element of design incorporated into any new vehicle for the purpose of noise control prior to its sale or delivery to the ultimate purchaser or while it is in use; or (2) the use of the vehicle after such device or element of design has been removed or rendered inoperative by any person.

AMONG THOSE ACTS PRESUMED TO CONSTITUTE TAMPERING ARE THE ACTS LISTED BELOW:

1. Removal of, or puncturing the muffler, baffles, reader pipes, or any other component which conducts exhaust gases.
2. Removal of, or puncturing of any part of the intake system.
3. Lack of proper maintenance.
4. Replacing any moving parts of the vehicle, or parts of the exhaust or intake system, with parts other those specified by the manufacturer.

Problems that May Affect Motorcycle Emissions

If you are aware of any of the following symptoms, have the vehicle inspected and repaired by your Honda dealer.

1. Hard starting or stalling after starting.
2. Rough idle.
3. Misfiring or backfiring during acceleration.
4. After-burning (backfiring).
5. Poor performance (drive ability) and poor fuel economy.

Federal regulations prohibit removing or disabling a device or element of design that may affect your engines's emission performance unless your CRF will be used exclusively in competition. If you modify your engine for use in sanctioned competition events, you must deface or destroy the emission control information label.

Source of Emission

The combustion process produces carbon monoxide (CO), oxides of nitrogen (NOx), and hydrocarbons (HC).

Control of hydrocarbons and oxides of nitrogen is very important because, under certain conditions, they react to form photochemical smog when subjected to sunlight. Carbon monoxide does not react in the same way, but it is toxic.

Honda Motor Co., Ltd. utilizes various systems to reduce carbon monoxide, oxides of nitrogen and hydrocarbons.

Exhaust Emission Control System

The exhaust emission control system is composed of appropriate carburetor settings.

No adjustments should be made except for an idle speed adjustment with the throttle stop screw.

The exhaust emission control system is separate from the crankcase emission control system.

Secondary Air Injection System

The exhaust emission control system consists of a secondary air injection system.

The secondary air injection system introduces filtered air into the exhaust gases in the exhaust port. The secondary air injection system helps improve emission performance.

No adjustments to this system should be made although periodic inspection of the components is recommended.

Crankcase Emission Control System

The engine is equipped with a closed crankcase system to prevent discharging crankcase emissions into the atmosphere.

Blow-by gas is returned to the combustion muffler through the air cleaner and the carburetor.

Oxygenated Fuels

Some conventional gasolines are being blended with alcohol or an ether compound. These gasolines are collectively referred to as oxygenated fuels. To meet clean air standards, some areas of the United States and Canada use oxygenated fuels to help reduce emissions.

If you use an oxygenated fuel, be sure it is unleaded and meets the minimum octane rating requirement.

Before using an oxygenated fuel, try to confirm the fuel's contents. Some states/provinces require this information to be posted on the pump.

The following are the EPA-approved percentages of oxygenates:

ETHANOL (ethyl or grain alcohol) 10% by Volume

You may use gasoline containing up to 10% ethanol by volume. Gasoline containing ethanol may be marketed under the name "Gasohol".

MTBE (Methyl Tertiary Butyl Ether) 15% by Volume

You may use gasoline containing up to 15% MTBE by volume.

METHANOL (methyl or wood alcohol) 5% by Volume

You may use gasoline containing methanol containing up to 15% methanol by volume as long as it contains cosolvents and corrosion inhibitors to protect the fuel system. Gasoline containing more than 5% methanol by volume may cause starting and/or performance problems. It may also damage metal, rubber, and plastic parts of your fuel system.

If you notice any undesirable operating symptoms, try another service station or switch to another brand of gasoline.

Fuel system damage or performance problems resulting from the use of an oxygenated fuel containing more than the percentages of oxygenates mentioned above are not covered under warranty.

Oxygenated the fuels can damage paint and plastic. Be careful not to spill fuel when filling the fuel tank. Wipe up any spills immediately.

NOTICE

Oxygenated fuels can damage paint and plastic.

Any serious competition effort relies heavily on the knowledge gained and compiled from previous racing events. The best way to organize the many bits of information is to record them in a logbook.

Your logbook can include such information as suspension adjustments, gearing, and tire selection. This detailed information, along with your comments, can prove valuable when you compete at the same track or on similar terrain.

Your logbook can also tell you when maintenance was performed and when it will be necessary again. Your logbook also lets you record any repairs and lets you keep track of the running time on the engine and suspension components.

If you choose to sell your CRF, the accurate maintenance records in your logbook might be the deciding deal-maker for a potential buyer.

Consider using different color pens or pencils to record important information on specific subjects. For example, record results in black, suspension/chassis settings in blue, and gearing selections in green. Color codes will help you identify the information you want with a glance.

Tuning & Adjustment Records

Keep track of the settings and adjustments that worked best at a particular location. These items include:

- basic track conditions, altitude, and temperature
- suspension settings
- chassis adjustments tested and selected
- gearing
- tire selection
- air pressure

Competition Records

- your placings
- thoughts to improve performance next time: both yours and your CRF's
- strategy notes

Maintenance Records

- regular interval maintenance
- repairs
- running time on engine
- running time on suspension components

Timekeeping

This Manual lists maintenance intervals for every-so-many hours of running.

The most effective way to schedule maintenance is by the hours you have run your CRF.

An official “guesstimate” is close enough for our timekeeping purposes. You may choose to record your time the same way aircraft operators do (but without the benefit of an electrical hourmeter).

All running time is broken down into hours and tenths of an hour (each 6 minutes represents one tenth of an hour).

Racing Records

Information worth recording for this section of your logbook may include:

- Your placing in each moto and overall finishing position.
- Thoughts on what you could do to improve your performance next time.
- Notes on any patterns noted in choice of starting gate positions or in riding portions of the course as the day progressed that may prove helpful in future events.
- Any places on the course where you chose the wrong line and were passed too easily.
- Notes on strategy used by your competition or by riders in another event that are worth remembering.

Maintenance Records

Regular maintenance items you'll want to record in your logbook should include:

- Dates and results of cylinder, piston and ring examinations
- Patterns for frequency of need for decarbonization with a particular oil
- When you last performed shock linkage and swingarm pivot bearing maintenance
- Engine, transmission, and suspension oil changes
- chain, sprocket, chain guide and slider replacements
- coolant changes and related component replacements
- Spark plug, brake pad and control cable replacements

In addition, you should record any irregularities noted in component wear so you'll remember to keep a close eye on these areas in the future.

Competition Logbook

Date	Running Time	Location/Event	Comments (Suspension Settings, Gearing, Chassis Adjustments, Maintenance Performed, etc.)



(Make several photocopies of this page for future use)



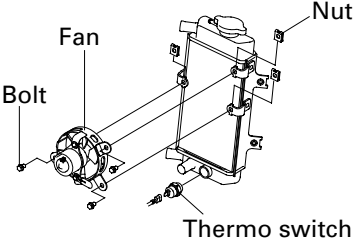

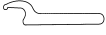

Optional Parts List

These parts and tools may be ordered from your authorized Honda dealer.

ENGINE	Remarks
Cooling system assembly	 <p>An optional cooling fan is available for competition use. The fan will help avoid the engine damage if the engine is kept idling too long when hot, or when riding in mud or sand or any condition that causes high engine load at low vehicle speed.</p>

FRAME	Remarks
Driven sprocket Standard	< >: Drive chain links 53 Teeth, Aluminum. <116>
Optional	54 Teeth, Aluminum <116>
	52 Teeth, Aluminum <116>
Drive chain size/link	DID 520MXV/120ZB
Handlebar lower holder	
	Standard 3 mm offset Optional no offset

TOOLS	Remarks
Pin spanner A 	To adjust spring pre-load. (two spanners required)
Workstand 	For maintenance
Air gauge	For checking tire air pressure.

FRAME	Remarks
Shock spring Standard	268.8 lbf/in (4.80 kgf/mm)
	 No mark (factory products) or  Orange paint (aftermarket parts)
Optional Softer	254.8 lbf/in (4.55 kgf/mm)
	 Red and Black paint
Stiffer	280 lbf/in (5.00 kgf/mm)
	 White paint 291.2 lbf/in (5.20 kgf/mm)  Blue paint
Fork spring Standard	23.52 lbf/in (0.42 kgf/mm)
	 No mark (factory products) or  2 scribe marks (aftermarket parts)
Optional Softer	22.4 lbf/in (0.40 kgf/mm) 3 scribe marks
Stiffer	24.64 lbf/in (0.44 kgf/mm) 1 scribe mark

The standard fork spring and shock spring mounted on the motorcycle when it leaves the factory are not marked. Before replacing the springs, be sure to mark them so they can be distinguished from other optional springs.

Spare Parts & Equipment

There are numerous spare parts you can take to an event to help ensure you get in a full day of riding. In addition to the usual nuts and bolts, consider the following:

Spare Parts

spark plugs
air cleaner (clean & oiled, sealed in a plastic bag)
chain & masterlinks
chain guide slider
chain guide
chain rollers
inner tubes (front & rear)
fenders
footpegs
front visor & side covers
handlebar
grips
levers (brake, clutch & hot start)
clutch lever handlebar mount
clutch cable
hot start cable
throttle assembly
throttle cable
shift lever
rear brake pedal
spokes (front & rear, each side)
sprockets (smaller than standard, for gearing changes & collision damage replacement)
assorted nuts, bolts, washers, screws, cotter pins
headlight bulbs
battery
fuses

Additional Spares

front brake assembly
rear brake assembly
wheels & tires (front & rear, mounted)
clutch discs and plates
engine & transmission oil

seat
ignition components
radiator hoses
radiator shrouds (L & R)
brake hoses (front & rear)

General Tools

sockets (3/8 in drive)
screwdrivers: blade & Phillips No. 1, 2, 3
wrench, large adjustable
wrenches: open end & box
wrenches: hex (Allen)
wrench, spoke
torque wrench (metric scale, click-stop style)
pliers: standard, needle-nose, channel-lock set
hammer, plastic head
syringe with adjustable stop
tire pressure gauge
tire irons
tire pump or air tank
feeler gauge set
vernier caliper (metric)
pressure/vacuum testing equipment (USA only)

Honda Special Tools

Any special tools for your motorcycle purchased from your Honda dealer.

- Clutch Center Holder 07724-0050001 or 07724-0050002
- Lock Nut Wrench 07WMA-KZ30100
- Tensioner Stopper 070MG-0010100
- Spoke Wrench 07JMA-MR60100
- Piston base 07958-2500001

Chemical Products

Pro Honda GN4 4-stroke Oil (Engine and Transmission Oil)
Pro Honda HP Fork Oil 5W
Pro Honda DOT 4 Brake Fluid
Pro Honda Chain Lube
Pro Honda Foam Filter Oil
Pro Hondabrite cleaner
Pro Honda Dielectric Grease
Pro Honda Handgrip Cement
Pro Honda Hondalock
Molybdenum disulfide grease (containing more than 3% molybdenum disulfide additive)
Pro Honda White Lithium Grease
Multi-purposes Grease
Rust-inhibiting oil cable lubricant
Pro Honda HP Coolant
Urea based multi-purpose grease designed for high temperature, high pressure performance (example: EXCELITE EP2 manufactured by KYODO YUSHI, Japan or Shell Stamina EP2 or equivalent).

Other Products

pliers-safety wire
safety wire
mechanic's wire
duct tape
plastic tie-wraps
hose clamps
drop light
electrical tape

Wiring Diagram

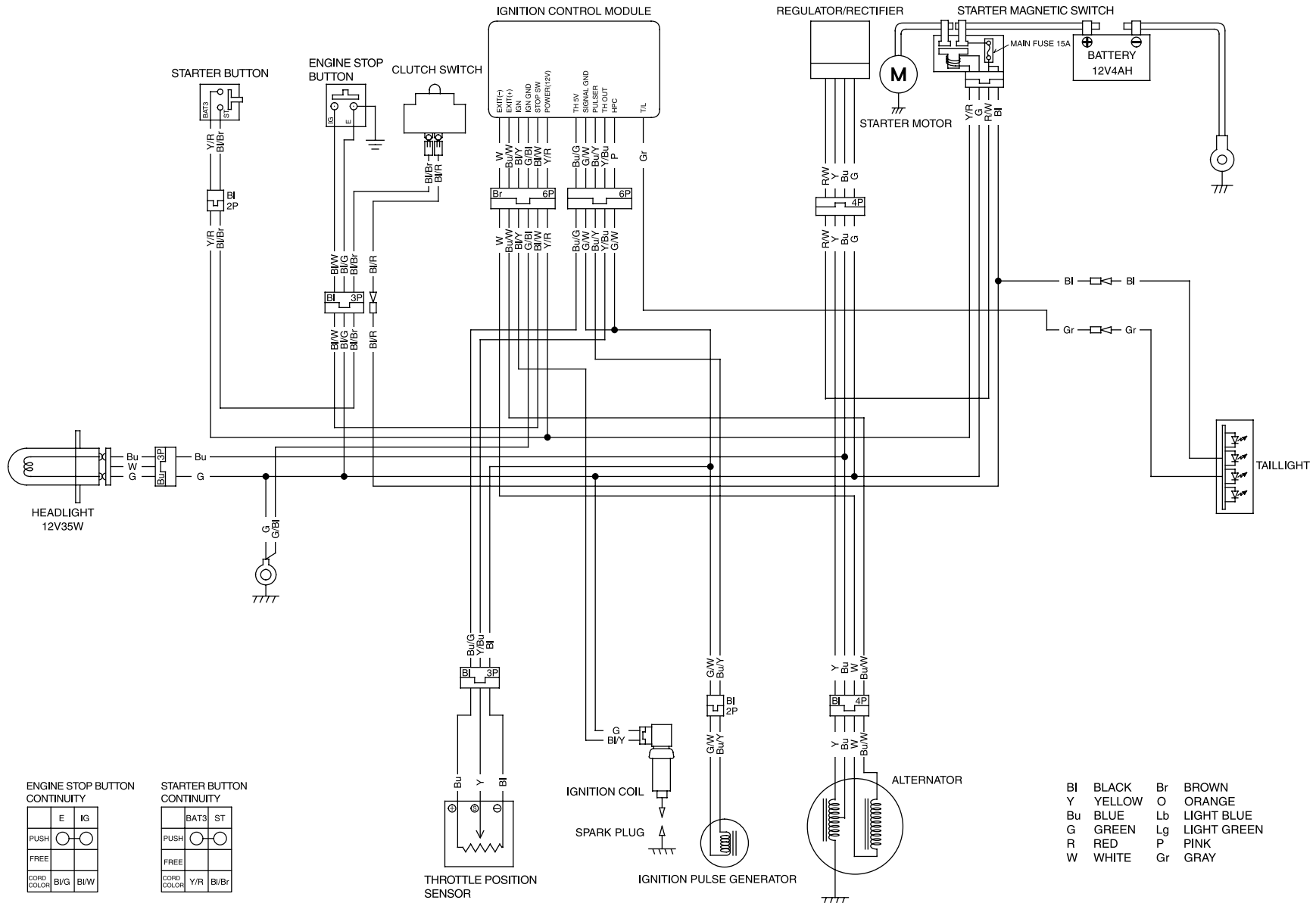

This section contains information about contacting Honda and how to get an official Honda service manual.

Authorized Manuals168
Warranty Coverage.....169
Warranty Service170
Contacting Honda.....171
Your Honda Dealer.....172
The Honda Rider’s Club (USA only)173

Authorized Manuals

The Service Manual used by your authorized Honda dealer is available from Helm, Inc. (USA only, Canada: See your Honda dealer to order authorized manuals)

Also available but not necessary to service your model is the Honda Common Service Manual which explains theory of operation and basic service information for various systems common to all Honda motorcycles, motor scooters and ATVs.

These Honda manuals are written for the professional technician, but most mechanically-capable owners should find them helpful if they have the proper tools and skills. Special Honda tools are necessary for some procedures.

Publication Item No.	Description	Price Each*
61KSC03	2007 CRF250X Service Manual	\$48.00
61CM002	Common Manual	\$48.00
31KSC630	2007 CRF250X Owner's Manual	\$16.00

*Prices are subject to change without notice and without incurring obligation.

Order On-Line: www.helminc.com

Order Toll Free: 1-888-CYCLE93 (1-888-292-5393)

(NOTE: For Credit Card Orders Only)

Monday - Friday 8:00 AM - 6:00 PM EST

OR

By completing this form you can order the materials desired. You can pay by check or money order, or charge to your credit card. Mail to Helm, Incorporated, at the address shown on this order form. (USA only)
Canada: See your Honda dealer to order authorized manuals.

Publication Item No.	Item Description	Qty.	Price Each*	Total Price
*Prices are subject to change without notice and without incurring obligation.		Sub Total		
		Purchaser's Sales Tax Mich. Add 6 % Calif. Add 8.25 %		
Orders are mailed within 10 days. Please allow adequate time for delivery.		Handling Charge		\$5.00
		Grand Total		

**S
H
I
P
T
O**

NOTE: Dealers and Companies, please provide dealer or company name, and also the name of the person to whose attention the shipment should be sent. For purchases outside U.S.A., please write to the address shown below for a quotation.

Customer Name _____

Attention _____

Street Address-No P.O. Box Number _____ Apt. # _____

City _____ State _____ Zip Code _____

Daytime Telephone Number () _____

**P
A
Y
M
E
N
T**

Check or money order enclosed payable to Helm, Inc. U.S. funds only. Do not send cash.

Master Card

VISA

Discover

Check here if your billing address is different from the shipping address shown above.

Account Number

--	--	--	--	--	--	--	--	--	--	--	--

Expiration Date: Mo. Yr

--	--	--	--

Customer Signature _____ Date _____

These Publications cannot be returned for credit without receiving advance authorization within 14 days of delivery. On returns, a restocking fee may be applied against the original order.

HELM P.O. BOX 07280, DETROIT MICHIGAN 48207

Your new Honda is covered by these warranties:

- Motorcycle Limited Warranty
- Exhaust Emission Warranty (USA only)
- Noise Control Warranty (USA only)

There are responsibilities, restrictions, and exclusions which apply to these warranties. Please read the Honda Motorcycle Warranties Booklet given to you by your Honda dealer at the time of purchase. Be sure to keep your Honda owner's card (USA only) with your Warranties Booklet.

It is important to realize that your warranty for your Honda applies to defects in material or factory workmanship. Your warranty coverage does not apply to normal wear or deterioration associated with using the motorcycle.

Your warranty coverage will not be voided if you choose to perform your own maintenance. However, you should have the proper tools and service information and be mechanically qualified. Failures that occur due directly to improper maintenance or lack of maintenance are not covered.

Almost all of your warranty coverage can be extended through the Honda Protection Plan (USA only). For more information, see your Honda dealer.

Warranty Service

Please remember that recommended maintenance interval servicing is not included in your warranty coverage. Additionally, your warranty does not apply to the normal wear of items (such as brakes, tires etc.).

If you believe you have a problem with your Honda, call the service department of your Honda dealer. Make an appointment for an inspection and diagnosis. Remember, as the owner of the motorcycle, you will be asked to authorize that inspection. Your dealer will give you the results of the inspection. If the problem is covered under warranty, your dealer will perform the warranty repairs for you.

If you have questions about warranty coverage or the nature of the repair, it is best to talk to the service manager of your Honda dealer.

Sometimes, in spite of the best intentions of all concerned, a misunderstanding may occur. If you aren't satisfied with your dealer's handling of the situation, we suggest you discuss your problem with the appropriate member of the dealership's management team. If the problem has already been reviewed with the service Manager, Parts Manager, Sales Manager, etc., contact the Owner of the dealership or his designated representative.

Your owner's manual was written to cover most of the questions you might ask about your Honda. Any questions not answered in the owner's manual can be answered by your Honda dealer. If he doesn't have the answer right away, he will get it for you.

If you have a difference of opinion with your dealer, please remember that each dealership is independently owned and operated. That's why it's important to work to resolve any differences at the dealership level.

If you wish to comment on your experiences with your Honda or with your dealer, please send your comments to the following address (USA only):

Motorcycle Division, American Honda Motor Co., Inc., P.O. Box 2200, Torrance CA 90509-2200, mailstop: 100-4C-7B, telephone: (866) 784-1870.

Canada: Refer to the warranty booklet that was supplied with your vehicle.

Please include the following information in your letter:

- name, address, and telephone number
- product model, year, and VIN
- date of purchase
- dealer name and address

We will likely ask your Honda dealer to respond, or possibly acknowledge your comments directly.

Your Honda Dealer

Once you purchase your new Honda, get familiar with the organization of your Honda dealer so you can utilize the full range of services available.

The service department is there to perform regular maintenance and unexpected repairs. It has the latest available service information from Honda.

The parts department offers Genuine Honda parts, Pro Honda products, Hondaline accessories (USA only), and Honda accessories and products (Canada only). The same quality that went into your Honda can be found in Genuine Honda replacement parts. You'll also find comparable quality in the accessories and products available from the parts department.

Your dealer can inform you about competition events in your area. You'll also find that your dealer is a source of information (USA only) the Honda Rider's Club of America.

We're sure you'll be as pleased with the service your Honda dealer continues to provide after the sale as you are with the quality and dependability of your Honda.

One of the best ways to get the most enjoyment from owning and riding your Honda is through the Honda Rider's Club of America. Your purchase of a new motorcycle, scooter, ATV or PWC from a participating U.S. Honda dealer entitles you to a complimentary one-year membership in the Club. There are hundreds of HRC Chapter-sponsoring dealers across the USA with events and activities almost every weekend.

Membership benefits include:

- 24-hour, toll-free roadside assistance for your new Honda (includes roadside assistance for your transport vehicle [up to one ton] as long as your Honda is aboard or in tow). *For street-legal motorcycles and scooters only.*
- An exclusive HRC website complete with access to the official Honda Common Service Manual, contests, insider information and more.
- Reimbursement (up to \$75) for successful completion of a Motorcycle Safety Foundation training course. Separate, complimentary training from the Specialty Vehicle Institute of America for purchasers of new ATVs.
- One full year of *Honda Red Rider* magazine (six issues).
- Discounts from HRC partners for experienced rider courses.
- Discounted vehicle insurance from the HRC's insurance partner.
- Racing contingency programs and assistance at selected dual-sport, off-road and motocross events for off-road motorcycles and selected ATVs.

If you purchased an off-road motorcycle, ATV or PWC, your benefits do not include roadside assistance or trip interruption protection.

Contact your Honda dealer for more information or call: 1-800-847-4722 or log on to www.hrca.honda.com.

Table of Contents

The following presents the contents of each section of your owner's manual.

MOTORCYCLE SAFETY.....1
Important Safety Information.....2
Important Safety Precautions.....2
Loading.....3
Accessories & Modifications4
Safety Labels.....5
OPERATING CONTROLS7
Operation Component Locations8
BEFORE RIDING9
Are You Ready to Ride?10
Is Your Motorcycle Ready to Ride?.....11
Pre-ride Inspection.....11
BASIC OPERATING INSTRUCTIONS13
Safe Riding Precautions.....14
Side Stand14
Tripmeter.....14
Starting & Stopping the Engine15
Preparation.....15
Fuel Valve15
Starting Procedure15
Flooded Engine.....16
How to Stop the Engine.....16
Shifting Gears.....17
Braking18
Parking19
Post-ride Inspection.....20
Brake-in Guidelines21

SERVICING YOUR HONDA.....23
<i>Before You Service Your Honda</i>
The Importance of Maintenance24
Maintenance Safety25
Important Safety Precautions.....25
Maintenance Schedule26
General Competition Maintenance29
Before & After Competition Maintenance.....33
Between Motos & Practice Maintenance33
After Competition Maintenance33
<i>Service Preparations</i>
Maintenance Component Locations.....35
Seat Removal36
Fuel Tank Removal37
Subframe Upright Position.....39
<i>Service Procedures</i>
<u>Fluids & Filters</u>
Fuel System.....41
Engine Oil43
Transmission Oil46
Coolant48
Air Cleaner.....51
Crankcase Breather53
<u>Engine</u>
Throttle54
Clutch System56
Hot Start Lever.....60
Spark Plug61
Exhaust Pipe/Muffler62
Spark Arrester.....65
Valve Clearance.....66
Piston/Piston Rings/Piston Pin.....74

<u>Chassis</u>
Suspension.....82
Front Suspension Inspection.....82
Rear Suspension Inspection.....83
Recommended Fork Oil.....84
Fork Oil Change84
Brakes.....86
Wheels.....90
Tires & Tubes91
Side Stand.....93
Drive Chain94
Additional Maintenance Procedures97
<u>Electrical</u>
Battery99
Headlight & Taillight101
Appearance Care102
ADJUSTMENTS FOR COMPETITION ...105
Front Suspension Adjustments.....106
Rear Suspension Adjustments120
Suspension Adjustments for Track
Conditions124
Suspension Adjustment Guidelines.....125
Carburetor Adjustment & Tuning Tips128
Chassis Adjustments.....135
Gearing136
Tire Selection for Track Conditions.....137
Personal Fit Adjustments138
TIPS139
Transporting Your Motorcycle140
Storing Your Honda.....141
You & the Environment143
Troubleshooting.....144
TAKING CARE OF THE UNEXPECTED145
If a Fuse Blows146
If Your Battery Is Low (or Dead).....147

TECHNICAL INFORMATION	149
Vehicle Identification	150
Specifications	151
Torque Specifications	154
High Altitude Carburetor Adjustment	157
Emission Control Systems	158
Oxygenated Fuels.....	160
Competition Logbook	161
Optional Parts List	163
Spare Parts & Equipment.....	164
Wiring Diagram.....	165
CONSUMER INFORMATION.....	167
Authorized Manuals	168
Warranty Coverage.....	169
Warranty Service	170
Contacting Honda.....	171
Your Honda Dealer.....	172
The Honda Rider's Club (USA only)	173
TABLE OF CONTENTS.....	174
INDEX.....	176
QUICK REFERENCE	

Index

A

accessories4
adjustments,
 chassis135
 control freeplay54,56,60,86
 for competition105
 gearing136
 high altitude carburetor157
 idle speed134
 personal fit138
 suspension, front106
 suspension, rear120
 suspension, track conditions124
 tire selection92
after competition maintenance33
air cleaner51
air pressure,
 front suspension106
 tires91
apparel, protective2
appearance care102
authorized manuals168

B

basic operation13
battery99
before riding9
between motos & practice maintenance33
brakes,
 fluid level87
 lever, front adjustment86
 pad wear89
 pedal height86
break-in guidelines21

C

capacity, fuel41
carburetor,
 assembly133
 circuit functions128
 components128
 disassembly131
 high altitude adjustment157
 idle speed134
 removal130
care, appearance102
chain drive94
chassis adjustments135
choke knob15
cleaner, air51
cleaning, appearance care102
clutch system, adjustment56
consumer information167
competition logbook161
contacting Honda171
controls, operating7
coolant48
cylinder removal76

D

damping adjustments,
 front106
 rear121
dealer, your Honda172
diagram, wiring165
drive chain94

E

engine,
 flooded16
 idle speed134
 number150
 pinging41
 starting15
 stop button16
 stopping16
 won't start144
exhaust pipe,
 removal64
 installation64
 environment, protecting143

F

filter,
 air51
 oil44
flooded engine, starting16
fork,
 front suspension adjustment106
 front suspension inspection82
 oil recommendation84
front brake lever adjustment86
front suspension disassembly107
fuel,
 line41
 filter42
 recommendation41
 refueling41
 system41
 oxygenated160
 tank capacity41
 tank removal37
 valve15

G

gap, spark plug.....61
gasoline41
gearing136
guidelines, suspension adjustment.....125

H

handlebar inspection97
high altitude carburetor adjustment157
Honda,
 contacting.....171
 Rider’s Club.....173
 service manual168
 your dealer172

I

identification, vehicle150
idle speed, engine134
inspection, pre-ride11

L

labels, safety5
logbook, competition161

M

maintenance,
 after competition.....33
 before & after competition33
 between motos & practice33
 component locations35
 general competition29
 importance24
 safety.....25
 schedule27,28
manual, service168
modifications4
muffler,
 removal62
 installation63

O

oil,
 engine.....43
 fork.....84
 transmission46
operating controls7
operation component locations8
optional parts list163
 sprockets163
oxygenated fuels160

P

pads, brake89
parts, optional163
personal fit adjustments138
pinging, engine41
plug, spark.....61
pre-load, rear suspension120
pre-ride inspection11
protective apparel.....2

R

rear suspension inspection83
Rider’s Club Honda173
riding,
 apparel2
 basic operation.....13
 before9
 important safety information2
 safety precautions2

S

safety,
 a few words about.....Safety Messages
 important information.....2
 important precautions2
 labels5
 maintenance25
 riding precautions14
schedule, maintenance27,28
seat removal36
serial numbers.....150
service manuals.....168
side stand14
spare parts164
spark arrester.....65
spark knock.....41
spark plug.....61
specifications151-153
spring pre-load, rear suspension120
starting,
 engine.....15
 troubleshooting144
steering head bearing inspection97
stopping engine.....16
storage141
subframe.....39

(cont’d)

Index

suspension,	
front	82
rear	83
suspension adjustment,	
for track conditions.....	124
front	106
guidelines.....	125
rear	120

T

transmission oil.....	46
tuning tips	128
throttle,	
freeplay	54
inspection.....	55
tires,	
air pressure.....	91
inspection.....	91
replacement.....	92
tools.....	164
torque specifications.....	98,154-156
transporting	140
tripmeter.....	14
troubleshooting	144
tubes, replacing	91

V

valve, fuel	15
valve clearance.....	66
vehicle identification no. (VIN)	150

W

warranty,	
coverage.....	169
service.....	170
washing your motorcycle.....	102
weight limit.....	3
wheels	90
wiring diagram.....	165

Quick Reference

The following is a brief, but important collection of information you need to know about your Honda. You'll also find space to record important notes.

How To Avoid Costly Repairs

The engine of your Honda can be the most expensive component to repair. Proper maintenance, especially the use of the recommended fluids and filters, prevents premature wear and damage.

Frequent causes of costly engine repairs are:

- Transmission oil & engine oil: insufficient quantity, improper oil.
- Air cleaner: dirty, leaking because of improper installation (poor seal).

Record important information here:

VIN	
Engine No.	
Owner's:	
Name	
Address	
City/State	
Phone	
Dealer's:	
Name	
Address	
City/State	
Phone	
Service Mgr.	

Maintenance	The maintenance schedule (pages 27-28) lists service frequencies for: about 2.5 hours, about 7.5 hours, about 15.0 hours, about 22.5 hours, and about 30.0 hours.					
Pre-ride Inspection	Check the items listed on the Pre-ride Inspection checklist each time before you ride (page 11).					
Fuel tank Capacity	unleaded gasoline, pump octane number of 91 or higher tank: 2.19 US gal (8.3 ℓ), reserve: 0.40 US gal (1.5 ℓ)					
Engine oil	Pro Honda GN4 4-stroke oil, or an equivalent.					
Transmission oil	Pro Honda GN4 4-stroke oil or an equivalent.					
Tires	Front	80/100 – 21 51 M		Rear	100/100 – 18 59 M	
		DUNLOP	D742F		DUNLOP	D756
	Type	bias-ply, tube				
Tire Pressure (cold)	Front: 15 psi (100 kPa, 1.0kgf/cm ²) Rear: 15 psi (100 kPa, 1.0kgf/cm ²)					
Spark Plug	standard: IMR8C-9H (NGK) or VUH24D (DENSO) optional: IMR9C-9H (NGK) or VUH27D (DENSO)					
Coolant	ethylene glycol antifreeze (silicate-free) for aluminum engines in 50/50 solution with Pro Honda HP Coolant or equivalent distilled water.					
Drive Chain Size/link	DID 520MXV/116					