

This manual should be considered a permanent part of the ATV and should remain with the ATV when it is resold.

This Owner's Manual covers the TRX680FA and TRX680FGA models. You may find descriptions of equipment and features that are not on your particular model. All illustrations are based on the TRX680FGA model.

This publication includes the latest production information available before printing. Honda Motor Co., Ltd. reserves the right to make changes at any time without notice and without incurring any obligation.

No part of this publication may be reproduced without written permission.

The vehicle pictured on the front cover may not match your vehicle.

© Honda Motor Co., Ltd. 2006

**2007
Honda TRX680FA/FGA
FOURTRAX RINCON/with GPScape
OWNER'S MANUAL**

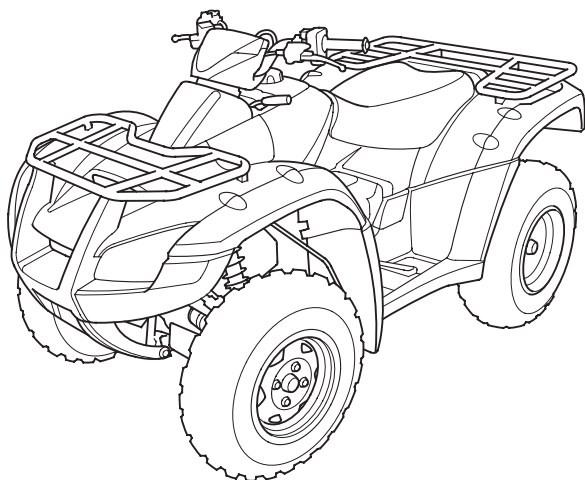

FOR OFF-ROAD USE ONLY

This vehicle is designed and manufactured for off-road use only.
USA only:

It conforms to US EPA Noise Emission regulations, but does not conform to Federal Motor Vehicle Safety Standards or US EPA On Highway Exhaust Emission regulations, and operation on public streets, roads, or highways is illegal. The vehicle is equipped with a USDA qualified spark arrester. Obey local laws and regulations.

It conforms to US EPA and California exhaust emission regulations for ATVs.

Introduction

Congratulations on choosing your Honda ATV.

When you own a Honda, you're part of a worldwide family of satisfied customers — people who appreciate Honda's reputation for building quality into every product.

Your Honda was designed as a recreational ATV for off-road use by one rider only.

Before riding, take time to get acquainted with your ATV and how it works. To protect your investment, we urge you to take responsibility for keeping your ATV well maintained. Scheduled service is a must, of course. But it's just as important to observe the break-in guidelines, and perform all pre-ride and other periodic checks detailed in this manual.

We also recommend that you read this owner's manual before you ride. It's full of facts, instructions, safety information, and helpful tips. To make it easy to use, the manual contains a detailed list of topics at the beginning of each section, and both an in-depth table of contents and an index at the back of the book.

As you read this manual, you will find information that is preceded by a **NOTICE** symbol. This information is intended to help you avoid damage to your Honda, other property, or the environment.

Read the Warranties Booklet (page 251) thoroughly so you understand the coverages that protect your new Honda and are aware of your rights and responsibilities.

Whenever you ride, tread lightly. By staying on established trails and riding only in approved areas, you help protect the environment and keep off-road riding areas open for the future.

Introduction

If you have any questions, or if you ever need special service or repairs, remember that your Honda dealer knows your ATV best and is dedicated to your complete satisfaction.

Please report any change of address or ownership to your Honda dealer so we will be able to contact you concerning important production information.

You may also want to visit our website at www.honda.com.

Happy riding!

California Proposition 65 Warning

WARNING: This product contains or emits chemicals known to the State of California to cause cancer and birth defects or other reproductive harm.

A Few Words About Safety

Your safety, and the safety of others, is very important. And operating this ATV safely is an important responsibility.

To help you make informed decisions about safety, we have provided operating procedures and other information on labels and in this manual. This information alerts you to potential hazards that could hurt you or others.

Of course, it is not practical or possible to warn you about all hazards associated with operating or maintaining an ATV. You must use your own good judgment.

You will find important safety information in a variety of forms, including:

Safety Labels — on the ATV.

Safety Messages — preceded by a safety alert symbol  and one of three signal words: **DANGER**, **WARNING**, or **CAUTION**.

A Few Words About Safety

These signal words mean:

 **DANGER**

You **WILL** be **KILLED** or **SERIOUSLY HURT** if you don't follow instructions.

 **WARNING**

You **CAN** be **KILLED** or **SERIOUSLY HURT** if you don't follow instructions.

 **CAUTION**

You **CAN** be **HURT** if you don't follow instructions.

Safety Headings — such as Important Safety Reminders or Important Safety Precautions.

Safety Section — such as ATV Safety.

Instructions — how to use this ATV correctly and safely.

This entire manual is filled with important safety information — please read it carefully.

Contents

These pages give an overview of the contents of your owner's manual. The first page of each section lists the topics covered in that section.

ATV Safety	1
Important safety information you should know, plus a look at the safety-related labels on your ATV.	
Instruments & Controls.....	9
The location and function of indicators and controls on your ATV and operating instructions for various controls and features.	
GPScape System (TRX680FGA only)	45
Instructions for use of your ATV Navigation System.	
Before Riding.....	73
The importance of wearing a helmet and other protective gear, how to make sure you and your ATV are ready to ride, and important information about loading.	
Basic Operation & Riding	89
How to start and stop the engine, shift gears, and brake. Also, riding precautions.	

Contents

Servicing Your Honda	125
Why your ATV needs regular maintenance, what you need to know before servicing your Honda, an owner maintenance schedule, and instructions for specific maintenance and adjustment items.	
Tips	201
How to store and transport your ATV and how to be an environmentally-responsible rider.	
Taking Care of the Unexpected	211
What to do if you have a flat tire, your engine won't start, etc.	
Technical Information	233
ID numbers, technical specifications, and other technical facts.	
Consumer Information	247
Information on warranties, emission controls, how to get Honda service manuals.	
Table of Contents	256
Sequential listing of topics in this owner's manual.	
Index	264
Quick Reference	
Handy facts about fuel, engine oil, tire sizes, and air pressures.	

ATV Safety

This section presents some of the most important information and recommendations to help you ride your ATV safely. Please take a few moments to read these pages. This section also includes information about the location of safety labels on your ATV.

Important Safety Information	2
Safety Labels.....	5

Important Safety Information

Your ATV can provide many years of service and pleasure — if you take responsibility for your own safety and understand the challenges you can meet while riding.

There is much that you can do to protect yourself when you ride. You'll find many helpful recommendations throughout this manual. The following are a few that we consider most important.

Follow the Age Recommendation

The minimum recommended age for this ATV model is 16. Children under age 16 should never operate this vehicle.

Always Wear a Helmet

It's a proven fact: helmets significantly reduce the number and severity of head injuries. So always wear an approved motorcycle helmet. We also recommend that you wear eye protection, sturdy boots, gloves, and other protective gear (page 74).

Never Carry a Passenger

Your ATV is designed for one person only. There are no handholds, footrests, or seat for a second person — so never carry a passenger. A passenger could interfere with your ability to move around to maintain your balance and control of the ATV.

Important Safety Information

Ride Off-Road Only

Your ATV is designed and manufactured for off-road use only. The tires are not made for pavement, and the ATV does not have turn signals and other features required for use on public roads. If you need to cross a paved or public road, get off and walk your ATV across.

Take Time to Learn & Practice

Even if you have ridden other ATVs, take time to become familiar with how this ATV works and handles. Practice in a safe area until you build your skills and get accustomed to the ATV's size and weight.

Because many accidents involve inexperienced or untrained riders, we urge all riders to take a training course approved by the ATV Safety Institute (ASI). See page 76.

Contact an authorized ATV dealer or call 1-800-887-2887 (USA only) to find out about the training courses nearest you.

Be Alert for Off-Road Hazards

The terrain can present a variety of challenges when you ride off-road. Continually “read” the terrain for unexpected turns, drop-offs, rocks, ruts, and other hazards. Always keep your speed low enough to allow time to see and react to hazards.

Important Safety Information

Ride within Your Limits

Pushing limits is another major cause of ATV accidents. Never ride beyond your personal abilities or faster than conditions warrant. Remember that alcohol, drugs, fatigue, and inattention can significantly reduce your ability to make good judgments and ride safely.

Don't Drink and Ride

Alcohol and riding don't mix. Even one drink can reduce your ability to respond to changing conditions, and your reaction time gets worse with every additional drink. So don't drink and ride, and don't let your friends drink and ride either.

Keep Your Honda in Safe Condition

It's important to keep your ATV properly maintained and in safe riding condition. Having a breakdown can be difficult, especially if you are stranded off-road far from your base. To help avoid problems, inspect your ATV before every ride and perform all recommended maintenance.

Safety Labels

Your ATV comes with a hang tag and several labels containing important safety information. Anyone who rides the vehicle should read and understand this information before riding.

The labels should be considered permanent parts of the vehicle. If a label comes off or becomes hard to read, contact your Honda dealer for replacements.

Safety Labels

USA only

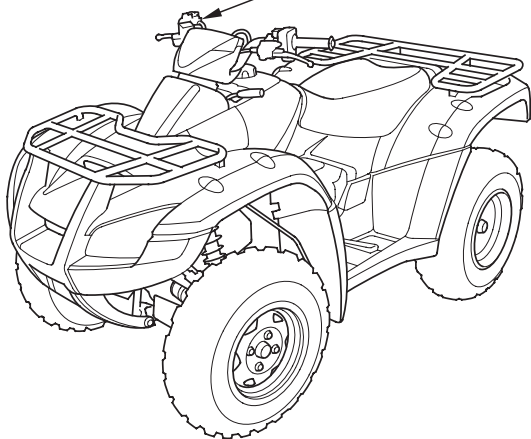
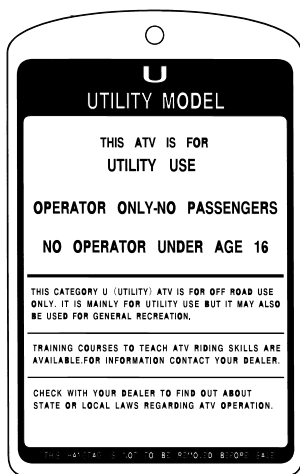
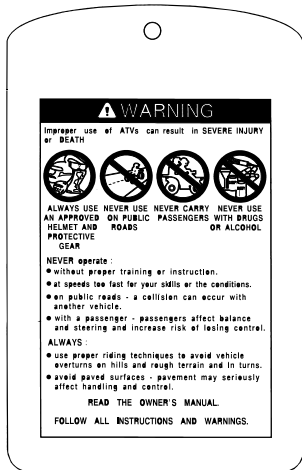

Safety Labels

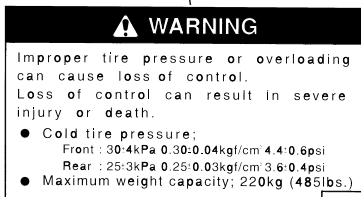
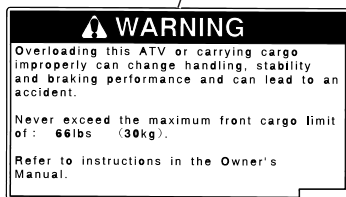
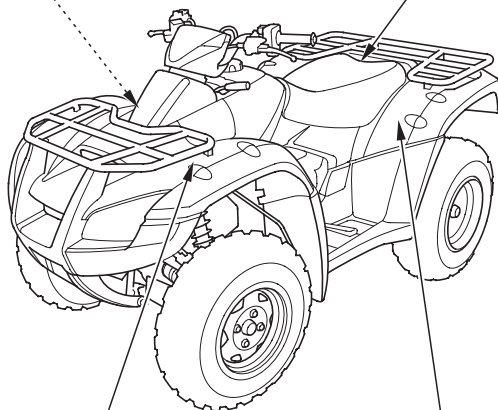

Safety Labels

WARNING



Operating this ATV if you are under the age of 16 increases your chance of severe injury or death.

NEVER operate this ATV if you are under age 16.

BRAKING INFORMATION

With four-wheel drive operating any brake control causes braking at both the front and rear wheels. For detailed braking information, refer to the Owner's Manual.

WARNING

Overloading this ATV or carrying cargo improperly can change handling, stability and braking performance and can lead to an accident.

Never exceed the maximum rear cargo limit (combined weight on the rear rack and in the storage area) of: 133lbs (60kg).

Refer to instructions in the Owner's Manual.

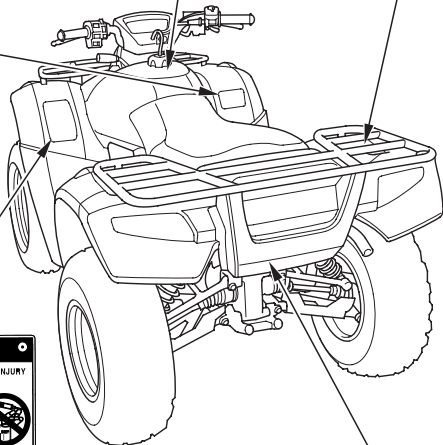

WARNING

Improper use of ATVs can result in SEVERE INJURY or DEATH.



ALWAYS USE HELMET AND PROTECTIVE GEAR. NEVER USE ATVs ON PUBLIC ROADS. NEVER CARRY PASSENGERS OR ALCOHOL. NEVER USE ATVs ON ALCOHOL.

NEVER operate:

- without proper training or instruction.
- at speeds too fast for your skills or the conditions.
- on public roads - a collision can occur with another vehicle.
- with a passenger - passengers affect balance and steering and increase risk of losing control.

ALWAYS:

- use proper riding techniques to avoid vehicle overturns on hills and rough terrain and in turns.
- avoid paved surfaces - pavement may seriously affect handling and control.

READ THE OWNER'S MANUAL.

FOLLOW ALL INSTRUCTIONS AND WARNINGS.

WARNING

Towing an improperly loaded trailer can cause loss of control.

- Read owner's manual.
- Tow weight limit : 3776N (385kgf) 850lbs
- Tongue weight : 137N (14kgf) 30lbs

Instruments & Controls

This section shows the location of all indicators and controls you would normally use before or while riding your ATV.

The items listed on this page are described in this section. Instructions for other components are presented in other sections of this manual where they will be most useful.

Operation Component Locations	11
Indicators & Displays.....	14
Multi-function Display.....	19
Drive Mode Indicator.....	20
Gear Position Indicator.....	21
Oil Change Indicator.....	22
Odometer.....	23
Tripmeter.....	23
Hourmeter	25
Digital Clock.....	26
Fuel Gauge.....	29

(cont'd)

Instruments & Controls

Controls & Features	30
Ignition Switch	30
Shift Lever	31
Drive Mode Select Switch.....	32
2WD/4WD Select Switch	33
Start Button	34
Engine Stop Switch.....	34
Headlight Switch.....	35
Headlight Dimmer Switch.....	35
Recoil Starter.....	36
Throttle Lever	37
Gearshift Switch.....	38
Front Brake Lever	39
Rear Brake Lever	39
Rear Brake Pedal.....	39
Parking Brake.....	40
Flag Pole Bracket	41
Accessory Socket	42

Operation Component Locations

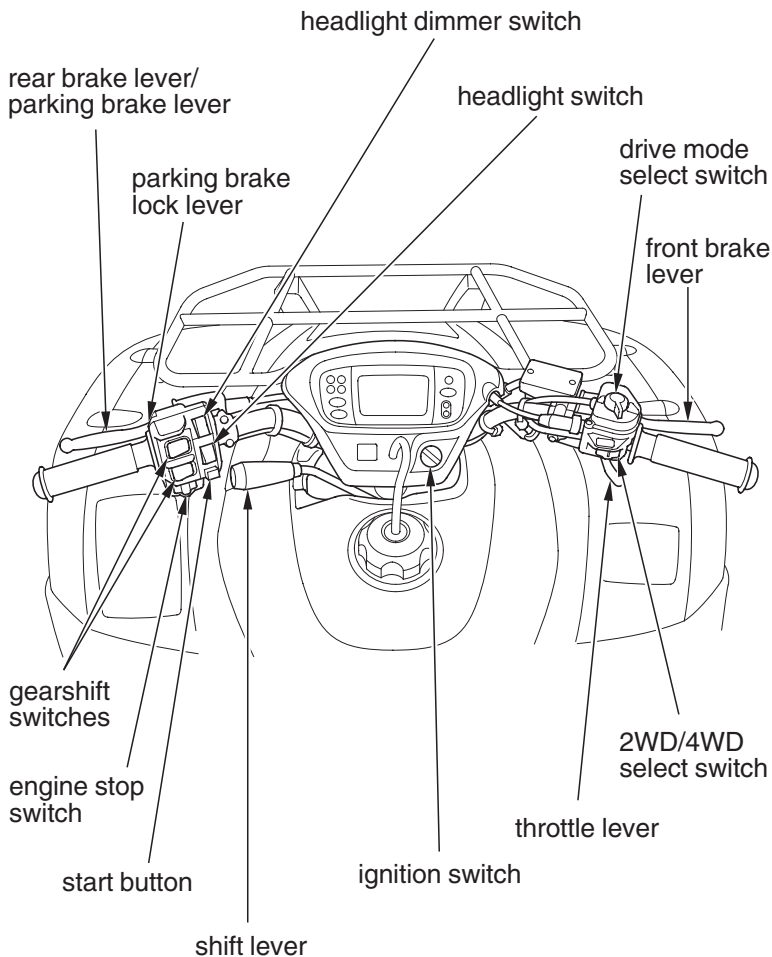

Operation Component Locations

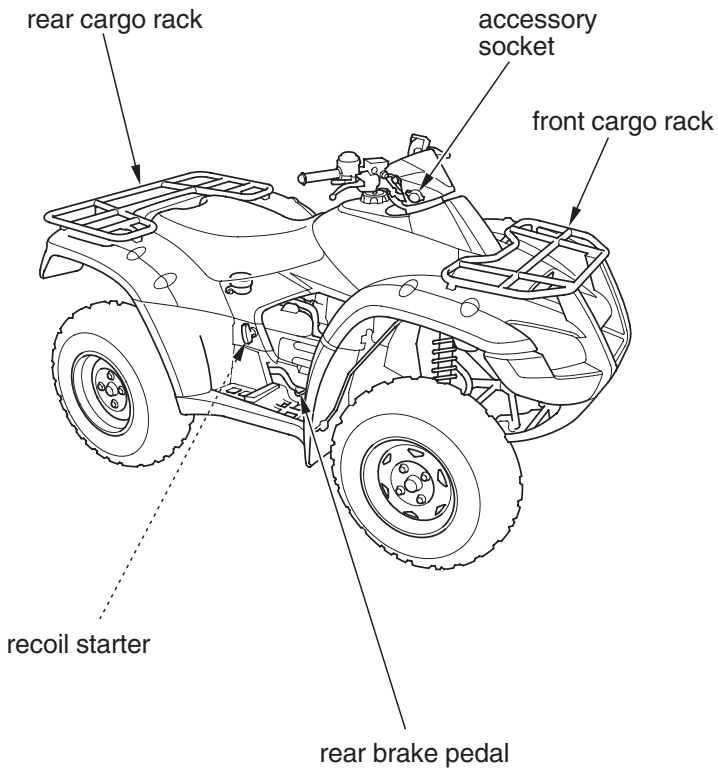

Operation Component Locations

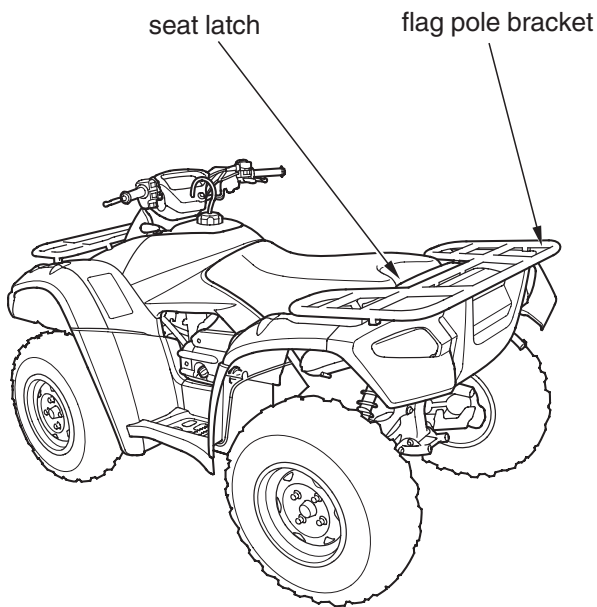

Indicators & Displays

The indicators and displays on your ATV keep you informed, alert you to possible problems, and make your riding safer and more enjoyable. Refer to the indicators frequently. Their functions are described on the following pages.

TRX680FA

TRX680FGA

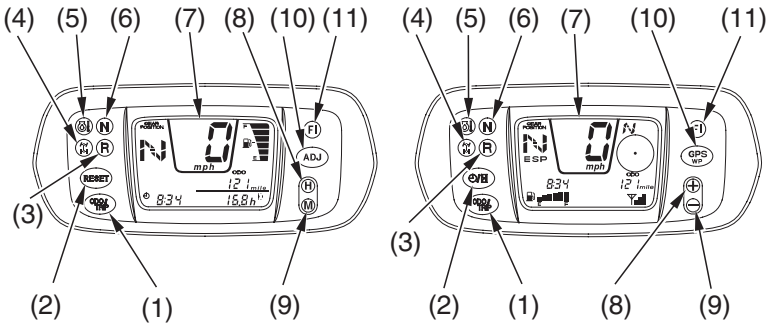

- (1) odometer/tripmeter select button
- (2) RESET button
- (3) reverse indicator
- (4) 4WD indicator
- (5) high oil/coolant temperature indicator
- (6) neutral indicator
- (7) multi-function display
- (8) hour select button
plus button (TRX680FGA)
- (9) minute select button
minus button (TRX680FGA)
- (10) ADJ button
GPS/WP button (TRX680FGA)
- (11) PGM-FI indicator

Indicators & Displays

Lamp Check

The high oil/coolant temperature indicator, 4WD indicator, neutral indicator, reverse indicator and PGM-FI indicator comes on when you turn the ignition switch ON (I) so you can check that it is working.

The indicator remains on until after the engine is started.

This indicator is identified in the table on page 16 with the words: *Lamp Check*.

When applicable, the reverse or neutral indicators come on when you turn the ignition switch ON (I) and remain on until you shift out of reverse or neutral.

If one of these indicators does not come on when it should, have your Honda dealer check for problems.

Display Check

When the ignition switch is turned ON (I), the multi-function display (1) will temporarily show all the modes and digital segments so you can make sure the liquid crystal display is functioning properly.

The displays are identified in the table on page 16 with the words: *Display Check*.

If any part of these displays does not come on when it should, have your Honda dealer check for problems.

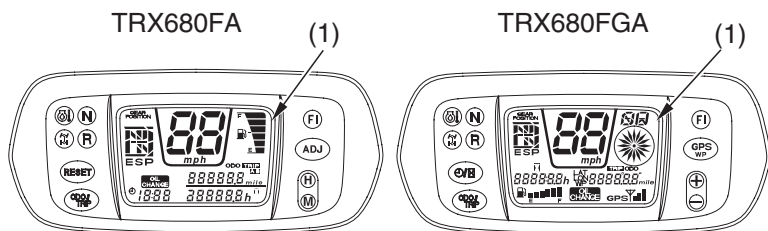

(1) multi-function display

Indicators & Displays

1	Odometer/tripmeter select button	Selects display of the odometer or tripmeter A or tripmeter B (page 24). This button also used to reset the oil change indicator (page 22).
	Odometer/tripmeter select button (TRX680FGA)	Selects display of the odometer or tripmeter. Resets the tripmeter to zero (0) (page 23). This button also used to reset the oil change indicator (page 22).
2	RESET button	Resets the tripmeter to zero (0) (page 24). This button also used to reset the oil change indicator (page 22).
	Hourmeter/digital clock select button (TRX680FGA)	Selects display of the hourmeter or digital clock (pages 25 , 27).
3	Reverse indicator	Lights when the transmission is in reverse. <i>Lamp check.</i>
4	4WD indicator	Lights when the drive mode is in the 4WD mode. The 4WD indicator blinks if there is a possible problem with the 2WD/4WD select system. See your Honda dealer as soon as possible. <i>Lamp check.</i>
5	High oil/coolant temperature indicator	Lights when engine oil and/or coolant temperature is high enough to adversely affect the service life of the engine. If the high oil/coolant temperature indicator comes on while you are riding, immediately bring the vehicle to a stop, turn the engine off and let it cool. See page 222. <i>Lamp Check.</i>

Indicators & Displays

6	Neutral indicator	Lights when the transmission is in neutral. <i>Lamp Check</i> .
7	Multi-function display	The display includes the following functions. <i>Display Check</i> .
	Drive mode indicator	Shows the driving mode (page 20).
	Gear position indicator	Shows the gear position (page 21).
	Speedometer	Shows riding speed.
	Fuel gauge	Shows approximate fuel supply available (page 29).
	Oil change indicator	Lights when specified maintenance interval for engine oil change is reached (page 22).
	Odometer	Shows accumulated mileage (page 23).
	Tripmeter	Shows mileage per trip (page 23).
	Hourmeter	Shows hours and tenths of hours of engine operation (page 25).
Digital clock	Shows the time (hours and minutes) (page 26).	

Indicators & Displays

8	Hour select button	Advances the hour displayed by the digital clock (page 26).
	Plus button (TRX680 FGA)	Advances the latitude and longitude when in the GPS mode.
9	Minute select button	Advances the minutes displayed by the digital clock (page 26).
	Minus button (TRX680 FGA)	Advances the latitude and longitude when in the GPS mode.
10	ADJ button	Used to set the digital clock (page 26).
	GPS/WP button (TRX680 FGA)	This button is used to select the GPS navigation mode and input a waypoint or to erase waypoint data.
11	PGM-FI indicator	Lights when there is any abnormality in the PGM-FI (Programmed Fuel Injection) system. Should also light for a few seconds and then go off when the ignition switch is turned ON and use the start button. If the indicator comes on at any other time, reduce speed and take your vehicle to a Honda dealer as soon as possible. <i>Lamp Check.</i>

Indicators & Displays

Multi-function Display

The multi-function display (1) includes the following functions:

Drive mode indicator	Speedometer	Digital clock
Gear position indicator	Odometer	Hourmeter
Oil change indicator	Tripmeter	Fuel gauge

The digital clock will reset if the battery is disconnected.

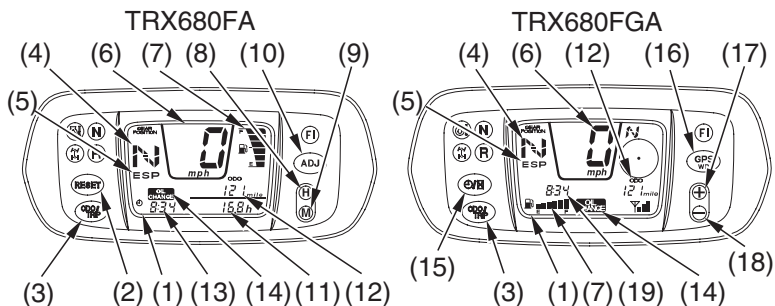

- (1) multi-function display
- (2) RESET button (TRX680FA)
- (3) odometer/tripmeter select button
- (4) gear position indicator
- (5) drive mode indicator
- (6) speedometer
- (7) fuel gauge
- (8) hour select button (TRX680FA)
- (9) minute select button (TRX680FA)
- (10) ADJ button (TRX680FA)
- (11) hourmeter (TRX680FA)

- (12) odometer/tripmeter
- (13) digital clock (TRX680FA)
- (14) oil change indicator
- (15) digital clock/hourmeter select button (TRX680FGA)
- (16) GPS/WP button (TRX680FGA)
- (17) puls button (TRX680FGA)
- (18) minus button (TRX680FGA)
- (19) digital clock/hourmeter (TRX680FGA)

Indicators & Displays

Drive Mode Indicator

The drive mode indicator (1) shows the selected drive mode when the ignition switch is in the ON (I) position.

The drive mode indicator (1) displays ESP when the manual shift (ESP) mode is selected. The ESP display vanishes when the automatic shift (AUTO) mode is selected.

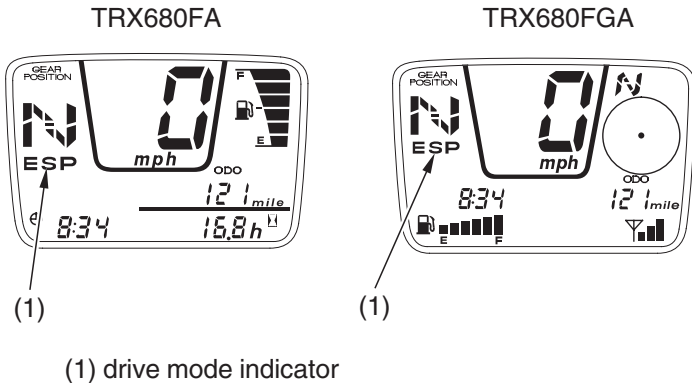

Indicators & Displays

Gear Position Indicator

The gear position indicator (1) shows the gear position when the ignition switch is in the ON (I) position.

The indicator displays: N for neutral, R for reverse, D for drive, and 1 – 3 for the three forward speed positions in the ESP mode.

“- -” will be displayed on the gear position indicator when the transmission is not shifted into gear properly. Before riding, check that the gear position is displayed on the gear position indicator properly.

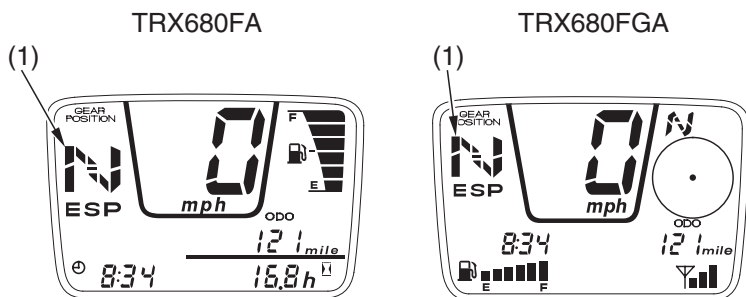

(1) gear position indicator

Indicators & Displays

Oil Change Indicator

The oil change indicator (1) appears in the display when the mileage or operating hours on your ATV approaches the oil change interval specified on the maintenance schedule.

Reset the indicator after each oil change.

(For TRX680FA)

To reset the indicator, press and hold both the odometer/tripmeter select button (2) and RESET button (3) for more than 2 seconds. The indicator will disappear.

(For TRX680FGA)

To reset the indicator, press and hold both the odometer/tripmeter select button (2) and digital clock/hourmeter select button (4) for more than 2 seconds. The indicator will disappear.

If the oil is changed before the oil change indicator appears, be sure to reset the oil change indicator after changing the oil. The indicator will appear for 2 seconds, then disappear. This means the indicator is reset.

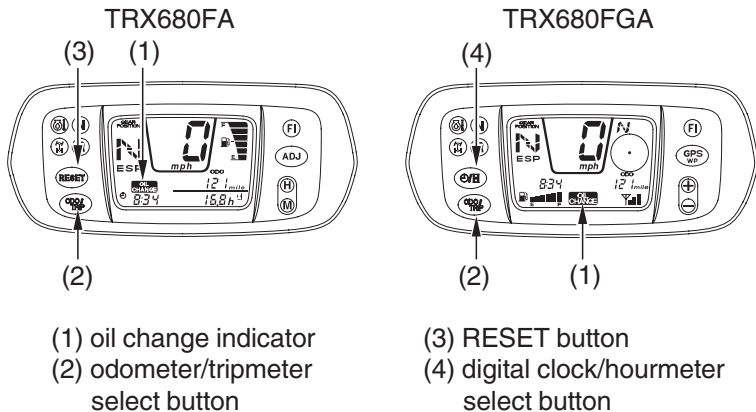

Indicators & Displays

Odometer

When selected, the odometer (1) registers total distance traveled in miles while the ignition is ON (1). To change the display from tripmeter to odometer, press and release the Odometer/Tripmeter select button (2).

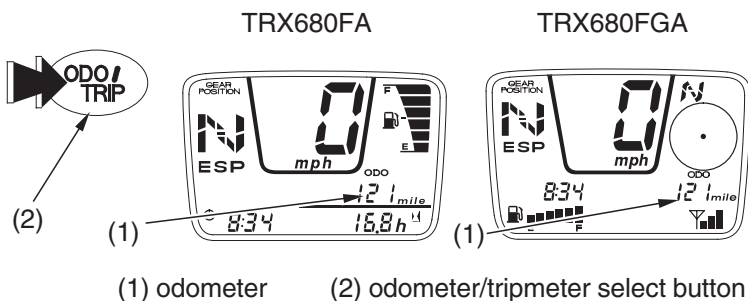

Tripmeter

(For TRX680FGA)

When selected, the tripmeter (3) shows mileage per trip while the ignition is ON (1). To change the display from odometer to tripmeter, press and release the Odometer/Tripmeter select button (2). To reset the tripmeter to zero, press the Odometer/Tripmeter select button and hold it in for at least two seconds.

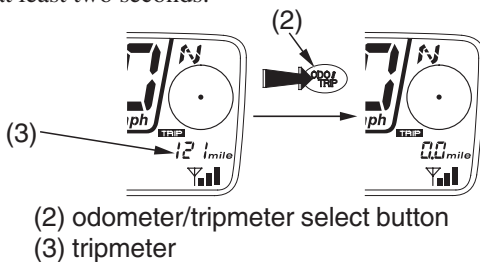

(cont'd)

Indicators & Displays

(For TRX680FA)

The tripmeter has two sub modes, A (4) and B (5).

To change the display from tripmeter A or tripmeter B to odometer, press and release the odometer/tripmeter select button (2).

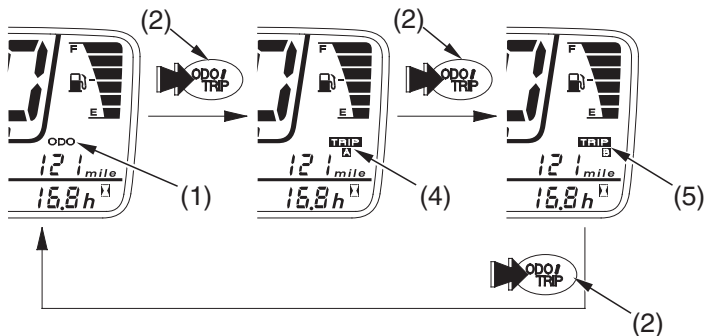

(4) tripmeter A

(5) tripmeter B

To reset the tripmeter to zero, press and hold the RESET button (6) for more than 2 seconds with the display in the tripmeter A or tripmeter B mode.



(6) RESET button

Indicators & Displays

Hourmeter

The hourmeter (1) shows accumulated hours while the ignition is ON (I). The hourmeter provides accurate service period information for initial and regular maintenance.

TRX680FA

TRX680FGA

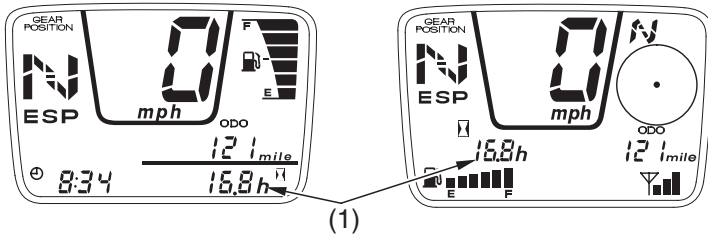

(1) hourmeter

(For TRX680FGA)

To change the display from the digital clock to the hourmeter, press and release the hourmeter/digital clock select button (2). The hourmeter mark (3) will appear.

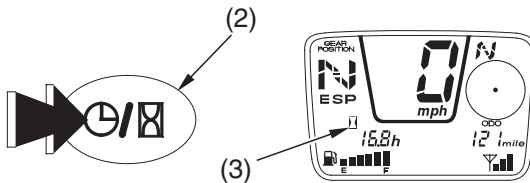

(2) hourmeter/digital clock select button

(3) hourmeter mark

Indicators & Displays

Digital Clock

Shows hour and minute while the ignition is ON (I).

To adjust the time, proceed as follows.

(For TRX680FA)

1. Turn the ignition switch ON (I).
2. To select the adjust mode, push the ADJ button (1) once.
3. To advance the hour display one unit at a time, press and release the hour select button (2).
To advance the hour display automatically, press and hold the hour select button. After 2 seconds, the hour display will begin advancing. Release the button when the display reaches the desired hour.
4. To advance the minute display one unit at a time, press and release the minute select button (3).

To advance the minute display automatically, press and hold the minute select button. After 2 seconds, the minute display will begin advancing. Release the button when the display reaches the desired minute.

To zero the minute display, press and hold both the hour and minute select buttons simultaneously for 2 seconds.

5. Press the ADJ button when the display reaches the desired minute.
The display will stop flashing.

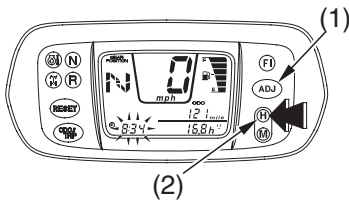

- (1) ADJ button
(2) hour select button

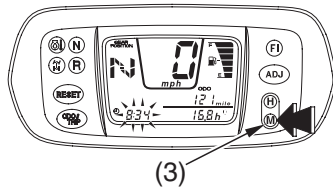

- (3) minute select button

Indicators & Displays

(For TRX680FGA)

1. Turn the ignition switch ON (I).
 - To change the display from hourmeter to digital clock, press and release the hourmeter/digital clock select button (1).
2. Press and hold the hourmeter/digital clock select button for more than 2 seconds. The clock will be set in the adjust mode with the hour display flashing.
3. To advance the hour display one unit at a time, press and release the plus button (2) or minus button (3).
To advance the hour display automatically, press and hold the plus button or minus button. After 2 seconds, the hour display will begin advancing. Release the button when the display reaches the desired hour.

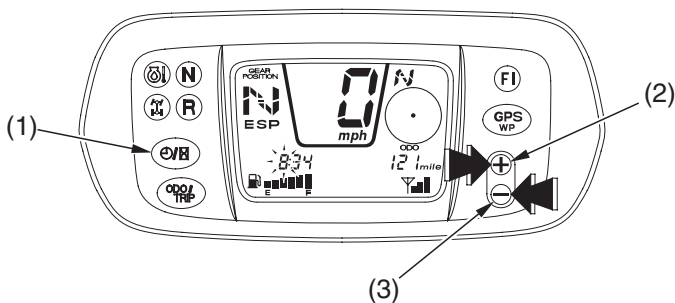

(1) hourmeter/digital clock
select button

(2) plus button

(3) minus button

(cont'd)

Indicators & Displays

4. Press the hourmeter/digital clock select button when the display reaches the desired hour appears. The minutes display will be flashing.

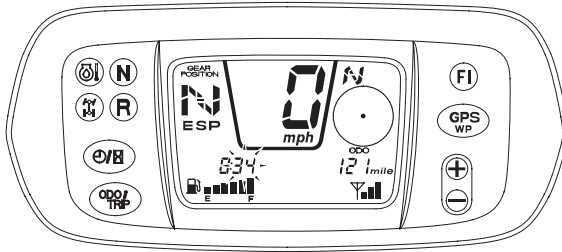

5. To advance the minute display one unit at a time, press and release the plus button or minus button.
To advance the minute display automatically, press and hold the plus button or minus button. After 2 seconds, the minute display will begin advancing. Release the button when the display reaches the desired minute.
6. Press the hourmeter/digital clock select button when the display reaches the desired minutes appears. The display will stop flashing.
 - Your ATV's digital clock has an automatic adjustment function whenever the GPS mode is selected and the system's satellite status is 3D Navigation (page 72).

Indicators & Displays

Fuel Gauge

The fuel gauge liquid crystal display (1) shows the approximate fuel supply available. The fuel tank capacity is:

4.49 US gal (17.0 ℓ)

When segment E (2) and low fuel indicator (3) flash, you should refill the tank as soon as possible. The amount of fuel remaining when the flashing starts is approximately:

1.08 US gal (4.1 ℓ)

TRX680FA

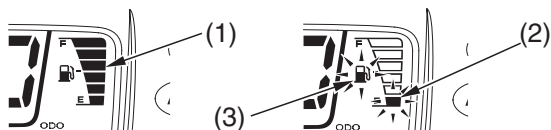

TRX680FGA

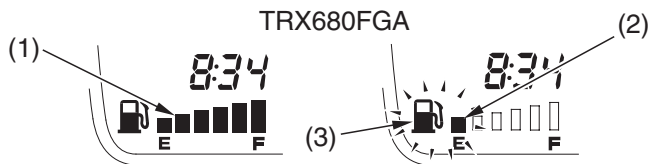

(1) fuel gauge
(2) segment E

(3) low fuel indicator

All segments will flash, when the fuel gauge function is fails. See your Honda dealer.

TRX680FA

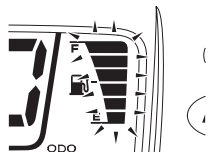

TRX680FGA

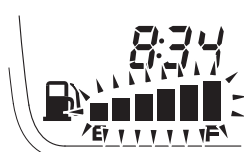

Controls & Features

Ignition Switch

The ignition switch (1) is used for starting and stopping the engine (page 96). Insert the key and turn it to the right for the ON (I) position.

Key Position	Function
ON (I)	Electrical circuits on.
OFF (O)	No electrical circuits function.

CENTER OF HANDLEBAR

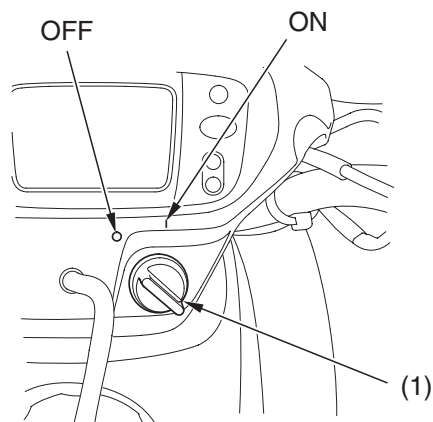

(1) ignition switch

I ON
O OFF

Controls & Features

Shift Lever

The shift lever (1) has three positions: drive (D), neutral (N), and reverse (R).

See *Shifting Gears* (page102) and *Riding in Reverse* (page108).

LEFT SIDE OF HANDLE COVER

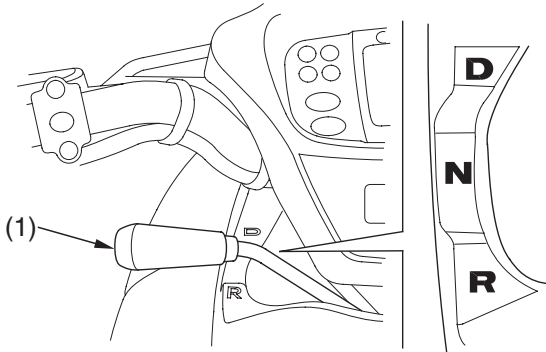

(1) shift lever

Controls & Features

Drive Mode Select Switch

The drive mode select switch (1) has two positions, AUTO and ESP. See *Shifting Gears* page 102.

RIGHT HANDLEBAR

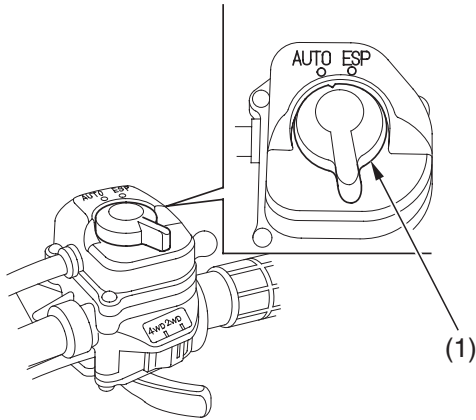

(1) drive mode select switch

Controls & Features

2WD/4WD Select Switch

Your ATV is equipped with a 2WD/4WD select switch (1), which permits a choice between the “2WD” and “4WD” drive modes. Select a drive mode that’s suitable for your riding.

The 2WD/4WD select switch is located above the throttle lever. To select the drive mode, slide the 2WD/4WD select switch to the desired position.

To check your present drive mode, look at the 4WD indicator (2).

2WD mode : the 4WD indicator goes off.

4WD mode : the 4WD indicator goes on.

4WD can only be engaged while the engine is running.

It remains engaged until the 2WD mode is selected or the engine is stopped.

Upon starting, your ATV will be in the 2WD mode, regardless of the 2WD/4WD select switch position.

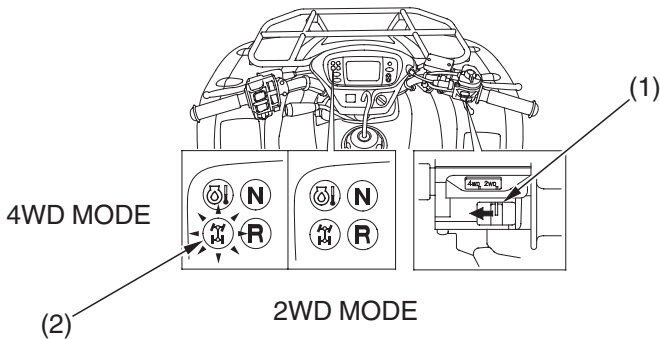

(1) 2WD/4WD select switch

(2) 4WD indicator

Controls & Features

Start Button



LEFT HANDLEBAR

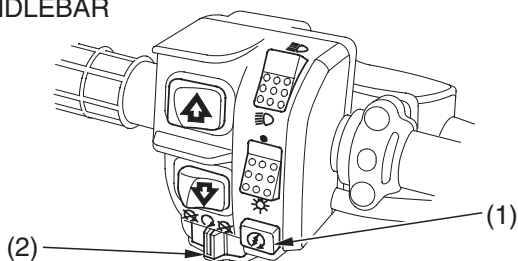

(1) start button

(2) engine stop switch

 START

 RUN



 OFF



The start button (1) is used for starting the engine. Pushing the button in starts the engine. See *Starting Procedure*, page 97.

When the start button is pushed, the starter motor will crank the engine. The starter motor will not operate if the engine stop switch is in the OFF () position when the start button is pushed.

Engine Stop Switch



The engine stop switch (2) is used to stop the engine in an emergency. To operate, slide the switch to either OFF () position. The switch must be in the RUN () position to start the engine, and it should normally remain in the RUN () position even when the engine is OFF.

If your ATV is stopped with the ignition switch ON () and the engine stop switch OFF (), the battery will discharge. Turn the ignition switch OFF () to prevent battery discharge.

Controls & Features

Headlight Switch



LEFT HANDLEBAR

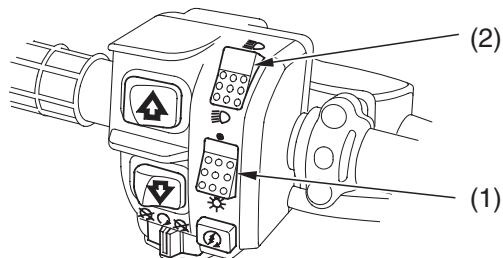

(1) headlight switch

(2) headlight dimmer switch

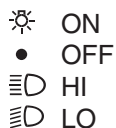

The headlight switch (1) is used to turn the headlight ON (☀) or OFF (•). To operate, turn the switch to ON (☀) or OFF (•).

Headlight Dimmer Switch



The headlight dimmer switch (2) is used to change between the high and low beams of the headlight. To operate, turn the switch to HI (≡D) for high beam, LO (≡D) for low beam.

Controls & Features

Recoil Starter

RIGHT SIDE

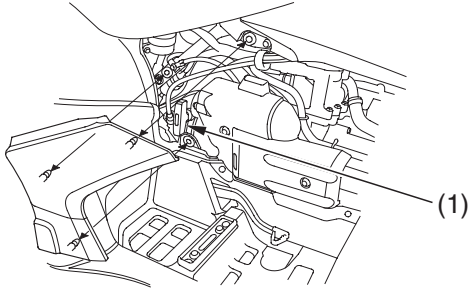

(1) recoil starter

The recoil starter (1) is used to start the engine when the battery is low.
See *Using the Recoil Starter*, page 101 .

Controls & Features

Throttle Lever

RIGHT HANDLEBAR

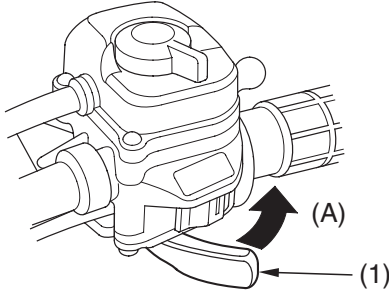

- (1) throttle lever
- (A) to open the throttle

The throttle controls engine rpm (speed). To increase engine rpm, press the throttle lever (1) with your thumb. To reduce engine rpm, release pressure on the throttle lever. The throttle will automatically return to the closed position (engine idle) when you remove your thumb.

Controls & Features

Gearshift Switch

Two gearshift switches are used in the ESP (manual shift) mode. These switches are used to select the next higher or lower gear in the transmission. To operate, press the upshift switch (1) to engage the next higher gear or press the downshift switch (2) to engage the next lower gear. See *Shifting Gears*, page 102.

LEFT HANDLEBAR

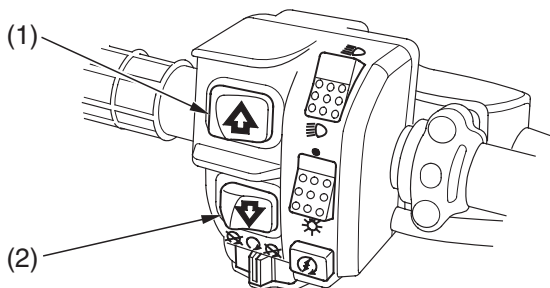

(1) upshift switch

(2) downshift switch

Controls & Features

Front Brake Lever

The front brake lever is used to slow or stop your ATV. To operate, pull the lever. For information on braking techniques, see page 110.

Rear Brake Lever

The rear brake lever is used to slow or stop your ATV. To operate, pull the lever. For information on braking techniques, see page 110.

Rear Brake Pedal

The rear brake pedal is used to slow or stop your ATV. To operate, depress the pedal. For information on braking techniques, see page 110.

Controls & Features

Parking Brake

LEFT HANDLEBAR

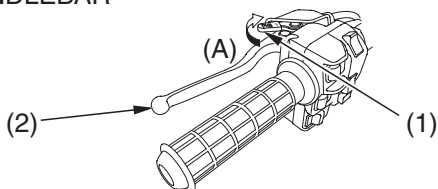

(1) lock lever

(2) rear brake lever/parking brake lever (A) to lock

The lock lever (1) on the rear brake lever/parking brake lever (2) allows it to be used as a parking brake. To operate, first squeeze the rear brake lever/parking brake lever using your left hand and then lock it with the lock lever using your right hand. See *Parking* page 124.

The brakelights are activated by applying the parking brake. When using the parking brake, be sure to turn the ignition switch OFF (○) to avoid discharging the battery.

Controls & Features

Flag Pole Bracket

RIGHT REAR

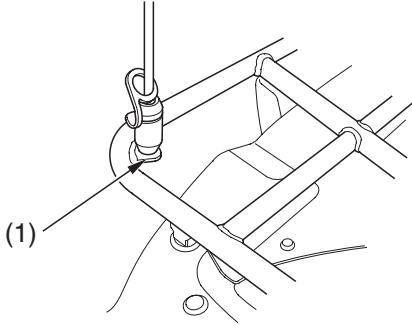

(1) flag pole bracket

Flag poles are optional equipment available from your Honda dealer. To mount a pole in the bracket (1), follow the instructions that come with the flag pole kit.

Flag poles are required in some riding areas. Check local regulations before riding.

Controls & Features

Accessory Socket

RIGHT FRONT

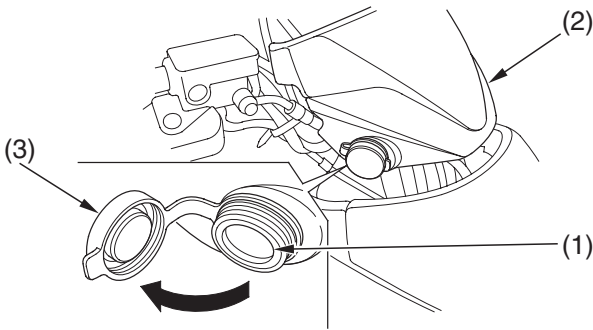

(1) accessory socket
(2) meter cover

(3) cap

The accessory socket (1) is attached to the right side of the meter cover (2). You can use the accessory socket to power a trouble light, spotlight, CB radio, or cell phone, etc.

NOTICE

Do not plug in any heat-generating accessory such as an automobile cigarette lighter because it can damage the socket.

To use the accessory socket, turn the ignition switch ON (I), start the engine. Then turn the headlights OFF (●), and open the accessory socket cap (3).

Controls & Features

Be sure the engine is on and the headlights are turned off before using the accessory socket, otherwise you may drain the battery.

The accessory socket's rated capacity is DC 12V, 120 Watts (10A) or less. If you exceed this limit, you may blow a fuse. See *If a Fuse Blows*, page 224 .

When you are done using an accessory, unplug it, and cover the socket with the cap.

Be careful not to flood this accessory socket when washing your ATV.

GPScape System (TRX680FGA only)

This section explains the GPScape navigation system. Instructions for the topics listed on this page are included.

Introduction	46
Important Safety Information	49
System Limitations.....	50
System Start-up	51
Position Fix	51
System Failure to Display a Position Fix	52
Satellite Status	54
GPS Mode	56
GPS Mode Display.....	58
Waypoint Number Display	59
Direction to Waypoint Display	60
Distance to Waypoint	62
Basic Waypoint Selection	63
Advanced Waypoint Selection.....	65
Determining the Coordinates of Your Current Position.....	69
Compass Direction Indicator.....	70
Automatic Clock Adjustment.....	72

Introduction

Any location on Earth may be described by two positioning coordinates. These two coordinates, measured by degrees, minutes, and seconds, are:

- latitude
- longitude

Latitudes are horizontal circles drawn around the Earth. The zero degree latitude (the equator) divides the globe into the Northern and Southern hemispheres.

LATITUDE

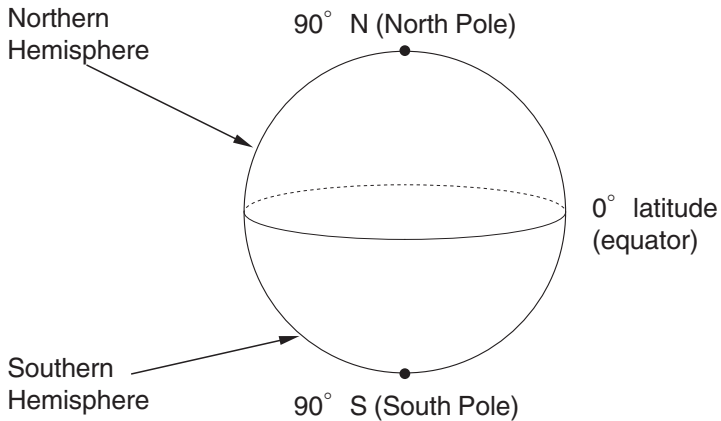

Each circle contains 360° (degree)
Each degree contains 60' (minutes)
Each minute contains 60" (seconds)

Introduction

Longitudes, also called meridians, are vertical circles extended from the North Pole to the South Pole. The zero degree longitude, which passes through Greenwich, England, divides the Earth into the Eastern and Western hemispheres. The 180 degree longitude, half way around the planet, is the international date line.

LONGITUDE

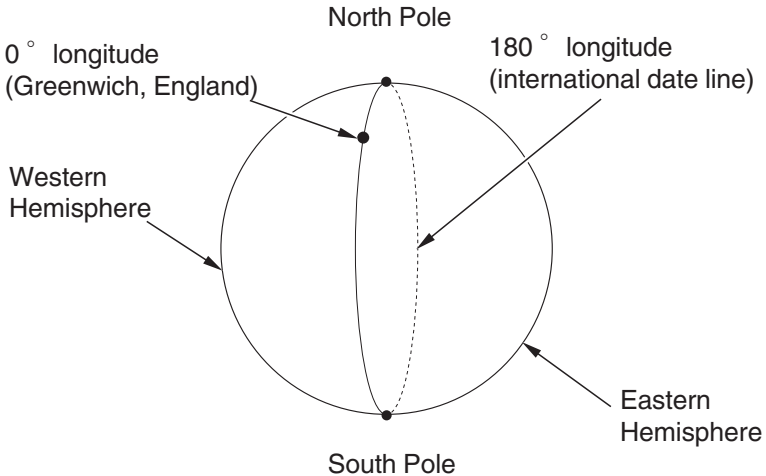

Each longitude 69 miles wide
Each time zone equals 15° longitude

Introduction

Your ATV GPScape System receives signals from the Global Positioning System (GPS), a U.S. government network that orbits the Earth, then uses those signals to calculate your current position as well as the distance and direction to other locations (destinations).

In addition to latitude and longitude, GPScape also calculates altitude (above sea level).

The primary uses of your GPScape System are:

- making your current location for future use as a waypoint (navigating position)
- inputting the latitude and longitude of a destination as a waypoint
- using the system to guide you to a waypoint

We're sure you'll enjoy using your GPScape System. It is an excellent navigation aid, but successful navigation also requires your careful attention to the terrain you are riding and your good judgment.

Important Safety Information

The GPScope System is designed to provide information to help you reach selected destinations. While this system provides the direction and distance to a destination, it does not provide an actual path. You must use your own observation of the terrain and good judgment in choosing a safe path to reach the destination.

Also, be aware that the system can distract your attention from operating your ATV if you focus too much on the display or operate the system's controls while riding. Do not look at the display unless you decide you can do so safely.

WARNING

Using the GPScope System while you are riding can take your attention away from the terrain, causing a crash in which you could be seriously injured or killed.

- Do not look at the display for more than a second or so at a time while riding.
- Stop your ATV if you need more time to look at the display or operate the system controls.

System Limitations

Your GPScape System uses signals from the Global Positioning System operated by the U.S. Department of Defense. For security reasons, certain inaccuracies are built into GPS that your navigation system must constantly compensate for. This can cause occasional positioning errors of up to several hundred feet.

Since GPScape receives information from satellites orbiting the Earth, your system's receiver requires a relatively unobstructed view of the sky. Obstructions that will limit your system's sky view include (but are not limited to) buildings, canopies, heavy rain or snow, or tree foliage.

System Start-up

Position Fix

The GPScope System uses satellite information to compute your present position (called a position fix).

Depending on the elapsed time since the ignition was last switched OFF (\circ), there are three approximate response times for the system to acquire your position fix.

Time Elapsed Since Ignition Switched OFF	Approximate Time for System to Acquire Position Fix After Turning Ignition ON
less than 2 hours	25 seconds
more than 2 hours, less than a month	2 minutes
more than a month	8 minutes

If your ATV is transported with the ignition switch OFF (\circ) for over 60 miles (100 km) or if your ATV is not started for at least three months, we recommend that you reset your system by following the procedure on the following page, *System Failure to Display a Position Fix*.

System Start-up

System Failure to Display a Position Fix

If the receiver does not get a position fix within about 8 minutes (flashing antenna mark (1) as shown in the illustration), make sure there are no overhead obstructions (building, trees, canopy, etc.) and then perform the following:

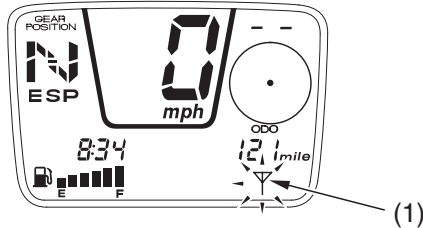

(1) antenna mark

1. Turn the ignition switch OFF (O).
2. Remove the battery cover (2) by removing the bolts (3).
3. Disconnect the negative (-) terminal lead (4) from the battery (5) and wait for 1 minute.

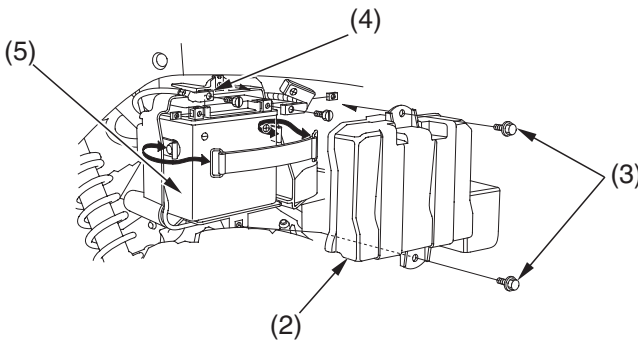

(2) battery cover
(3) bolts



(4) negative (-) terminal lead
(5) battery

System Start-up

4. Reconnect the negative (–) terminal lead and install in the reverse order of removal.
 - If you can not obtain a position fix after performing this procedure, see your Honda dealer.

Satellite Status

The satellite status indicates the amount of information received from GPS satellites in one of three possible categories:

Display	Status	
	Not Usable	The system is signaling (flashing antenna mark) that your position fix is not available.
	2D Navigation	The system has determined latitude and longitude, but is unable to determine altitude. 2D Navigation is not as accurate as 3D Navigation.
	3D Navigation	The system has determined latitude, longitude, and altitude. The receiver is ready to provide navigational information.

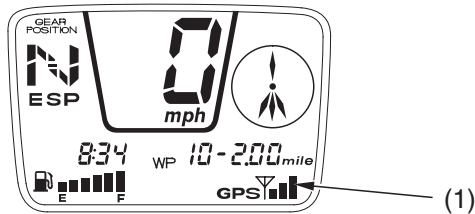

(1) satellite status (signal strength indicator)

- If there are large obstacles nearby or overhead, move to a new location with a clear view of the sky.

Satellite Status

If the GPS mark (2) blinks as shown in the illustration.
See your Honda dealer to check and restore the GPSScape System.

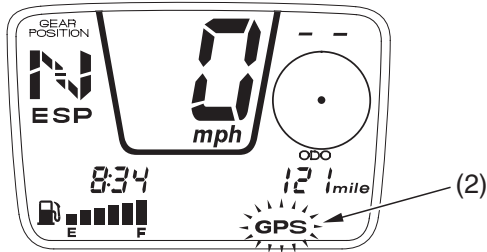

(2) GPS mark

GPS Mode

A waypoint is a geographical position (location) on the surface of the Earth. GPScape allows you to log up to 100 positions as navigational waypoints. You may then use GPScape to show you the direction of any selected waypoint, and how far you are from that waypoint via straight-line travel.

You may mark such waypoints as home, base camp, your favorite riding, fishing, or hunting spots, as well as locations of wildlife sightings. Because you have 100 waypoints available, you may mark several intersections or landmarks as waypoints during a trail ride.

GPS Mode

The GPS mode (1) shows the shortest distance to your selected waypoint. And, when your ATV is moving (one mph or faster), the GPS mode also displays an electronic arrow to indicate the direction to the selected waypoint.

Push the GPS/WP button (2) to switch between the GPS mode and the other two modes: odometer and tripmeter.

To change the display to odometer or tripmeter, press and release the odometer/tripmeter select button (3) while the display is in the GPS mode. The display will change to the previous display mode (odometer or tripmeter).

Any time you are not in the GPS mode, the compass direction indicator (4) will function while your ATV is moving (one mph or faster) (page 70).

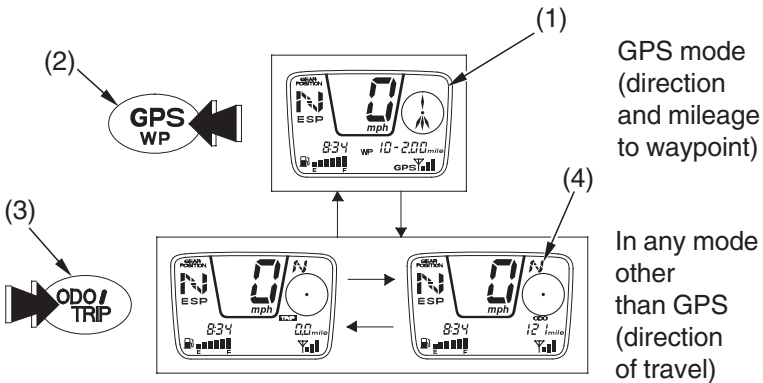

- (1) GPS mode
- (2) GPS/WP button
- (3) odometer/tripmeter select button
- (4) compass direction indicator

GPS Mode

GPS Mode Display

The GPS mode display (1) includes the following functions:

GPS Function	Digital Readout
waypoint number (2)	0 – 99
distance to waypoint (3)	“- - -” (3 digits for miles, and if applicable, tenths and hundredths, with a floating decimal)
direction to waypoint (4)	

The GPS mark (5) appears in the display while the GPS mode is selected. The signal strength indicator (6) appears as long as the GPS signal is active.

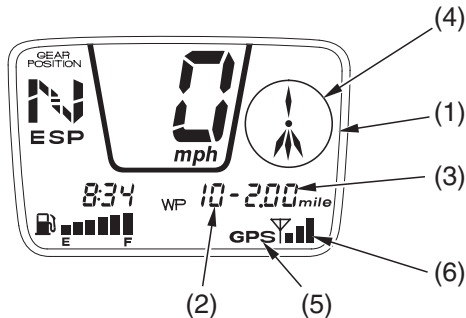

- (1) GPS mode display
- (2) waypoint number
- (3) distance to waypoint
- (4) direction to waypoint
- (5) GPS mark
- (6) signal strength indicator

GPS Mode

Waypoint Number Display

A waypoint number appears in the display when the GPS mode is selected. You can store up to 100 waypoints, numbered from 0-99. To mark a waypoint, see page 63.

To select a waypoint number:

- To select a higher waypoint number, press and release the plus button (2).
- To select a lower waypoint number, press and release the minus button (3).
- To fast scroll: press and hold the plus or minus button until the desired waypoint number appears.

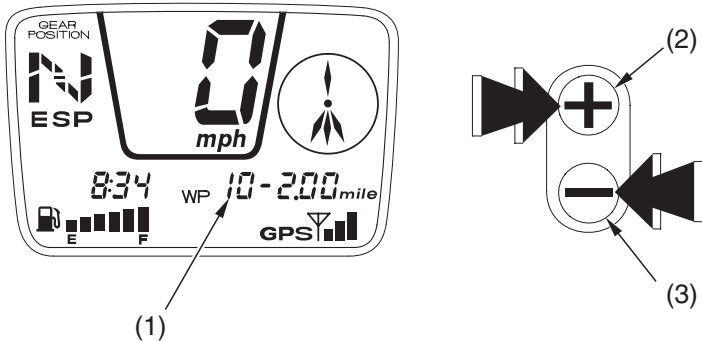

(1) waypoint number
(2) plus button

(3) minus button

GPS Mode

Direction to Waypoint Display

The direction to waypoint display (1) uses an electronic arrow to point to your destination. The display has 16 possible directions.

While operating in reverse, GPS will continue to direct you as if your ATV is still moving in a forward direction. However, the system will calculate an accurate distance and display a directional arrow to the selected waypoint.

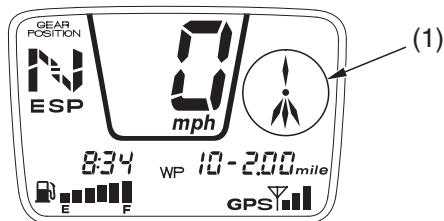

(1) direction to waypoint

When your ATV approaches within about 16 feet of the waypoint, the direction to waypoint display will change from a directional arrow to an eight-point star (2) as shown in the illustration.

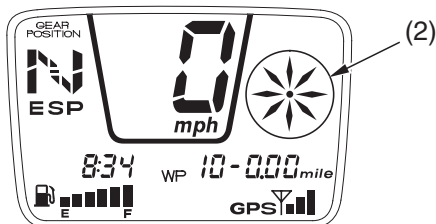

(2) eight-point star

GPS Mode

If the receiver loses a position fix (because of a large obstacle nearby or overhead), the direction to waypoint display will disappear as shown in the illustration and the antenna mark (3) will flash.

- The distance to waypoint display will continue to display the last value shown before the loss of the position fix.

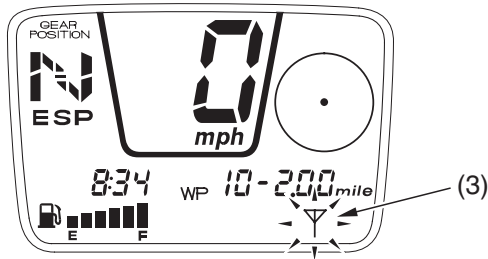

(3) antenna mark

If the receiver reacquires a position fix, the direction to waypoint display will appear as shown in the illustration.

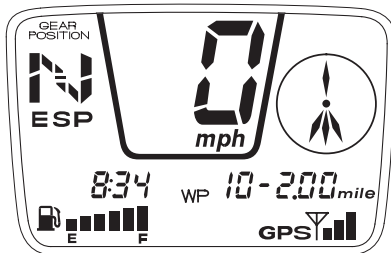

GPS Mode

Distance to Waypoint

The distance to waypoint (1) display shows the straight line distance from your present location to the waypoint.

The distance range display shows three numerals with a “floating” decimal:

Range	Display
Less than 10 miles	0.01 – 9.99
10 miles up to 1,000 miles	10 – 999

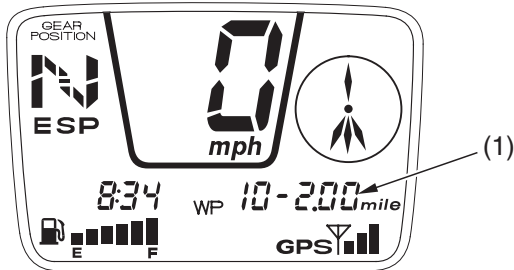

(1) distance to waypoint

GPS Mode

There are two methods for marking waypoints.

- Basic (to select your current position)
- Advanced (to input desired destinations)

Basic Waypoint Selection

To Mark Your Present Position:

1. Turn the ignition switch ON (1).
2. Use the GPS/WP button (1) to select the GPS mode.
3. To select a higher waypoint number (2), press and release the plus button (3).
To select a lower waypoint number, press and release the minus button (4).
- To fast scroll, press and hold the plus or minus button until the desired waypoint number appears.
4. Press and hold the GPS/WP button (1) for about 2 seconds, until the waypoint number and distance to waypoint (5) flash. Then release the button.

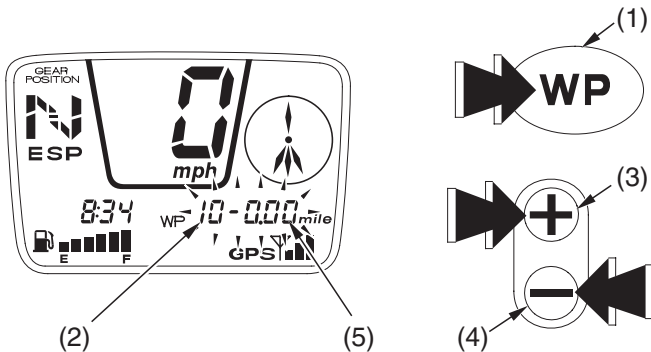

- | | |
|---------------------|--------------------------|
| (1) GPS/WP button | (4) minus button |
| (2) waypoint number | (5) distance to waypoint |
| (3) plus button | |

(cont'd)

GPS Mode

5. Within 5 seconds, to mark your present position, tap (do not hold) the GPS/WP button. (The waypoint will not be set unless the GPS/WP button is pressed a second time. Do not hold the GPS/WP button down. This will cause the system to transition to the advanced waypoint entry procedure.)

The direction to waypoint display (6) will light as shown in the illustration.

- In the 2D Navigation status, the calculated waypoint location may not be as accurate as 3D Navigation.

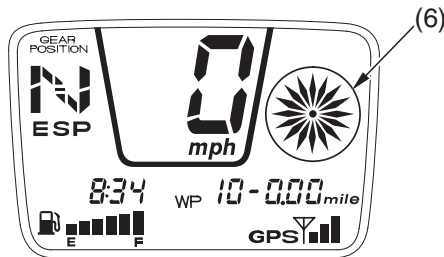

(6) direction to waypoint display

As soon as you start moving (one mph or faster), the direction to waypoint arrow will appear, pointing toward the selected waypoint location.

GPS Mode

Advanced Waypoint Selection

Advanced Latitude & Longitude Entry Sequence

latitude	1	--° (degrees)	longitude	1	---° (degrees)
	2	--' (minutes)		2	--' (minutes)
	3	-- (seconds)		3	-- (seconds)
	4	.-" (tenths of second)		4	.-" (tenths of second)

To input a waypoint value using latitude and longitude coordinates:

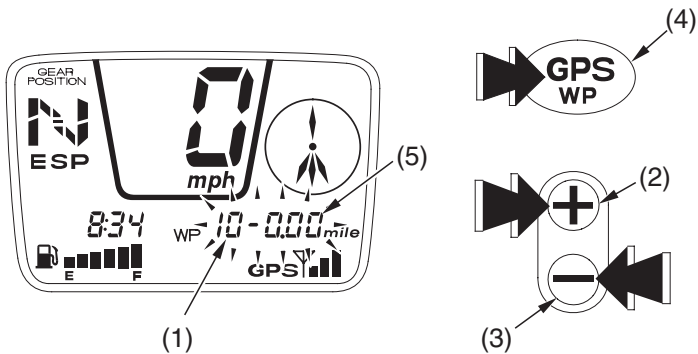

- (1) GPS/WP button
- (2) waypoint number
- (3) plus button
- (4) minus button
- (5) distance to waypoint

(cont'd)

GPS Mode

1. Turn the ignition switch ON (1).
2. Use the GPS/WP button (1) to select the GPS mode.
3. To select a higher waypoint number (2), press and release the plus button (3).
To select a lower waypoint number, press and release the minus button (4).
To fast scroll, press and hold the plus or minus button until the desired waypoint number appears.
4. Press and hold the GPS/WP button for about 2 seconds, until the waypoint number and distance to waypoint (5) flash. Then release the button.
5. While the display is still blinking, press and hold the GPS/WP button again for about 2 seconds until LAT appears above the WP mark. The compass direction indicator will flash Northern Latitude (6) or Southern Latitude (7), indicating the hemisphere. (To switch to the other hemisphere, press either the plus or minus button.)
6. Tap (do not hold) the GPS/WP button. The degree (8) will begin flashing.

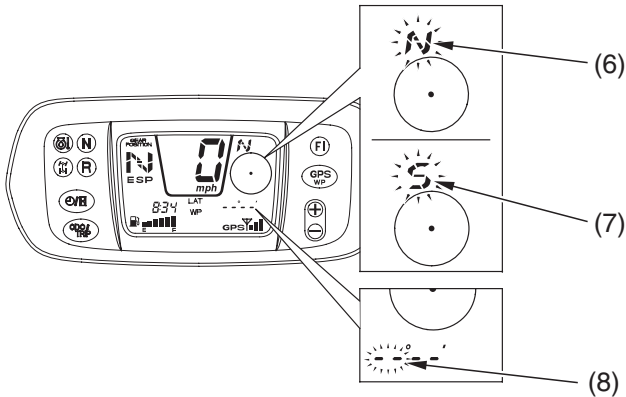

(6) Northern Latitude
(7) Southern Latitude

(8) degree

GPS Mode

7. To select your entry:

- To increase, tap the plus button.
- To decrease, tap the minus button.
- To fast change in units of 10, press and hold the plus button (to increase) or the minus button (to decrease) until the desired entry appears.

8. To enter the displayed value into the system, tap (do not hold) the GPS/WP button. The next level in the entry sequence will begin flashing.

9. To select and enter the minutes (9) – follow the same procedure used in steps 7 – 8.

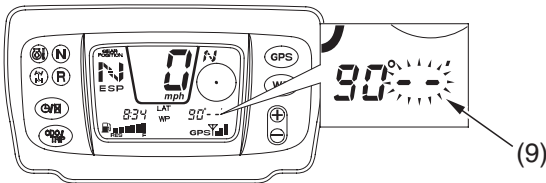

(9) minute

10. To select and enter the seconds (10) – follow the same procedure used in steps 7 – 8.

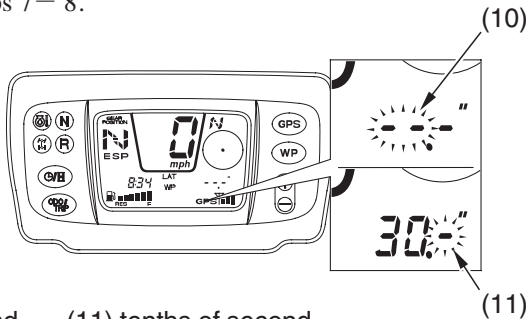

(10) second

(11) tenths of second

(cont'd)

GPS Mode

11. To select the tenths of a second (11):
 - To increase, tap the plus button.
 - To decrease, tap the minus button.
12. To enter the displayed tenths of a second in the system, tap (do not hold) the GPS/WP button until LON appears above the WP mark. The compass direction indicator will flash Eastern Longitude (12) or Western Longitude (13).
(To switch to the other hemisphere, press either the plus or minus button.)

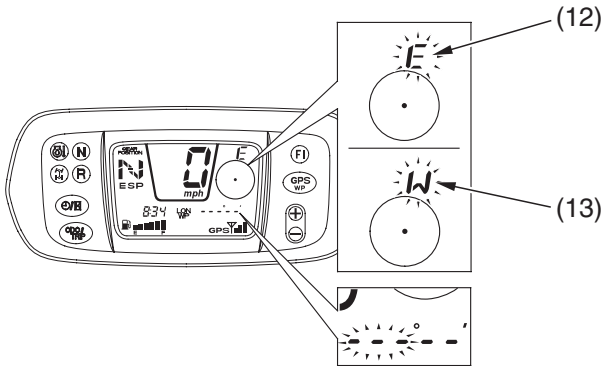

- (12) Eastern Longitude
(13) Western Longitude

13. To enter the longitude coordinates, follow the same procedure used in steps 6 – 11 .

To Correct Input:

Push the GPS/WP button (1). This reverses the sequence so you can back up and make a correction.

Once the 1/10 second longitude entry is completed, you can no longer back up in the sequence to make a correction.

To Change the Coordinates for an Existing Waypoint Number:

Follow steps 1 – 4 under *Advance Waypoint Selection* (page 65) and “overwrite” your previous waypoint.

Determining the Coordinates of Your Current Position

1. If your current position is not already marked, mark it (page 63).
2. Press and hold the GPS/WP button until the display begins blinking.
3. While the display is still blinking, press and hold the GPS/WP button again until the display shows LAT degrees and minutes.
4. Tap (do not hold) the GPS/WP button repeatedly to sequence through the coordinates display.
5. Tap the GPS/WP button again to return to the distance to waypoint display.

Compass Direction Indicator

The compass direction indicator does not appear when the system is in the GPS mode. Instead, you will see the direction to waypoint arrow — as long as your ATV is moving (one mph or faster).

The compass direction indicator (1) shows the heading of your ATV when the system is in the odometer or tripmeter mode — as long as your ATV is moving (one mph or faster). Your ATV must be moving to allow GPScape to calculate your present direction compared to your previous location.

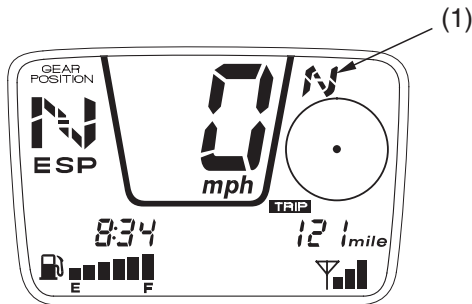

(1) compass direction indicator

The compass direction indicator displays 8 possible directions:

N	North	NW	Northwest
S	South	NE	Northeast
E	East	SW	Southwest
W	West	SE	Southeast

Compass Direction Indicator

If the receiver loses a position fix (because of a large obstacle nearby or overhead), the compass direction indicator will disappear as shown in the illustration and the antenna mark (2) will flash.

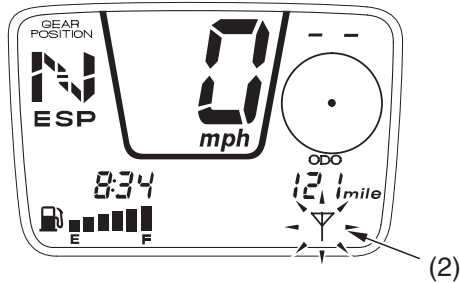

(2) antenna mark

If the receiver reacquires a position fix, the compass direction indicator will appear as shown in the illustration.

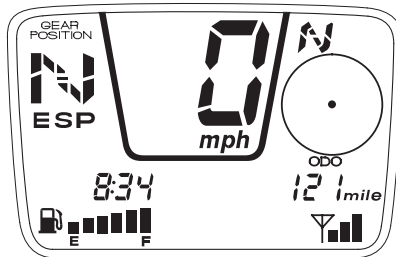

Automatic Clock Adjustment

Your ATV digital clock has an automatic adjustment function when the system's satellite status is 3D Navigation (page 54).

The system will adjust the digital clock display after receiving the basic UT (universal time, formerly referred to as Greenwich Mean Time) and then calculating your local time.

The automatic digital clock adjustment will start to function about one minute after your ATV's battery is connected and the initial manual clock adjustment is completed.

The automatic time adjustment should be accurate within plus-or-minus 5 minutes. To switch between standard and daylight saving time, adjust the clock manually (page 26).

Before Riding

Before each ride, you need to make sure you and your Honda are both ready to ride. To help get you prepared, this section discusses how to evaluate your riding readiness, what items you should check on your ATV, and adjustments to make for your comfort, convenience, or safety. This section also includes important information about loading.

Are You Ready to Ride ?	74
Protective Apparel.....	74
Rider Training	76
Age Recommendation.....	77
No Passengers	77
No Alcohol or Drugs.....	78
Is Your ATV Ready to Ride ?.....	79
Pre-ride Inspection	79
Load Limits & Guidelines.....	83
Loading	83
Cargo and Trailer Information	84
Loading Guidelines	86
Accessories & Modifications	87
Accessories.....	87
Modifications	88

Are You Ready to Ride?

Before you ride your ATV for the first time, we urge you to:

- Read this owner's manual and the labels on your ATV carefully.
- Make sure you understand all the safety messages.
- Know how to operate all the controls.

Before each ride, be sure:

- You feel well and are in good physical and mental condition.
- You are wearing an approved motorcycle helmet (with chin strap tightened securely), eye protection, and other protective clothing.
- You don't have any alcohol or drugs in your system.

Protective Apparel

For your safety, we strongly recommend that you always wear an approved motorcycle helmet, eye protection, boots, gloves, long pants, and a long-sleeved shirt or jacket whenever you ride.

Although complete protection is not possible, wearing proper gear can reduce the chance of injury when you ride.

Following are suggestions to help you choose the proper gear.

Helmets and Eye Protection

Your helmet is your most important piece of riding gear because it offers the best protection against head injuries. A helmet should fit your head comfortably and securely.

Are You Ready to Ride?

An open-face helmet offers some protection, but a full-face helmet offers more. Regardless of the style, look for a DOT (Department of Transportation) sticker in any helmet you buy (USA only). Always wear a face shield or goggles to protect your eyes and help your vision.

WARNING

Operating this ATV without wearing an approved motorcycle helmet, eye protection, and protective clothing could increase your chances of severe injury or death in the event of an accident.

Always wear an approved motorcycle helmet that fits properly and wear eye protection (goggles or face shield), gloves, boots, long-sleeved shirt or jacket and long pants.

Additional Riding Gear

In addition to a helmet and eye protection, we also recommend:

- Sturdy off-road motorcycle boots to help protect your feet, ankles, and lower legs.
- Off-road motorcycle gloves to help protect your hands.
- Riding pants with knee and hip pads, a riding jersey with padded elbows, and a chest/shoulder protector.

Are You Ready to Ride?

Rider Training

Developing your riding skills is an on-going process. Even if you have ridden other ATVs, take time to become familiar with how this ATV works and handles. Practice riding the ATV in a safe area to build your skills. Do not ride in rough terrain until you get accustomed to the ATV's controls, and feel comfortable with its size and weight.

We urge all riders to take a certified course approved by the ATV Safety Institute (ASI). For information about the ASI training course nearest you, call the national toll-free number; (800) 887-2887 (USA only).

Other riding tips can be found in the *Tips & Practice Guide for the ATV Rider* booklet that came with your ATV (USA only).

WARNING

Operating this ATV without proper instruction could increase your risk of an accident which could lead to serious injury or death.

Beginning and inexperienced operators should complete the certified training course offered by Honda. They should then regularly practice the skills learned in the course and the operating techniques described in the owner's manual.

Are You Ready to Ride?

Age Recommendation

The minimum recommended age for this ATV model is 16. For safety, never let children under 16 years old operate this vehicle.

WARNING

A child using an ATV that is not recommended for their age could lose vehicle control while riding, resulting in severe injury or death.

A child under 16 should never operate an ATV with engine size greater than 90cc.

No Passengers

This ATV is designed as an operator-only vehicle. The long seat is designed to allow the rider to change body position, not for carrying a passenger. Never let a passenger ride on the seat or on the front or rear cargo racks.

WARNING

Carrying a passenger on this ATV greatly reduces your ability to balance and control this ATV and could cause a crash and you or your passenger could be injured or killed.

Never carry a passenger on this ATV.

Are You Ready to Ride?

No Alcohol or Drugs

Alcohol, drugs and ATVs don't mix. Even a small amount of alcohol can impair your ability to operate an ATV safely. Likewise, drugs — even if prescribed by a physician — can be dangerous while operating an ATV. Consult your doctor to be sure it is safe to operate a vehicle after taking medication.

WARNING

Operating this ATV after consuming alcohol or drugs can seriously affect your judgement, cause you to react more slowly, affect your balance and perception, and result in serious injury or death.

Never consume alcohol or drugs before or while operating this ATV.

Is Your ATV Ready to Ride?

Before each ride, it's important to inspect your ATV and make sure any problem you find is corrected. A pre-ride inspection is a must, not only for safety, but because having a breakdown, or even a flat tire, can be a major inconvenience.

If your ATV has overturned or been involved in a collision, do not ride the vehicle until it has been inspected by your Honda dealer. There may be damage or other problems you cannot see.

WARNING

Improperly maintaining this ATV or failing to correct a problem before riding can cause a crash in which you can be seriously hurt or killed.

Always perform a pre-ride inspection before every ride and correct any problems.

Pre-ride Inspection

Check the following items before you get on the ATV:

<i>Engine Oil</i>	Check the level and add oil if needed (page 147). Check for leaks.
<i>Radiator Coolant</i>	Check the coolant level and add coolant if needed (page 157). Check for leaks.

(cont'd)

Is Your ATV Ready to Ride?

<i>Fuel</i>	Check the level and add fuel (page 142) if needed. Also make sure the fuel fill cap is securely fastened. Check for leaks.
<i>Tires</i>	Use a gauge to check the air pressure. Adjust if needed. Also look for signs of damage or excessive wear (page 185).
<i>Driveshaft Boots</i>	Check for damage (page 190).
<i>Nuts & Bolts</i>	Check the wheels to see that the axle nuts are tightened. Use a wrench to make sure all accessible nuts, bolts, and fasteners are tight.
<i>Underbody & Exhaust System</i>	Check for, and remove, any dirt, vegetation or other debris that could be a fire hazard or interfere with the proper operation of the vehicle.
<i>Air Cleaner Housing Drain Tube</i>	Check for deposits in the drain tube. If necessary, clean the tube (page 165) and check the air cleaner housing.
<i>Leaks, Loose Parts</i>	Walk around your ATV and look for anything that appears unusual, such as a leak or loose cable.
<i>Cable</i>	Check the cable housings for wear. Check the fittings for looseness. Replace or tighten as needed.
<i>Lights</i>	Make sure the headlight, brakelight and taillight are working properly.

Is Your ATV Ready to Ride?

If you are carrying cargo, also check the following:

Loading Limits Make sure you do not exceed the load limits (page 83).

Cargo Check that all cargo is secure.

Check these items after you get on the ATV:

Throttle Check the freeplay and adjust if needed. Press the throttle to make sure it moves smoothly without sticking, and snaps shut automatically when it is released, in all steering positions (page 166).

Brakes Squeeze the front and rear brake levers and step on the rear brake pedal to check that the controls operate normally. Depress the rear brake pedal several times, then check for proper brake lever freeplay (page 179). Make sure there is no brake fluid leakage.

(cont'd)

Is Your ATV Ready to Ride?

*Headlight and
Headlight Dimmer
Switch*

Check for proper function (page 35).

*Engine Stop
Switch*

Check for proper function (page 34).

Steering

Check that the wheels turn properly as you steer the handlebar. Move the handlebar right and left and check that there is no excessive backlash.

Remember, be sure to take care of any problem you find, or have your Honda dealer correct it before you ride.

Load Limits & Guidelines

Your Honda was designed as a rider-only ATV. It was not designed to carry a passenger. It can carry cargo on the cargo racks, however, carrying cargo anywhere else or carrying a passenger could interfere with your balance and control of the ATV.

In addition, exceeding the weight limits or carrying an unbalanced load can seriously affect your ATV's handling, braking and stability. Adding accessories or making modifications that change this ATV's design and performance can also make it unsafe. Also, the weight of any accessories will reduce the maximum load the ATV can carry.

More specific information on load limits, accessories, and modifications follows.

Loading

How much weight you put on your ATV, and how you load it, are important to your safety. If you decide to carry cargo, you should be aware of the following information.

WARNING

Overloading, improper loading, or carrying a passenger can cause a crash and you can be seriously hurt or killed.

Follow all load limits and other loading guidelines in this manual.

Load Limits & Guidelines

Cargo and Trailer Information

The ATV was designed to carry you and a specific amount of cargo. The ATV can be used to tow a trailer and a specific amount of cargo with the installation of Honda Trailer Hitch.

The Hondaline Trailer Hitch Kit contains specific information regarding trailer towing with the ATV. Towing a trailer without reading this information is not recommended.

Cargo and/or the addition of a trailer will affect the acceleration, braking and handling of the ATV. Do not exceed the recommended limits listed below. Follow the guidelines (page 85).

The following load limits apply to standard equipment only. Modifying your ATV, using non-standard equipment, or riding on terrain that is not flat and smooth could further reduce these limits.

Load Limits & Guidelines

Following are the load limits for your ATV:

maximum weight capacity 485 lbs (220 kg)
(includes the weight of the rider, all cargo, and accessories.)

front cargo rack weight limit = 66 lbs (30 kg)

rear cargo rack weight limit = 133 lbs (60 kg)

tow weight limit = 850 lbs {385 kgf}

(Combined weight of the trailer
and all cargo in the trailer) (3776 N)

tongue weight = 30 lbs {14 kgf}

(Weight on the trailer tongue) (137 N) recommended

tongue and rear cargo weight = 133 lbs (60 kg) maximum

(Combined weight on the trailer
tongue and on the rear cargo rack)

Tongue weight can be measured with an ordinary bathroom scale. Place the scale under the tongue, using either a tongue jack or other support to keep the trailer level.

The weight of added accessories will reduce the maximum cargo weight you can carry.

Load Limits & Guidelines

Loading Guidelines

Carrying cargo or pulling a trailer will affect how your ATV handles and greatly reduce its ability in accelerating, braking and making turns and other maneuvers.

Be sure to observe the weight limits and follow these guidelines:

- Check that the tires are properly inflated.
- Do not place cargo anywhere on the ATV other than on the front and rear racks. Otherwise, operating stability may be adversely affected.
- Never ride with a passenger on the front or rear cargo racks. The ATV is not designed to carry a passenger.
- Use the trailer hitch to tow another vehicle or trailer. Do not tow by tying a rope or cable to the rear rack.
- Load cargo on the rear rack as far forward as possible. Make sure cargo on the front rack does not interfere with handlebar movement.
- Do not allow cargo to extend beyond the edges of either the front or rear racks.
- Make sure all cargo is secured before riding.
- Balance cargo weight evenly on both sides.
- Never exceed the maximum weight limit.
- When towing a trailer, take care to maintain balance and stability. Distribute cargo between the front and rear of the trailer to obtain the recommended tongue weight.
- When towing a trailer, select the ESP mode (page 102), and choose the 1st shift position.
- Allow extra room for starting, stopping and turning whenever you carry cargo or pull a trailer.
- Avoid riding on steep slopes when carrying cargo or pulling a trailer.
- Never cross a slope when towing a trailer.

Accessories & Modifications

Modifying your ATV or using non-Honda accessories can make your ATV unsafe.

Before you consider making any modifications or adding an accessory, be sure to read the following information.

WARNING

Improper accessories or modifications can cause a crash in which you can be seriously hurt or killed.

Follow all instructions in this owner's manual regarding accessories and modifications.

Accessories

We strongly recommend that you use only genuine Honda accessories that have been specifically designed and tested for your ATV. Because Honda cannot test all other accessories, you must be personally responsible for proper selection, installation, and use of non-Honda accessories.

Check with your Honda dealer for assistance and always follow these guidelines:

- Make sure the accessory does not obscure any lights, reduce ground clearance, limit suspension travel or steering travel, or interfere with operating any controls.
- Make sure the accessory does not interfere with your ability to shift body position on the seat or operate hand and foot controls.
- Do not add any electrical equipment that will exceed the vehicle's electrical system capacity (page 239). A blown fuse can cause a loss of lights or engine power (page 224).

Accessories & Modifications

Modifications

We strongly advise you not to remove any original equipment or modify your ATV in any way that would change its design or operation. Such changes could seriously impair your ATV's handling, stability, and braking, making it unsafe to ride.

We also advise you not to make any modifications or remove any equipment (such as the USDA qualified spark arrester or emission control system components) that would make your ATV illegal in your area.

Removing or modifying your lights, exhaust system, emission control system, or other equipment can also make your ATV illegal.

Basic Operation & Riding

This section gives basic riding instructions, including how to start and stop your engine, and how to use the throttle and brakes. It also provides important information on riding with cargo.

To protect your new engine and enjoy optimum performance and service life, refer to Break-in Guidelines (page 240).

Safe Riding Precautions	91
Off-Road Use Only	91
Keep Hands and Feet on Controls.....	92
Control Speed.....	93
Use Care on Unfamiliar or Rough Terrain.....	94
Do Not Perform Stunts.....	95
Starting & Stopping the Engine	96
Preparation	96
Starting Procedure	97
Flooded Engine	98
Bank Angle Sensor Ignition Cut – off System.....	98
Stalled Engine	99
How to Stop the Engine	100
Using the Recoil Starter	101
Shifting Gears	102
Riding in Reverse.....	108

(cont'd)

Basic Operation & Riding

Braking.....	110
Riding Your ATV	112
Making Turns.....	112
Skidding or Sliding	114
Riding Up Hills	115
Riding Down Hills	119
Crossing or Turning on Hills or Slopes.....	120
Riding Over Obstacles	122
Riding Through Water	123
Parking	124

Safe Riding Precautions

Before riding your ATV for the first time, please review the *ATV Safety* section beginning on page 1, and the *Before Riding* section beginning on page 73 .

Even if you have ridden other ATVs, take time to become familiar with how this ATV works and handles. Practice in a safe area until you build your skills and get accustomed to the ATV's size and weight.

Off-Road Use Only

Your ATV and its tires are designed and manufactured for off-road use only, not for pavement. Riding on pavement can affect handling and control. You should not ride your ATV on pavement.

WARNING

Operating this ATV on paved surfaces may seriously affect handling and control of the ATV, and may cause the vehicle to go out of control.

Never operate the ATV on any paved surfaces, including sidewalks, driveways, parking lots and streets.

When riding off-road, also remember to always obey local off-road riding laws and regulations. Obtain permission to ride on private property. Avoid posted areas and obey “no trespassing” signs.

(cont'd)

Safe Riding Precautions

You should never ride your ATV on public streets, roads or highways, even if they are not paved. Drivers of street vehicles may have difficulty seeing and avoiding you, which could lead to a collision. In many states it is illegal to operate ATVs on public streets, roads and highways.

WARNING

Operating this ATV on public streets, roads or highways could cause you to collide with another vehicle.

Never operate this ATV on any public street, road or highway, even a dirt or gravel one.

Keep Hands and Feet on Controls

Always keep both hands on the handlebars and both feet on the footpegs when riding your ATV. This is important to maintain your balance and to control the vehicle. Removing even one hand from the handlebars or one foot from the footpegs can reduce your ability to control the ATV or could cause you to lose your balance and fall off the ATV.

WARNING

Removing hands from handlebars or feet from footpegs during operation can reduce your ability to control the ATV or could cause you to lose your balance and fall off of the ATV.

Always keep both hands on the handlebars and both feet on the footpegs of your ATV during operation.

Safe Riding Precautions

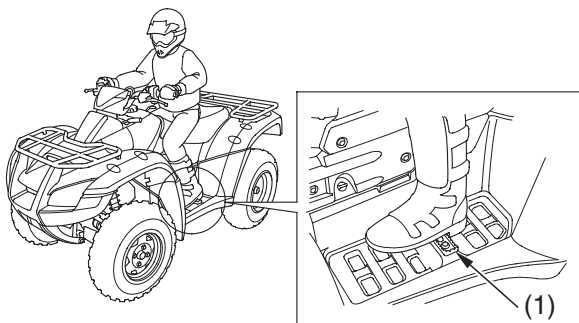

(1) footpeg

Control Speed

Riding at excessive speed increases the chance of an accident. In choosing a proper speed, you need to consider the capability of your vehicle, the terrain, visibility and other operating conditions, plus your own skills and experience.

⚠ WARNING

Operating this ATV at excessive speeds increases your chances of losing control of the ATV, which can result in an accident.

Always go at a speed that is proper for your vehicle, the terrain, visibility and other operating conditions, and your experience.

Safe Riding Precautions

Use Care on Unfamiliar or Rough Terrain

Before riding in a new area, always check the terrain thoroughly. Don't ride fast on unfamiliar terrain or when visibility is limited. (It's sometimes difficult to see obstructions like hidden rocks, bumps, or holes in time to react.)

WARNING

Failure to use extra care when operating this ATV on unfamiliar terrain could result in the ATV overturning or going out of control.

Go slowly and be extra careful when operating on unfamiliar terrain. Always be alert to changing terrain conditions when operating the ATV.

Safe Riding Precautions

Never ride past the limit of visibility. Maintain a safe distance between your ATV and other off-road vehicles. Always exercise caution, and use extra care on rough, slippery and loose terrain.

WARNING

Failure to use extra care when operating on excessively rough, slippery or loose terrain could cause loss of traction or vehicle control, which could result in an accident, including an overturn.

Do not operate on excessively rough, slippery or loose terrain until you have learned and practiced the skills necessary to control the ATV on such terrain. Always be especially cautious on these kinds of terrain.

Do Not Perform Stunts

You should always operate your ATV in a safe and reasonable manner. When riding, always keep all four wheels on the ground.

WARNING

Attempting wheelies, jumps, and other stunts increases the chance of an accident, including an overturn.

Never attempt stunts, such as wheelies or jumps. Don't try to show off.

Starting & Stopping the Engine

Always follow the proper starting procedure described below.

For your safety, avoid starting or operating the engine in an enclosed area such as a garage. Your ATV's exhaust contains poisonous carbon monoxide gas which can collect rapidly in an enclosed area and cause illness or death.

Preparation

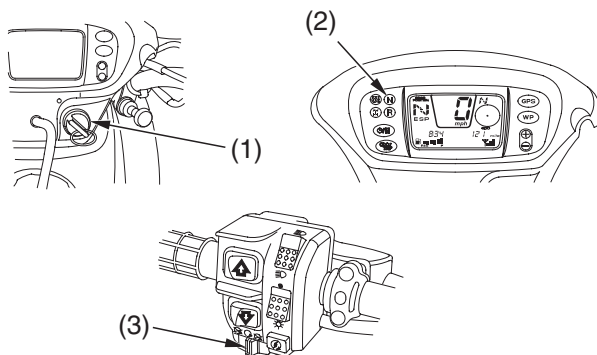

(1) ignition switch

(3) engine stop switch

(2) neutral indicator

1. Before starting, select a level surface and lock the parking brake (page 40).
2. Turn the ignition switch (1) ON (|).

Confirm the following:

- The transmission is in neutral (neutral indicator (2) ON).
- The engine stop switch (3) is set to RUN (◯).

Starting & Stopping the Engine

Starting Procedure

This vehicle has a fuel-injected with an automatic choke.
Follow the procedure indicated below.

Any Air Temperature

- Press the start button with the throttle completely closed.

The engine will not start if the throttle is fully open (Because the electronic control module cuts off the fuel supply).

Starting & Stopping the Engine

Flooded Engine

If the engine fails to start after repeated attempts, it may be flooded with excess fuel. To clear a flooded engine:

1. Leave the engine stop switch set to RUN (\odot).
2. Open the throttle fully.
3. Press the start button for 5 seconds (or operate the recoil starter several times).
4. Follow the normal starting procedure.
5. If the engine starts, then open the throttle slightly if idling is unstable. If the engine does not start, wait 10 seconds, then follow steps 1 – 4 again.

If the engine still won't start, refer to *If Your Engine Quits or Won't Start*, page 220 .

Bank Angle Sensor Ignition Cut-off System

Your vehicle's banking (lean angle) sensor system is designed to automatically stop the engine if the vehicle is overturned.

Before restarting the engine, you must turn the ignition switch to the OFF position and then back to ON. The engine will not restart until you perform this procedure.

Starting & Stopping the Engine

Stalled Engine

If the engine stalls, shift into neutral (N) and restart the engine.

If you are unable to shift to neutral (N) from drive (D), you can restart the engine by squeezing the front brake lever and pressing the start button while the vehicle is stopped.

Do not press the throttle lever while starting in gear. Your ATV is equipped with a start inhibitor system that will cut off the ignition if the throttle is open while attempting to start in gear.

Once you have started the engine, release the front brake lever, then apply throttle gradually.

Starting & Stopping the Engine

How to Stop the Engine

Normal Engine Stop

To stop the engine, make sure the transmission is in neutral by checking that the neutral indicator lights, and turn the ignition switch OFF (O).

The engine stop switch should normally remain in the RUN (O) position even when the engine is OFF.

If your ATV is stopped with the engine stop switch OFF (⌘) and the ignition switch ON (I), the battery will discharge.

Emergency Engine Stop

To stop the engine in an emergency, use the engine stop switch. To operate, move the switch to either OFF (⌘) position.

Starting & Stopping the Engine

Using the Recoil Starter

The recoil starter is used to start the engine when the battery is low.

To operate the recoil starter:

1. Check that the transmission is in neutral.
2. Unsnap and remove the right side cover (1).
3. Grasp the starter grip (2) firmly, then pull it out slowly approximately 4 in (100 mm).
4. Pull the grip up briskly and fully.
5. After the engine starts, allow the starter grip to return slowly.

If the starter grip does not return smoothly (because of dirt in the assembly), see your Honda dealer.

RIGHT SIDE

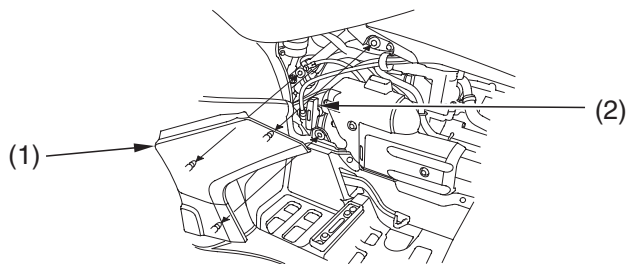

(1) right side cover

(2) recoil starter grip

The engine cannot be started if the battery is disconnected, low or dead. If the engine cannot be started with connecting the battery, charge the battery (page 195).

When the engine cannot be started even if the battery is charged, see your Honda dealer.

Shifting Gears

Your ATV has three shift lever positions: neutral (N), drive (D), and reverse (R).

Neutral (N)

Use neutral when you start the engine, or if it is necessary to stop briefly with the engine idling.

Drive (D)

Use this position for normal riding. The following two modes can be selected in the drive (D) position; automatic shift (AUTO) mode and manual shift (ESP) mode.

You can select the desired mode with the drive mode select switch (page 30).

Automatic shift (AUTO) mode:

Use this mode for everyday riding. The transmission automatically adjusts to keep the engine at the best speed for riding conditions.

The gear position indicator shows “D” and the drive mode indicator disappears.

Manual shift (ESP) mode:

In this mode, you can shift gears much like a manual transmission, but without operating a clutch.

You can select three forward shift positions by operating the shift switches; 1, 2, and 3.

The gear position indicator shows the selected position and the drive mode indicator shows “ESP.”

When you tow a trailer, select the 1st shift position for proper performance.

Reverse (R)

Use this position to ride in reverse (page 108).

Shifting Gears

The shift lever (1) is located on the left side of the fuel tank.
To shift the shift lever, bring the ATV to a complete stop.

NOTICE

If the shift lever is moved while the vehicle is moving, the transmission may be damaged.

The drive mode select switch (2) is located on the right handlebar switches.

To select the drive mode, operate the drive mode select switch.
With the throttle fully closed, the drive mode can be changed during running.

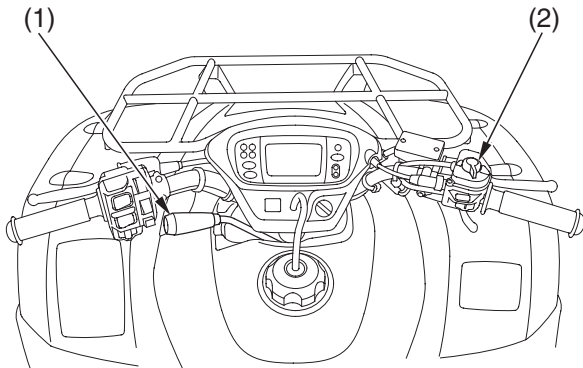

(1) shift lever

(2) drive mode select switch

Shifting Gears

AUTO Mode

When the drive mode is at AUTO, shifting the lever to “D” (drive) provides a 3-speed automatic transmission.

1. While pulling up the shift lever (1), shift to “D.”
2. Pull down the shift lever and confirm that the lever is locked and the gear position indicator (3) is showing “D.”

Shifting to “N” (neutral) or “R” (reverse) is in the same manner as above. For reverse, refer to the *Riding In Reverse* (page 108).

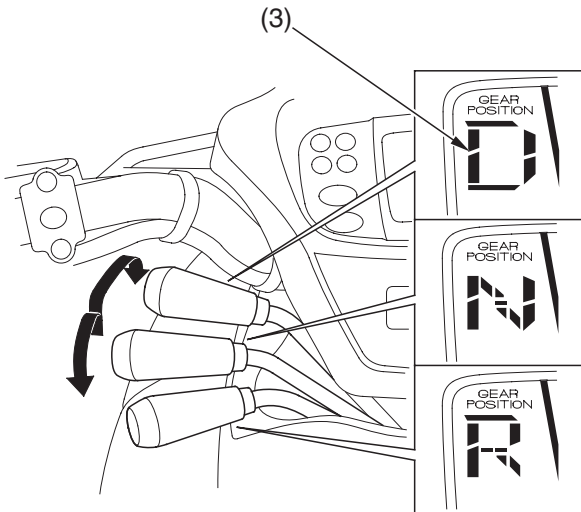

(3) gear position indicator

Shifting Gears

ESP Mode

With the drive mode set at ESP, shifting the lever to “D” allows manual shifting from 1st to 3rd using the gearshift switches.

Two gearshift switches are located next to the left handlebar grip: upshift (⬆) and downshift (⬇).

To upshift the transmission, press the upshift switch (4) once.

To downshift the transmission, press the downshift switch (5) once.

UPSHIFTING SEQUENCE

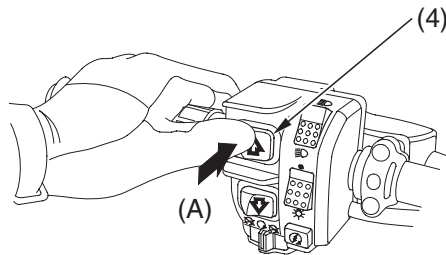

DOWNSHIFTING SEQUENCE

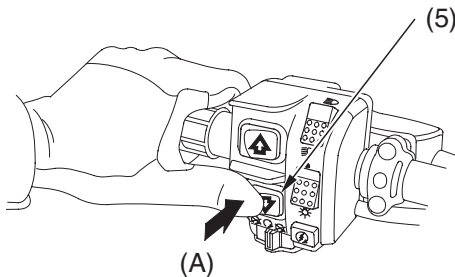

(4) upshift switch
(5) downshift switch

(A) press

Shifting Gears

After starting the engine and letting it warm up, follow these procedures:

1. Bring your ATV to a complete stop, select the ESP mode and shift the shift lever into the “D” position.

NOTICE

If the shift lever is moved while the vehicle is moving, the transmission may be damaged.

2. Release the parking brake, but continue squeezing the rear brake lever.
3. Release the rear brake lever and increase engine speed by gradually opening the throttle.
4. When speed increases, release the throttle and upshift to 2nd position by pressing the upshift switch once.
5. Repeat this sequence to progressively upshift to 3rd (top) position.
6. To downshift, press the downshift switch once. Remember to close the throttle each time you shift to the next lower position.

Learning when to shift gears in manual shift (ESP) mode comes with experience. Keep the following tips in mind:

- As a general rule, shift while moving in a straight line.
- Close the throttle completely before shifting. Improper shifting may damage the engine, transmission, and drive train.
- Upshift to a higher gear or reduce throttle before engine rpm (speed) gets too high. Learn the relationship between engine sound and the normal shifting points.
- Downshift to a lower gear before you feel the engine laboring (lugging) at low rpm.
- Avoid downshifting to help slow your ATV when engine rpm is high. Downshifting when engine speed is near its allowable maximum may over-rev the engine and cause possible damage.

Shifting Gears

- To prevent transmission damage, do not coast or tow the ATV for long distances with the engine off.

Recommended Shift Points

Ride in the highest gear that lets the engine run and accelerate smoothly. This will give you good fuel economy and effective emissions control.

Riding in Reverse

If you need to ride in reverse, make sure the area behind you is clear and only operate the ATV at low speed.

WARNING

Improperly operating in reverse could cause you to hit an obstacle or person behind you, resulting in serious injury.

Make sure there are no obstacles or people behind you before selecting reverse gear. When it is safe to proceed, go slowly.

1. Bring the vehicle to a complete stop, then make sure the transmission is in neutral.
2. Depress and hold down the brake pedal.
3. Be sure there are no obstacles or people in the way.
4. Shift the shift lever into “R” (reverse) gear.

NOTICE

If the shift lever is moved while the vehicle is moving, the transmission may be damaged.

5. Release the rear brake pedal.
6. Open the throttle gradually and ride slowly. Do not open the throttle suddenly or make abrupt turns.

Riding in Reverse

7. To stop, close the throttle and gradually apply both the front and rear brakes. Do not abruptly apply the rear brake by itself.
8. To shift out of reverse and into neutral, shift the shift lever into “N” (neutral) gear.

WARNING

Applying only the rear brake abruptly when operating in reverse gear could cause the front wheels to lift off the ground and the ATV could overturn backwards.

Carefully apply both the front and rear brakes when stopping in reverse gear.

Braking

Your ATV is equipped with disc brakes on both front wheels which are hydraulically activated by operating the right brake lever. A single disk brake of the rear drive train is hydraulically activated by depressing the brake pedal and mechanically activated by operating the left brake lever.

Although the front and rear brakes have separate controls, all four wheels are interconnected when your ATV is in the 4WD mode. So operating any brake control in the 4WD mode will cause braking at both the front and rear wheels.

As a general rule, the front braking system provides about 70 percent of total stopping power.

For full braking effectiveness, use both the pedal and lever simultaneously. Using both braking systems will stop your ATV faster with greater stability.

To slow or stop, apply the brake lever and brake pedal smoothly, while downshifting to match your speed when your ATV is in the ESP mode.

Gradually increase braking as you feel the brakes slowing your speed. The increase in engine compression from downshifting will help slow your vehicle when your ATV is in the ESP mode.

Applying the brakes too hard may cause the wheels to lock and slide, reducing control of your ATV. If this happens, release the brake controls, steer straight ahead until you regain control, then reapply the brakes more gently.

When possible, reduce your speed or complete braking before entering a turn. Avoid braking or closing the throttle quickly while turning. Either action may cause one or more wheels to slip and reduce your control of your ATV.

Braking

Your ability to brake in a turn and to brake hard in an emergency situation are important riding skills.

When descending a long, steep grade, use engine compression braking by downshifting (in the ESP mode), with intermittent use of both brakes. Continuous brake application can overheat the brakes and reduce their effectiveness.

Riding with your foot resting on the brake pedal or your hands on the brake levers may overheat the brakes, reducing effectiveness.

For information on how to apply the brakes in various riding situations, see the following section, *Riding Your ATV*.

Riding Your ATV

Making Turns

Learn how to turn your ATV properly. Practice the techniques outlined in this section on level ground and at low speeds until you are confident in making turns.

WARNING

Turning improperly can make the ATV to go out of control, causing a collision or overturn.

- Always follow proper procedures for turning as described in this owner's manual.
- Practice turning at low speeds before attempting to turn at faster speeds.
- Do not turn at excessive speeds.

Riding Your ATV

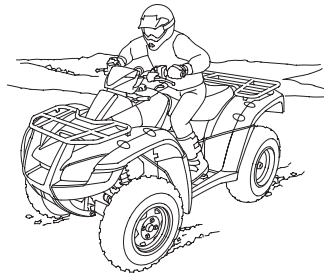
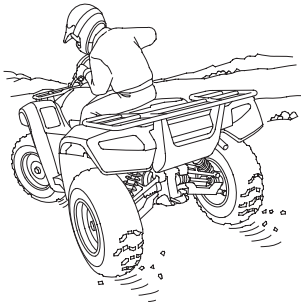

Lean your body to the inside of a turn and forward.

To make a turn on level ground: Steer the handlebar and lean your body toward the inside of the turn. Leaning helps balance the vehicle, and it feels more comfortable. Leaning into a turn is an important technique to master in riding an ATV.

To make a sharp turn at low speed: It helps to shift your body slightly forward on the seat, and lean inside, as you steer the handlebar. Shifting weight forward allows the rear wheels to turn easier, and it also improves front-wheel steering.

To make a turn from a full stop: Apply the throttle gradually when you turn and start up at the same time. Remember to shift your body forward to make sharp low-speed turns and whenever you turn while accelerating from a full stop.

Riding Your ATV

Skidding or Sliding

The terrain surface can be a major factor affecting turns. Skidding during a turn is more likely to occur on slippery surfaces, such as snow, ice, mud and loose gravel. If you skid on ice, you may lose all directional control. To avoid skidding on slippery terrain, keep your speed low and ride with caution.

WARNING

Skidding or sliding improperly may cause you to lose control of this ATV. You may also regain traction unexpectedly, which may cause the ATV to overturn.

Learn to safely control skidding by practicing at low speeds and on level, smooth terrain.

If your ATV skids sideways during a turn, steer in the direction of the skid. Avoid hard braking or accelerating until you have regained directional control.

Riding Your ATV

Riding Up Hills

The ATV's ability to safely climb hills largely depends on the rider's skill and judgment. Begin by practicing on smooth, gentle slopes. As you gain experience, you'll learn the hazards and your own limitations. You may then proceed to ride on more difficult terrain. However, you must be able to decide which hills or hazards might cause the ATV to overturn. Avoid excessively steep hills.

WARNING

Operating on excessively steep hills can cause the vehicle to overturn more easily than operating on level surfaces or small hills.

Never operate the ATV on hills too steep for the ATV or for your abilities.

When climbing hills, you must shift weight toward the front wheels to help keep them on the ground. To do this, shift your body slightly forward on the seat and lean forward. For greater weight shift, move your body farther forward and lean forward.

WARNING

Climbing hills improperly could cause loss of control or cause the ATV to overturn.

Always follow proper procedures for climbing hills as described in this owner's manual.

Riding Your ATV

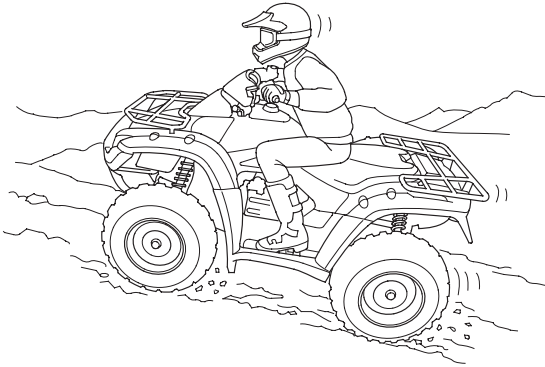

Shift weight forward when climbing hills.

- Always check the terrain carefully before you start up any hill.
- Never climb hills with excessively slippery or loose surfaces.
- To climb a hill, take a running start in an appropriate gear and speed for the conditions. Maintain a steady speed as you ascend the hill.
- Never open the throttle suddenly or make sudden gear changes. The ATV could flip over backward.
- Never go over the top of any hill at high speed. An obstacle, a sharp drop, or another vehicle or person could be on the other side of the hill.

Riding Your ATV

Stalling the ATV and/or Rolling Backwards:

If you incorrectly estimate climbing capability or terrain conditions, the ATV may not have enough power or traction to continue uphill. If this happens, the ATV can stall and/or roll backwards.

WARNING

Stalling, rolling backwards or improperly dismounting while climbing a hill could result in the ATV overturning.

Always follow proper procedures for climbing a hill as described in this owner's manual.

What to do if the ATV stalls or rolls backwards when climbing a hill:

If you are about to lose all forward speed:

1. Using the front and rear brakes together, bring the ATV to a stop with the vehicle pointed straight uphill.
2. Get off the ATV while you continue holding the brakes.
3. Shift into neutral, set the parking brake and turn the engine off.
4. Then assess the situation.

If the ATV starts rolling backwards before you begin braking:

1. Keep your weight uphill.
2. Carefully apply the front brakes first, then carefully apply the rear brake. Do not apply either brake abruptly if you are rolling backwards, or the vehicle may overturn.

If the ATV continues sliding backwards:

After you've applied the brakes, get off and away from the vehicle.

Remember that operating any brake control in the 4WD mode will cause braking at both the front and rear wheels.

Riding Your ATV

What to do after the ATV has stalled or rolled backwards:

If the hill is too steep or too slippery, or if you have any doubt whether you can safely walk the ATV back down the hill, leave the vehicle where it is and get help. If possible, block the wheels so the vehicle doesn't roll backwards.

If the hill is not too steep and you have good footing, you may be able to walk the ATV back down the hill. Make sure your intended path is clear in case you lose control of the ATV.



Be sure your legs are clear of the wheels.

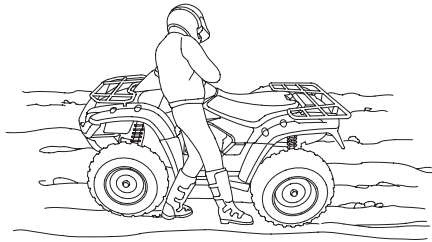

Body position for backing down a hill.

1. Stand with your body facing downhill, beside the vehicle so you can reach the rear brake lever with your right hand.
2. Be sure your legs are clear of the wheels.
Check your footing.
3. Slowly and carefully back the ATV down the hill using the rear brake lever to control speed.
4. If you lose control of the ATV, for your safety, get away from the vehicle.

Riding Your ATV

Riding Down Hills

It's usually advisable to descend hills with the ATV pointed straight downhill. Avoid angles that would cause the vehicle to lean sharply to one side.

WARNING

Going down a hill improperly could cause loss of control or cause the ATV to overturn.

Always follow proper procedures for going down hills as described in this owner's manual.

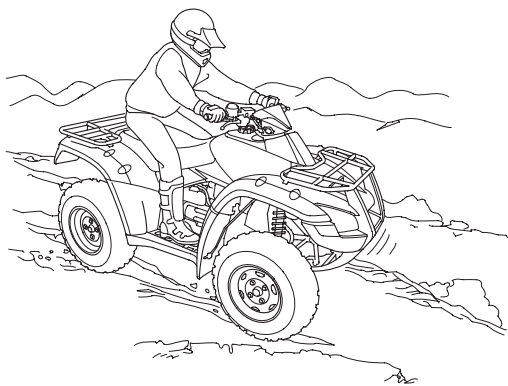

On downhills, shift your weight back.

As you approach a downhill, stop and survey the terrain below. Never ride past the limit of your visibility. Never go down a hill at high speed.

Riding Your ATV

When you've selected a safe downhill path, shift into a lower gear (in the ESP mode), shift your weight back with your arms extended and braced against the handlebar, then go down slowly with the throttle closed.

Use mainly the rear brake to control speed. Avoid using either the front brake or rear brake hard or abruptly when riding down hills.

Remember that operating any brake control in the 4WD mode will cause braking at both the front and rear wheels.

Remember, braking effectiveness is reduced on any hill with a loose surface.

Crossing or Turning on Hills or Slopes

Riding on hills or slopes is different from riding on level terrain. Be careful when riding on any hill. Make sure that you practice on gentle, smooth slopes before attempting to ride on steeper or more difficult terrain.

WARNING

Improperly crossing hills or turning on hills could cause loss of control or cause the ATV to overturn.

Always follow proper procedures for crossing or turning on slopes as described in this Owner's Manual. Avoid crossing steep hills if possible.

Riding Your ATV

Crossing Hills or Slopes

- To maintain balance and stability when riding across a slope, you need to shift weight toward the uphill side of the vehicle. To do this, move your body off the center of the seat and lean toward the uphill side.
- On a slippery or loose surface, you may also need to steer slightly uphill to maintain a straight course across the slope.
- Avoid crossing hills that are excessively steep, slippery or rough.



Shift weight uphill when crossing slopes.

Making Turns on Slopes

- Compared to riding on level ground, you may need to shift more weight and lean more when making turns on slopes.
- Do not make turns on any slopes until you have first mastered the techniques for making turns on level terrain.

Riding Your ATV

Riding Over Obstacles

Before operating in a new area, check for obstacles. Watch out for bumps, rain ruts, potholes and other obstacles in the terrain. When you approach any obstacle, reduce your speed and be prepared to stop. Never try to ride over large obstacles, such as large rocks or fallen logs.

WARNING

Improperly operating over obstacles could cause loss of control or a collision and could cause the ATV to overturn.

When you go over obstacles, always follow proper procedures as described in this owner's manual.

Riding Your ATV

Riding Through Water

Your ATV is designed to travel through water up to approximately 10 inches (254 mm) deep. Before crossing a stream, make sure the water is not too deep or flowing too fast.

WARNING

The ATV tires have some ability to float. Operating this ATV through deep or fast-flowing water may cause a loss of traction and loss of control, which could lead to an accident.

Never operate this ATV in fast-flowing water or in water deeper than that specified in this Owner's Manual.

1. Choose a path where both banks have gradual slopes.
2. Proceed through the water at a slow, steady speed.
3. Watch out for submerged obstacles and slippery rocks.
4. Avoid getting the spark plug or air cleaner wet, as this would cause the engine to stop.
5. After leaving the water, always test both the front and rear brakes.
 - Riding through water can make the brakes less effective than normal, and may reduce stopping ability.
 - If necessary, apply the brakes repeatedly until they dry out and operate normally.

Parking

1. Look for level parking area. Make sure the ground surface is firm.
2. After bringing your ATV to a stop, hold the brakes while you shift into neutral.
3. Set the parking brake.
4. Turn the ignition switch OFF ().

If it is necessary to start the engine when your ATV is stopped on a grade in gear, rock the vehicle back and forth to allow shifting the transmission into neutral.

The brakelights are activated by applying the parking brake. When using the parking brake, be sure to turn the ignition switch OFF () to avoid discharging the battery.

Parking on a Steep Incline or a Loose or Slippery Surface

If you must park your ATV on a steep incline or loose or slippery surface, use the following procedure:

1. While holding the brakes, set the parking brake.
2. Turn the ignition switch OFF () and release the brakes.
3. If the ATV begins to move, either while sitting on it or after you dismount, find a better parking location.
4. If rocks or other objects are available, you can block the wheels as shown for additional security.

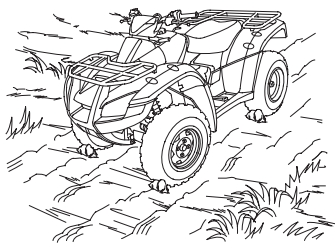

Servicing Your Honda

To help keep your ATV in good shape, this section includes a Maintenance Schedule for required service and step-by-step instructions for specific maintenance tasks. You'll also find important safety precautions, information on fuels and oils, and tips for keeping your Honda looking good.

For information about replacing fuses, see page 224 .

For information about the exhaust emission and noise requirements of the U.S. Environmental Protection Agency (EPA) and the California Air Resources Board (CARB), see page 241 .

USA Only

Maintenance, replacement or repair of the emission control devices and systems may be performed by any ATV repair establishment or individual using parts that are “certified” to EPA standards.

Before You Service Your Honda

The Importance of Maintenance	127
Maintenance Safety	128
Important Safety Precautions	129
Maintenance Schedule	130
Maintenance Record.....	134

Service Preparations

Maintenance Component Locations	135
Tool Kit.....	138
Owner's Manual Storage.....	139
Seat Removal	140

(cont'd)

Service Your Honda

Service Procedures

Fluids & Filters

Fuel	141
Engine Oil & Filter.....	144
Gear Case Oil	152
Differential Oil.....	154
Coolant	156
Air Cleaner	161

Engine

Throttle.....	166
Spark Plug	168
Valves.....	171
Spark Arrester	172

Chassis

Brakes.....	174
Tires	182
Engine Guards & Skid Plates	189
Driveshaft Boots	190

Electrical

Battery.....	191
--------------	-----

Appearance Care	196
-----------------------	-----

The Importance of Maintenance

A well-maintained ATV is essential for safe, economical, and trouble-free riding. It will also help reduce air pollution. Careful pre-ride inspections and good maintenance are especially important because your ATV is designed to be ridden over rough off-road terrain.

To help you properly care for your ATV, this section of the manual provides a Maintenance Schedule. The service intervals in this schedule are based on average riding conditions.

WARNING

Improperly maintaining this ATV or failing to correct a problem before you ride can cause a crash in which you can be seriously hurt or killed.

Always follow the inspection and maintenance recommendations and schedules in this owner's manual.

Frequent servicing of the air cleaner is especially important to help you avoid a possible costly engine repair.

If your ATV overturns or is involved in a crash, be sure your Honda dealer inspects all major parts, even if you are able to make some repairs.

Maintenance Safety

This section includes instructions on how to perform some important maintenance tasks. If you have basic mechanical skills, you can perform many of these tasks with the tools provided with your ATV.

Other tasks that are more difficult and require special tools are best performed by professionals. Removing the wheels should normally be handled only by a Honda technician or other qualified mechanic. Instructions are included in this manual only to assist in emergency service.

Some of the most important safety precautions follow. However, we cannot warn you of every conceivable hazard that can arise in performing maintenance. Only you can decide whether or not you should perform a given task.

WARNING

Failure to properly follow maintenance instructions and precautions can cause you to be seriously hurt or killed.

Always follow the procedures and precautions in this owner's manual.

Maintenance Safety

Important Safety Precautions

- Make sure the engine is off before you begin any maintenance or repairs. This will help eliminate several potential hazards:
 - Carbon monoxide poisoning from engine exhaust.** Be sure there is adequate ventilation whenever you operate the engine.
 - Burns from hot ATV parts.** Let the engine and exhaust system cool before touching.
 - Injury from moving parts.** Do not run the engine unless instructed to do so.
- Read the instructions before you begin, and make sure you have the tools and skills required.
- To reduce the possibility of a fire or explosion, be careful when working around gasoline. Use only non-flammable solvent, not gasoline, to clean parts. Keep cigarettes, sparks, and flames away from all fuel-related parts.

Remember that your Honda dealer knows your ATV best and is fully equipped to maintain and repair it. To ensure the best quality and reliability, use only new genuine Honda parts or other equivalents for repair and replacement. If you have the tools and skills required for additional maintenance jobs, you can purchase an official Honda Service Manual (page 248).

Maintenance Schedule

The required Maintenance Schedule that follows specifies how often you should have your ATV serviced, and what things need attention. It is essential to have your ATV serviced as scheduled to maintain safe, dependable performance and proper emission control.

The service intervals in this Maintenance Schedule are based on average riding conditions. Some items will need more frequent service if you ride in unusually wet or dusty areas or at full throttle. Consult your Honda dealer for recommendations applicable to your individual needs and use.

Some items in the Maintenance Schedule can be performed with basic mechanical skills and hand tools. Procedures for these items are provided in this manual. Other items involve more extensive procedures and may require special training, tools, and equipment. We recommend that you have your Honda dealer perform these tasks unless you have advanced mechanical skills and the required tools and equipment. Procedures for such items in this schedule are provided in an official Honda Service Manual available for purchase (page 248).

If you do not feel capable of performing a given task or need assistance, remember that your Honda dealer knows your ATV best and is fully equipped to maintain and repair it. If you decide to do your own maintenance, use only genuine Honda parts or their equivalents for repair or replacement to ensure the best quality and reliability.

Maintenance Schedule

Perform the pre-ride inspection (page 79) and owner maintenance on this section at each scheduled maintenance period.

Each item on the maintenance schedule requires some mechanical knowledge. Certain items (particularly those marked * and **) may require more technical information and tools. Consult your Honda dealer.

- * Should be serviced by your Honda dealer, unless you have the proper tools and service data and are mechanically qualified. Refer to the official Honda Service Manual (page 248).
- ** In the interest of safety, we recommend these items be serviced only by your Honda dealer.

Summary of Maintenance Schedule Notes & Procedures:

NOTES:

1. Service more frequently when riding in dusty areas, sand or snow.
2. Service more frequently after riding in very wet or muddy conditions.
3. Replace every 2 years. Replacement requires mechanical skill.

Maintenance Schedule

Maintenance Procedures:

I: inspect and clean, adjust, lubricate, or replace, if necessary

C: clean

A: adjust

L: lubricate

R: replace

ITEMS	FREQUENCY	WHICHEVER COMES FIRST		INITIAL MAINT.	REGULAR MAINT. INTERVAL		Refer to page
		mi ⇔ HOURS	km	100	600	1200	
				150	1000	2000	
		NOTE		20	100	200	
*	FUEL LINE				I		—
*	THROTTLE OPERATION				I		166
	AIR CLEANER	NOTE 1			C	C	161
	AIR CLEANER HOUSING DRAIN TUBE	NOTE 2			I	I	165
	SPARK PLUG					I	168
*	VALVE CLEARANCE			I	I	I	171
	ENGINE OIL			INITIAL= 100 mi (150 km), 20 operating hours or 1 month: R REGULAR= Every 600 mi (1,000 km), 100 operating hours or 12 months: R			144
	ENGINE OIL FILTER			R	R	R	149
	RADIATOR COOLANT	NOTE 3			I	I	156
*	COOLING SYSTEM	NOTE 2			I	I	—

* Should be serviced by your Honda dealer, unless you have the proper tools and service data and are mechanically qualified. Refer to the official Honda Service Manual (page 248).

Maintenance Schedule

ITEMS	FREQUENCY	WHICHEVER COMES FIRST		INITIAL MAINT.	REGULAR MAINT. INTERVAL		Refer to page
		mi ⇔ km	HOURS	100	600	1200	
				150	1000	2000	
		NOTE		20	100	200	
	DRIVE SHAFT BOOTS						190
	REAR FINAL GEAR CASE OIL AND DIFFERENTIAL OIL				(R:EVERY 2 YEARS)		152 154
*	BRAKE FLUID	NOTE 3					174
*	BRAKE PADS WEAR	NOTE 1,2					177
*	BRAKELIGHT SWITCH						181
	BRAKE SYSTEM						174
	SKID PLATE, ENGINE GUARD						189
*	SUSPENSION						—
*	SPARK ARRESTER				C	C	172
*	NUTS, BOLTS, FASTENERS						—
**	WHEELS/TIRES						—
**	STEERING SHAFT HOLDER BEARINGS						—
**	STEERING SYSTEM						—

* Should be serviced by your Honda dealer, unless you have the proper tools and service data and are mechanically qualified. Refer to the official Honda Service Manual (page 248).

** In the interest of safety, we recommend these items be serviced only by your Honda dealer.

Maintenance Record

Keeping an accurate maintenance record will help ensure that your ATV is properly maintained. Retain detailed receipts to verify the maintenance was performed. If the ATV is sold, these receipts should be transferred with the ATV to the new owner. Make sure whoever performs the maintenance completes this record. All scheduled maintenance, including the 100 mile (150 km) or 20 hours initial maintenance, is considered a normal owner operating cost and will be charged for by your dealer. Use the space under Notes to record anything you want to remind yourself about or mention to your dealer.

Miles (km) or hours	ODO or HOUR	Date	Performed By:	Notes
100 (150) or 20				
600 (1,000) or 100				
1,200 (2,000) or 200				
1,800 (3,000) or 300				
2,400 (4,000) or 400				
3,000 (5,000) or 500				
3,600 (6,000) or 600				
4,200 (7,000) or 700				
4,800 (8,000) or 800				

Maintenance Component Locations

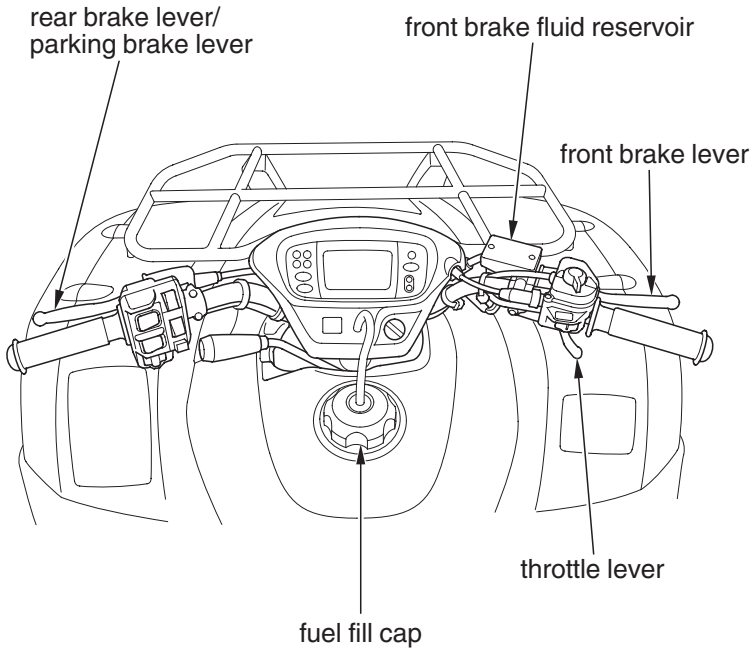

Maintenance Component Locations

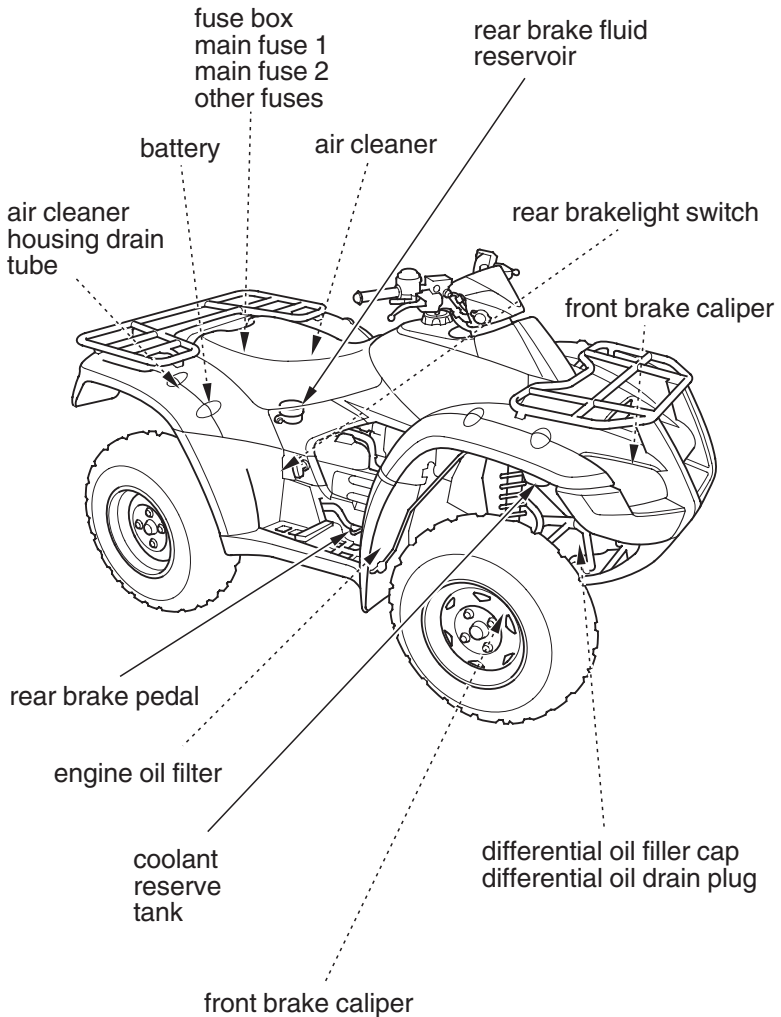

Maintenance Component Locations

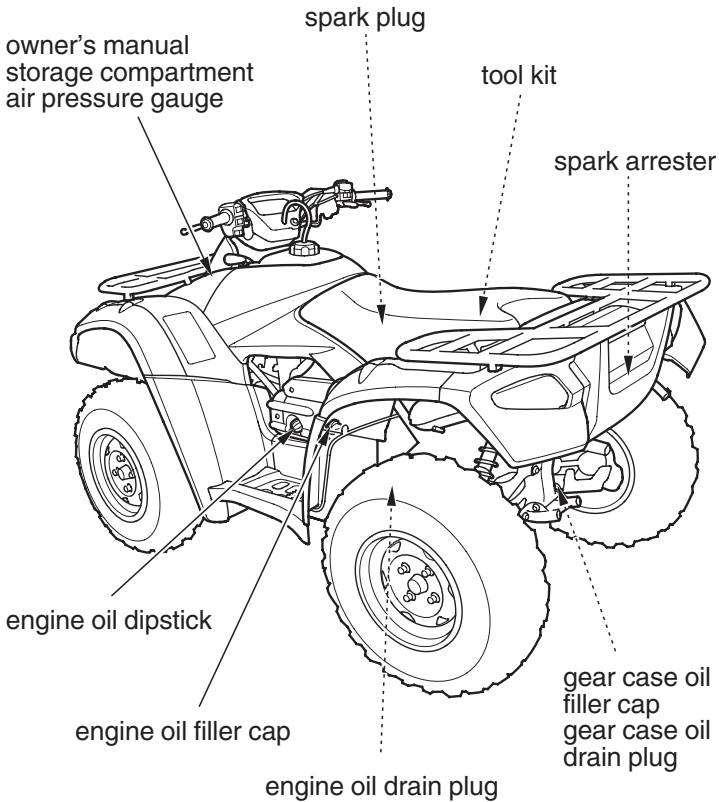

Tool Kit

The tool kit (1) is stored in the tool kit compartment (2) under the seat. After using the tools, be sure to use the rubber band (3) to fasten the tool kit securely.

An optional, larger tool kit may be available. Check with your Honda dealer's parts department.

UNDER SEAT

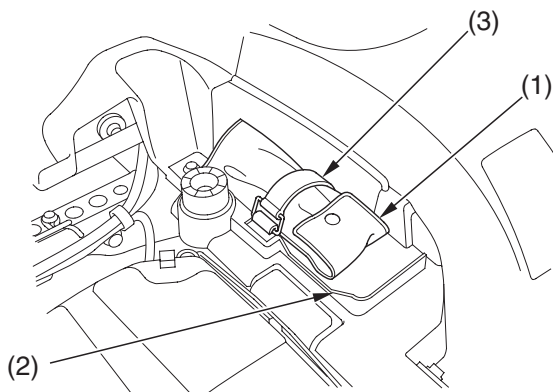

(1) tool kit
(2) tool kit compartment

(3) rubber band

Owner's Manual Storage

Your ATV provides storage for the owner's manual so you'll have it with you for easy reference. Store your owner's manual (1) in the storage compartment (2) at the left side of the front fender.

To open the compartment, turn left the quick screw (3) and remove the lid (4).

The owner's manual and air pressure gauge (5) should be stored in the plastic bag (6) and fastened with the rubber band (7).

Be careful not to flood this area when washing your ATV.

LEFT

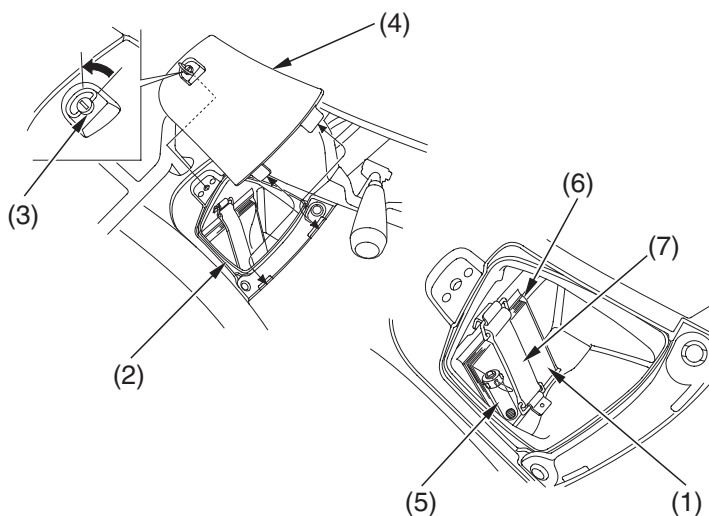

- (1) owner's manual
- (2) storage compartment
- (3) quick screw
- (4) lid

- (5) air pressure gauge
- (6) plastic bag
- (7) rubber band

Seat Removal

Refer to *Safety Precautions* on page 129.

The seat must be removed for the air cleaner, spark plug, and fuse maintenance.

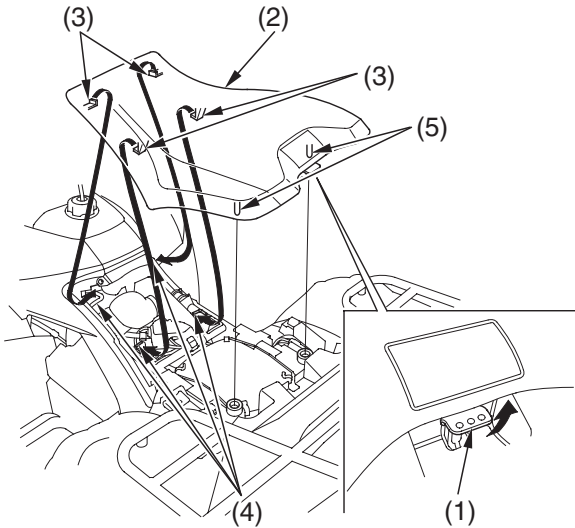

(1) seat latch
(2) seat
(3) front prongs

(4) hooks
(5) studs

Removal

1. Pull the seat latch (1) at the rear of the seat.
2. Slide the seat (2) back and lift it.

Installation

1. Insert the front prongs (3) into the hooks (4) and press the studs (5) into the grommets on the rear fender.
2. Press down on the seat until locks.

Refer to *Safety Precautions* on page 129.

Fuel Recommendation

type	unleaded
pump octane number	86 (or higher)

We recommend that you use unleaded fuel because it produces fewer engine deposits and extends the life of exhaust system components.

Your engine is designed to use any gasoline that has a pump octane number of 86 or higher. Gasoline pumps at service stations normally display the pump octane number. For information on the use of oxygenated fuels, see page 245 .

Use of lower octane gasoline can cause persistent “pinging” or “spark knock” (a loud rapping noise) which, if severe, can lead to engine damage. Light pinging experienced while operating under a heavy load, such as climbing a hill, is no cause for concern.

If pinging or spark knock occurs at a steady engine speed under normal load, change brands of gasoline. If pinging or spark knock persists, consult your Honda dealer.

Never use stale or contaminated gasoline or an oil/gasoline mixture. Avoid getting dirt, dust, or water in the fuel tank.

Fuel

Fuel Capacity

Fuel tank capacity:
4.49 US gal (17.0 l)

The tank should be refilled as soon as possible when the E segment in the fuel gauge flashes.

Refueling Procedure

Refer to *Safety Precautions* on page 129.

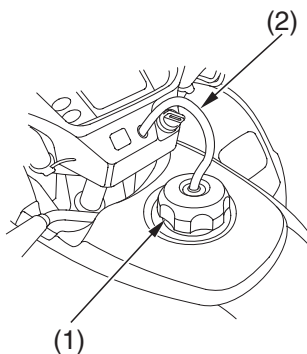

- (1) fuel fill cap
- (2) breather tube

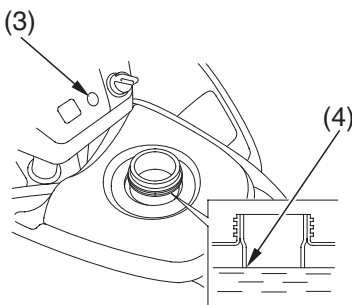

- (3) handlebar cover hole
- (4) filler neck

1. To open the fuel fill cap (1), turn it counterclockwise.
2. Pull the breather tube (2) out of the handlebar cover hole (3).
3. Add fuel until the level reaches the bottom of the filler neck (4).

Avoid over filling the tank. There should be no fuel in the filler neck.

WARNING

Gasoline is highly flammable and explosive. You can be burned or seriously injured when handling fuel.

- Stop the engine and keep heat, sparks and flame away.
- Handle fuel only outdoors.
- Wipe up spills immediately.

4. After refueling, turn the fuel fill cap clockwise until it clicks.
5. Insert the breather tube into the handlebar cover hole.

If you replace the fuel fill cap, use only a genuine Honda replacement part.

Engine Oil & Filter

Engine oil quality is a major factor that affects both the performance and the service life of the engine.

Using the proper oil (page 145) and filter, and regularly checking, adding, and changing oil will help extend your engine's life. Even the best oil wears out. Changing oil helps get rid of dirt and deposits in the engine. Operating the engine with old or dirty oil can damage your engine. Running the engine with insufficient oil can cause serious damage to the engine and transmission.

Change the engine oil as specified in the maintenance schedule on page 130 . When running in very dusty conditions, oil changes should be performed more frequently than specified in the maintenance schedule.

Engine Oil & Filter

Oil Recommendation

API classification	SG or higher except oils labeled as energy conserving on the circular API service label
viscosity (weight)	SAE 10W-30
JASO T 903 standard	MA
suggested oil*	Pro Honda GN4 or HP4 (without molybdenum additives) 4-stroke oil (USA & Canada), or Honda 4-stroke oil (Canada only), or an equivalent motorcycle oil

* Suggested oils are equal in performance to SJ oils that are not labeled as energy conserving on the circular API service label.

- Your ATV does not need oil additives. Use the recommended oil.
- Do not use oils with graphite or molybdenum additives. They may adversely affect clutch operation.
- Do not use API SH or higher oils displaying a circular API “energy conserving” service label on the container. They may affect lubrication and clutch performance.



NOT RECOMMENDED



OK

- Do not use non-detergent, vegetable, or castor based racing oils.

(cont'd)

Engine Oil & Filter

Other viscosities shown in the following chart may be used when the average temperature in your riding area is within the indicated range.

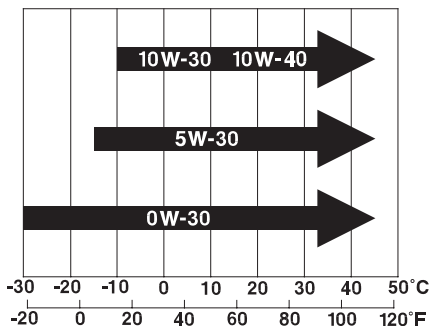

JASO T 903 standard

The JASO T 903 standard is an index for engine oils for 4-stroke motorcycle engines.

There are two classes: MA and MB.

Oil conforming to the standard is labeled on the oil container. For example, the following label shows the MA classification.

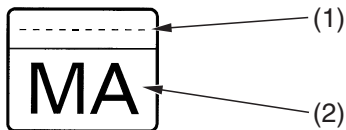

PRODUCT MEETING JASO T 903
COMPANY GUARANTEEING THIS MA PERFORMANCE:

- (1) code number of the sales company of the oil
- (2) oil classification

Engine Oil & Filter

Checking & Adding Oil

Refer to *Safety Precautions* on page 129.

Check the engine oil level each day before operating your ATV and add if needed.

1. Park your ATV on a firm, level surface.
2. Start the engine in a well-ventilated area and let it idle for 3–5 minutes. Stop the engine and wait 2–3 minutes.
3. Remove the dipstick (1) from the front crankcase cover and wipe it clean.
4. Insert the dipstick without screwing it in, then remove the dipstick and check the oil level. The oil level should be between the upper level mark (2) and the lower level mark (3) on the dipstick.

LEFT SIDE

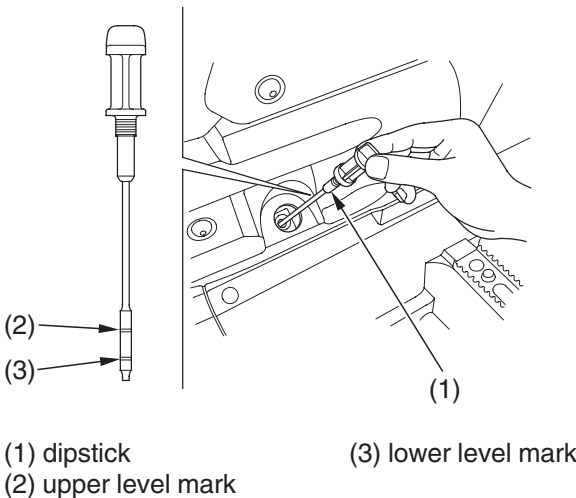

(1) dipstick
(2) upper level mark

(3) lower level mark

Engine Oil & Filter

- If required, remove the oil filler cap lid (4) and oil filler cap (5) and add the specified oil into the filler cap hole, up to the upper level mark on the dipstick. Do not overfill.
- Reinstall the oil filler cap, oil filler cap lid and dipstick.

NOTICE

Running the engine with an improper oil level can cause serious engine damage.

LEFT SIDE

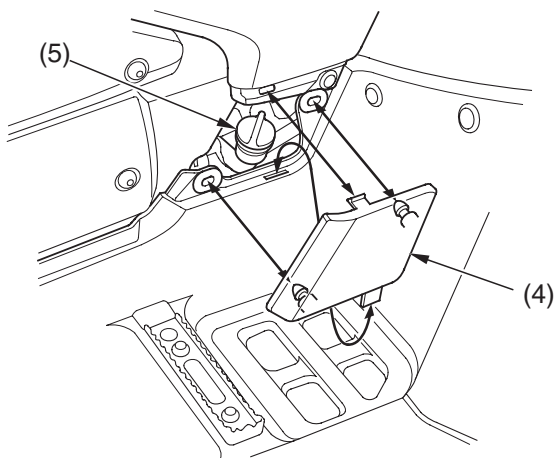

(4) oil filler cap lid

(5) oil filler cap

Engine Oil & Filter

Changing Engine Oil & Filter

Refer to *Safety Precautions* on page 129.

Your ATV's oil filter has very specific performance requirements. Use a new genuine Honda oil filter specified for your model or a filter of equal quality.

NOTICE

Using the wrong oil filter may result in leaks or premature engine damage.

This procedure requires mechanical skill and professional tools such as a torque wrench and oil filter wrench, as well as a means for disposing of the drained fluid (page 210). If you do not have the skills or the tools, see your Honda dealer.

Drain the Engine Oil:

1. With the ATV on level ground, remove the oil filler cap from the left side of crankcase.
2. Place an oil drain pan under the crankcase and remove the engine oil drain plug (1).

UNDER ENGINE

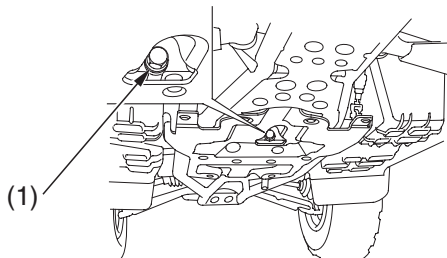

(1) engine oil drain plug

Engine Oil & Filter

Install a New Engine Oil Filter:

3. Remove the oil filter bolt (2) and oil filter cover (3).
Let the remaining oil drain out.
4. Remove the oil filter (4) from the cover.
5. Remove the spring and washer. Do not discard the washer with the old oil filter.
6. Discard the oil filter.
7. Check the O-rings (5) are in good condition and then insert a new oil filter to the oil filter cover.
Use only the Honda genuine oil filter or a filter of equivalent quality specified for your model. Using the wrong Honda filter or a non-Honda filter which is not of equivalent quality may cause engine damage.
8. Install the oil filter cover and tighten the oil filter bolt. Make sure the oil filter bolt is tightened securely to the specified torque.
Oil filter bolt torque:
13 lbf-ft (18 N·m , 1.8 kgf·m)

NOTICE

Improper installation of the oil filter can cause serious engine damage.

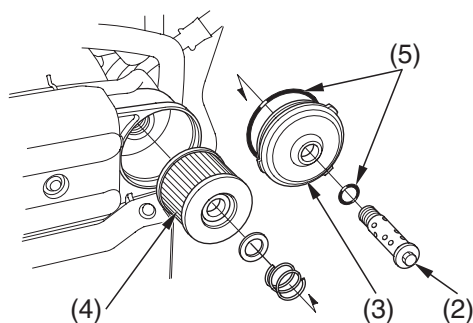

(2) oil filter bolt
(3) oil filter cover

(4) oil filter
(5) O-rings

Engine Oil & Filter

- Pour the drained oil into a suitable container and dispose of it in an approved manner (page 210).

NOTICE

Improper disposal of drained fluids is harmful to the environment.

Add Engine Oil:

- Check that the drain plug sealing washer (6) and O-ring (7) are in good condition. If necessary, replace them.

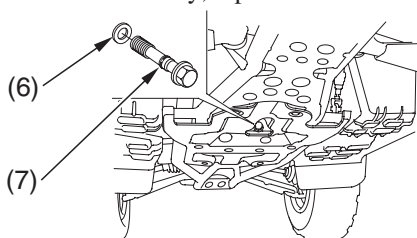

(6) drain plug sealing washer

(7) O-ring

- Apply a thin coat of engine oil to the O-ring.
- Reinstall the engine oil drain plug and tighten it to the specified torque:
18 lbf·ft (25 N·m , 2.5 kgf·m)
- Fill the crankcase with the recommended grade oil approximately:
3.1 US qt (2.9 ℓ)
- Reinstall the oil filler cap.
- Start the engine and let it idle for 5 minutes.
- Stop the engine and after 2—3 minutes, check the oil level. Make sure the oil is between the upper and lower level marks on the dipstick.
If necessary , add more oil but do not overfill.
- Reinstall the oil filler cap and dipstick.
- Check that there are no oil leaks.
If a torque wrench is not used for installation, see your Honda dealer as soon as possible to verify proper assembly.

Gear Case Oil

Oil Recommendation

type	hypoid gear oil
viscosity (weight)	SAE 80
suggested oil	Honda shaft drive oil or equivalent

Changing Oil

Refer to *Safety Precautions* on page 129.

Changing the oil with the gear case at normal operating temperature to assure complete and rapid draining.

Gear Case Oil

1. Park the ATV on level ground.
2. Place an oil drain pan under the oil drain plug (1).
3. Remove the oil filler cap (2) and the drain plug.
4. After the oil has completely drained, reinstall the drain plug and tighten it to the specified torque:
9 lbf·ft (12 N·m , 1.2 kgf·m)
5. Fill the gear case with the recommended oil.
2.6 US oz (78 cm³)
6. Make sure the oil level is at the lower edge of the inspection hole (3).
7. Install the oil filler cap.

REAR

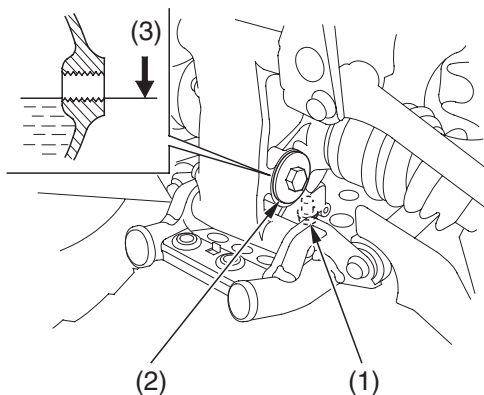

- (1) oil drain plug
- (2) oil filler cap
- (3) lower edge of the inspection hole

Differential Oil

Oil Recommendation

type	hypoid gear oil
viscosity (weight)	SAE 80
suggested oil	Honda shaft drive oil or equivalent

Changing Oil

Refer to *Safety Precautions* on page 129.

Changing the oil with the differential at normal operating temperature to assure complete and rapid draining.

Differential Oil

1. Park the ATV on level ground.
2. Place an oil drain pan under the oil drain plug (1).
3. Remove the oil filler cap (2) and the drain plug.
4. After the oil has completely drained, reinstall the drain plug and tighten it to the specified torque:
9 lbf·ft (12 N·m , 1.2 kgf·m)
5. Fill the differential with the recommended oil.
5.9 US oz (175 cm³)
Make sure the oil level is at the lower edge of the inspection hole (3).
6. Install the oil filler cap.

FRONT

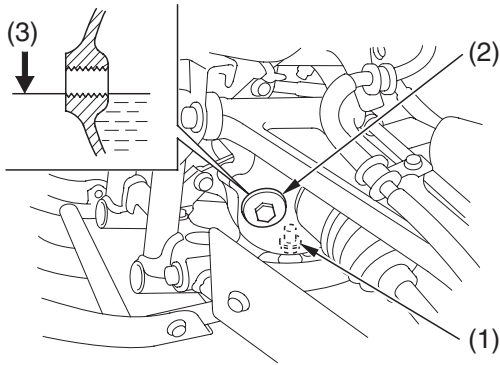

- (1) oil drain plug
- (2) oil filler cap
- (3) lower edge of the inspection hole

Coolant

Your ATV's liquid cooling system dissipates engine heat through the coolant jacket that surrounds the cylinder and cylinder head.

Maintaining the coolant will allow the cooling system to work properly and prevent freezing, overheating, and corrosion.

Coolant Recommendation

Use Pro Honda HP coolant or an equivalent high quality ethylene glycol antifreeze containing corrosion protection inhibitors specifically recommended for use in aluminum engines. Check the antifreeze container label.

Use only distilled water as a part of the coolant solution. Water that is high in mineral content or salt may be harmful to the aluminum engine.

NOTICE

Using coolant with silicate inhibitors may cause premature wear of water pump seals or blockage of radiator passages. Using tap water may cause engine damage.

The factory provides a 50/50 solution of antifreeze and water in this ATV. This coolant solution is recommended for most operating temperatures and provides good corrosion protection.

Decreasing the concentration of antifreeze to less than 40% will not provide proper corrosion protection.

Coolant

Increasing the concentration of antifreeze is not recommended because it decreases cooling system performance. Higher concentrations of antifreeze (up to 60%) should only be used to provide additional protection against freezing. Check the cooling system frequently during freezing weather.

Checking & Adding Coolant

Refer to *Safety Precautions* on page 129.

Check the engine coolant level each day before operating your ATV and add if needed.

RIGHT FRONT

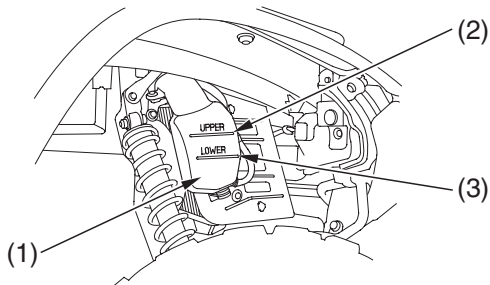

(1) reserve tank

(3) LOWER level mark

(2) UPPER level mark

1. Make sure the vehicle is on level ground.
2. With the engine at normal operating temperature, check the coolant level in the reserve tank (1). It should be between UPPER (2) and LOWER (3) level marks.

If the reserve tank is empty, or if coolant loss is excessive, check for leaks and see your Honda dealer for repair.

(cont'd)

Coolant

3. Remove the steering cover (4) and reserve tank cap (5).

Always add coolant to the reserve tank. Do not attempt to add coolant by removing the radiator cap.

4. Add coolant to the reserve tank as required to bring the coolant level to the UPPER level mark.

FRONT

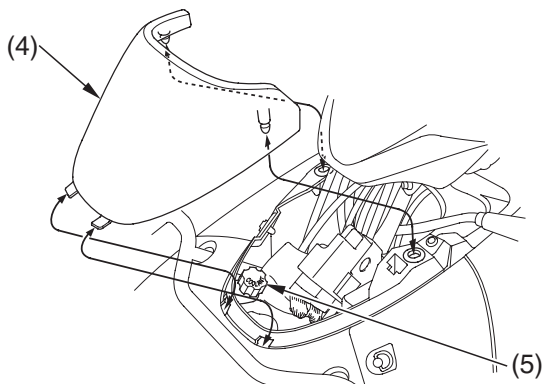

(4) steering cover

(5) reserve tank cap

5. After adding coolant, install the reserve tank cap and steering cover.

Coolant Replacement

Refer to *Safety Precautions* on page 129.

Coolant should be replaced by your Honda dealer, unless you have the proper tools and service data and are mechanically qualified. Refer to the official Honda Service Manual (page 248).

WARNING

Removing the radiator cap while the engine is hot can cause the coolant to spray out, seriously scalding you.

Always let the engine and radiator cool down before removing the radiator cap.

To properly dispose of drained coolant, refer to *You & the Environment*, page 210 .

NOTICE

Improper disposal of drained fluids is harmful to the environment.

Coolant

Radiator Core

Refer to *Safety Precautions* on page 129.

Check the air passages for clogging or damage. Remove insects, mud, or any obstruction with low water pressure. Have the radiator checked by your Honda dealer if the air flow is restricted over more than 20% of the radiator surface.

Clean the radiator core after riding the ATV in mud.

To clean the radiator core, oil cooler and radiator cover plate:

1. Unhook the tabs (1).
2. Remove the radiator cover plate (2).
3. Wash the radiator core (3), oil cooler (4) and radiator cover plate.

NOTICE

Do not apply pressured water directly to the radiator core and oil cooler. The pressured water can damage the radiator core.

FRONT

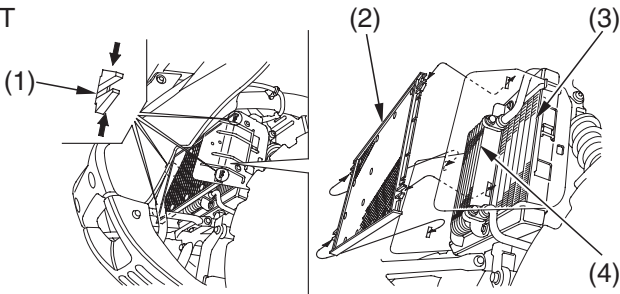

- (1) tabs
(2) radiator cover plate

- (3) radiator core
(4) oil cooler

Air Cleaner

Refer to *Safety Precautions* on page 129.

Proper air cleaner maintenance is very important for off-road vehicles. A dirty, water-soaked, worn-out, or defective air cleaner will allow dirt, dust, mud, and other impurities to pass into the engine.

Service the air cleaner more frequently if you ride in unusually wet or dusty areas. Your Honda dealer can help you determine the correct service interval for your riding conditions.

Your ATV's air cleaner has very specific performance requirements. Use a new genuine Honda air cleaner specified for your model or an air cleaner of equal quality.

NOTICE

Using the wrong air cleaner may result in premature engine damage.

Proper air cleaner maintenance can prevent premature engine wear or damage, expensive repairs, low engine power, poor gas mileage, and spark plug fouling.

NOTICE

Improper or lack of proper air cleaner maintenance can cause poor performance and premature engine wear.

Air Cleaner

Cleaning

1. Remove the seat by pulling the seat latch (1) up.

UNDER SEAT

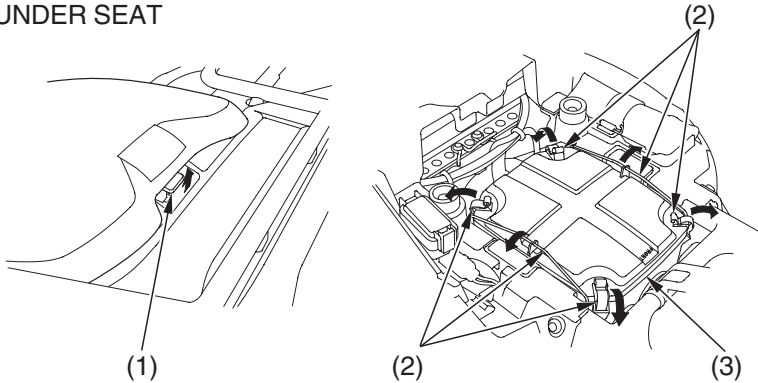

- (1) seat latch
- (2) retainer clips

- (3) air cleaner housing cover

2. Unlatch the retainer clips (2).
3. Remove the air cleaner housing cover (3).

Air Cleaner

4. Remove the element holder (4).
5. Loosen the screw (5) and remove the air cleaner assembly (6) from the air cleaner housing.
6. Unscrew the clamp (7).
7. Remove the air cleaner (8) from the air cleaner body (9).
8. Gently wash the air cleaner in clean, non-flammable (high flash point) solvent such as kerosene — not gasoline. After cleaning, gently squeeze out the remaining solvent. Avoid twisting or wringing the air cleaner. This can tear the foam.
9. Inspect for tears or cracks in the foam or seams of the air cleaner. Replace the air cleaner if it is damaged.

UNDER SEAT

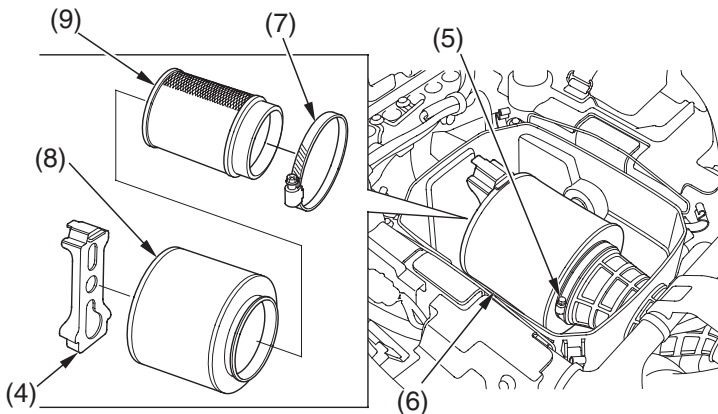

(4) element holder

(5) screw

(6) air cleaner assembly

(7) clamp

(8) air cleaner

(9) air cleaner body

(cont'd)

Air Cleaner

10. Allow the air cleaner to dry thoroughly before applying oil. A wet air cleaner will not fully absorb the oil.
11. Pour clean Pro Honda Foam Filter Oil or an equivalent (Canada: Honda Foam Filter Oil or an equivalent) over the entire surface of the air cleaner. Use both hands to evenly spread the oil into the air cleaner. Gently squeeze out any excess oil. (To keep your hands dry, place the air cleaner in a clean plastic bag before spreading the oil into the air cleaner.)
12. Install the air cleaner on the air cleaner body.
13. Apply a thin coat of grease to the sealing surface of the air cleaner assembly.
14. Install the clamp.
15. Insert the air cleaner assembly into the air cleaner housing.
16. Install the element holder.
17. Fasten the screw.
18. Reassemble by reversing the disassembly sequence.
 - Install the air cleaner housing cover with the FRONT mark (11) facing forward and fit the tab (12) at the element holder.

UNDER SEAT

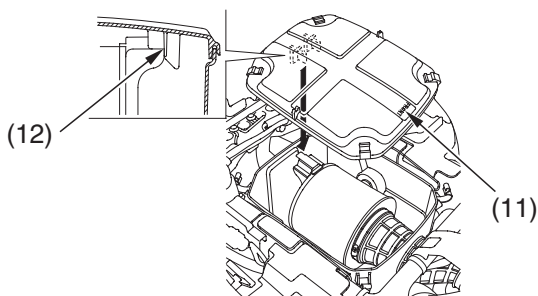

- (11) FRONT mark
(12) tab

Air Cleaner

Air Cleaner Housing Drain Tube

The air cleaner housing drain tube should be serviced in accordance with the Maintenance Schedule. (Riding through water may require more frequent inspection.) If deposits can be seen in the drain tube, the tube must be cleaned before starting the vehicle.

REAR

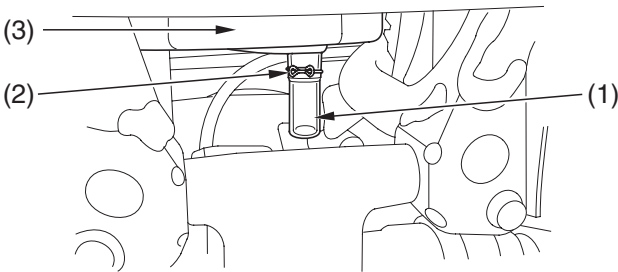

(1) drain tube
(2) clip

(3) air cleaner housing

1. Remove the drain tube (1) by removing the clip (2) under the air cleaner housing (3).
2. Drain the deposits.
3. Reinstall the drain tube, securing it with the clip.

Throttle

Throttle Freeplay

Refer to *Safety Precautions* on page 129.

RIGHT HANDLEBAR

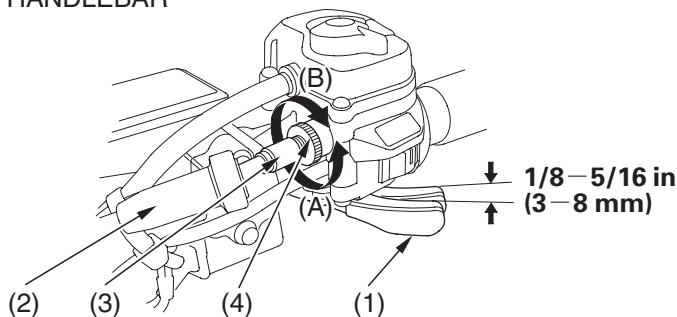

(1) throttle lever

(2) rubber sleeve

(3) throttle cable adjuster

(4) lock nut

(A) decrease freeplay

(B) increase freeplay

Inspection

Check freeplay at the throttle lever (1).

Freeplay:

1/8—5/16 in (3—8 mm)

Adjustment

1. Slide the rubber sleeve (2) back to expose the throttle cable adjuster (3).
2. Loosen the lock nut (4).
3. Turn the adjuster to obtain the correct freeplay.
4. Tighten the lock nut and reinstall the sleeve.
5. After adjustment, check for smooth operation of the throttle lever from fully closed to fully open in all steering positions.

Throttle Inspection

Refer to *Safety Precautions* on page 129.

1. Check that the throttle assembly is positioned properly and the securing bolts are tight.
2. Check for smooth operation of the throttle lever from fully open to fully closed in all steering positions. If there is a problem, see your Honda dealer.
3. Inspect the condition of the throttle cables from the throttle lever down to the PGM – FI. If the cable is kinked or chafed, have it replaced.
4. Check the cables for tension or stress in all steering positions.
5. Lubricate the cables with a commercially-available cable lubricant to prevent premature wear and corrosion.

Spark Plug

Spark Plug Recommendation

standard spark plug	IFR5L11 (NGK) or VK16PRZ11 (DENSO)
for extended high speed riding	IFR6L11 (NGK) or VK20PRZ11 (DENSO)

Use only the recommended type of spark plug in the recommended heat range.

NOTICE

Using spark plugs with an improper heat range can cause engine damage.

This ATV uses spark plugs that have an iridium coated center electrode. Be sure to observe the following when servicing the spark plugs.

- Do not clean the spark plugs. If an electrode is contaminated with accumulated objects or dirt, replace the spark plug with a new one.
- To check the spark plug gap, use only a “wire-type feeler gauge.” To prevent damaging the iridium coating of the center electrode, never use a “leaf-type feeler gauge.”

Spark Plug

Spark Plug Replacement & Inspection

Refer to *Safety Precautions* on page 129.

1. Remove the seat (page 140).
2. Loosen the screw (1) and remove the resonance chamber (2).
3. Unhook the rubber cover (3).
4. Clean any dirt from around the spark plug base.
5. Disconnect the spark plug cap (4). Take care to avoid damaging the spark plug wire when disconnecting the cap.
6. Using a spark plug wrench provided in the tool kit, remove the spark plug.
7. Inspect the electrodes and center porcelain for deposits, corrosion, or carbon fouling. If the corrosion or deposits are heavy, replace the plug.

UNDER SEAT

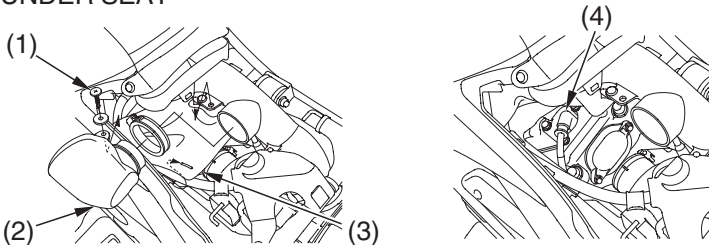

(1) screw

(2) resonance chamber

(3) rubber cover

(4) spark plug cap

8. Make sure that a 1.2 mm wire-type feeler gauge cannot be inserted between the spark plug gap (5). If the gauge fits in the gap, replace the plug with a new one.

(cont'd)

Spark Plug

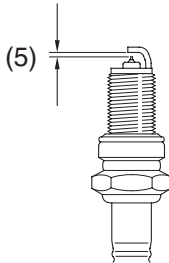

(5) spark plug gap

9. With the plug washer attached, thread the spark plug in by hand to prevent cross-threading.
10. Tighten the spark plug:
 - If the old plug is good:
 - 1/8 turn after it seats.
 - If installing a new plug, tighten it twice to prevent loosening:
 - a) First, tighten the plug:
 - NGK: 3/4 turn after it seats.
 - DENSO: 1/2 turn after it seats.
 - b) Then loosen the plug.
 - c) Next, tighten the plug again:
 - 1/8 turn after it seats.

NOTICE

An improperly tightened spark plug can damage the engine. If a plug is too loose, a piston may be damaged. If a plug is too tight, the threads may be damaged.

11. Reinstall the spark plug cap. Take care to avoid pinching any cables or wires.
12. Install the remaining parts in the reverse order of removal.

Valve Inspection

Refer to *Safety Precautions* on page 129.

Valve clearance should be:

intake: 0.006 in (0.15 mm)

exhaust: 0.013 in (0.33 mm)

Excessive clearance will cause noise. Insufficient clearance will cause loss of power and possibly damage the valves.

For those who are mechanically proficient and have the proper tools, instructions on adjusting valve clearances are given in the official Honda Service Manual. All others should have valves adjusted by your Honda dealer.

Spark Arrester

Refer to *Safety Precautions* on page 129.

The spark arrestor must be serviced every 100 operating hours to maintain its efficiency.

Regular servicing prevents carbon build up (which can diminish engine performance) and also complies with USDA regulations for regular maintenance to assure proper function. The spark arrestor prevents random sparks from the combustion process in your engine from reaching the environment.

1. Allow the engine and muffler to cool.
2. Remove the bolts (1), the spark arrestor (2) and the gasket (3) from the muffler (4).

REAR

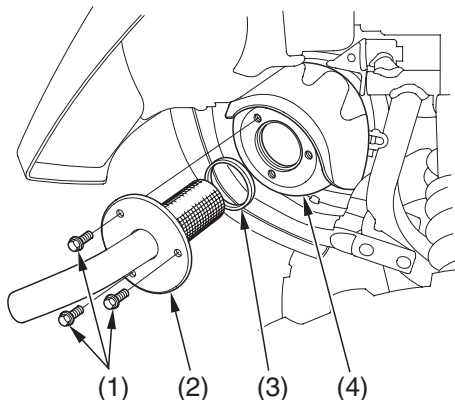

(1) bolts
(2) spark arrestor

(3) gasket
(4) muffler

Spark Arrester

- Use a brush to remove carbon deposits from the spark arrester screen (5). Be careful to avoid damaging the spark arrester screen. The spark arrester must be free of breaks and holes. Replace, if necessary. Check the gasket. Replace, if necessary.

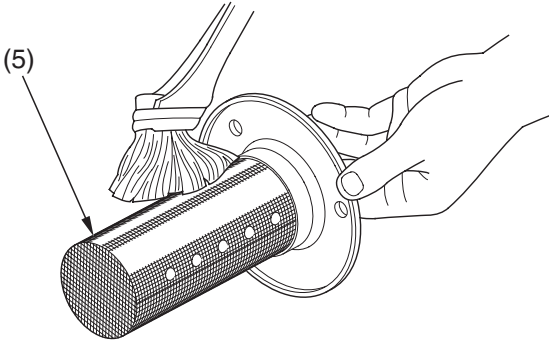

(5) spark arrester screen

- Install the spark arrester and the gasket in the muffler and tighten the bolts securely.

Brakes

The hydraulic disc brakes (front) and a single hydraulic/mechanical disc brake (rear) on your ATV dissipate the heat generated by the friction of the brake pads on the disc as the wheels are slowed.

As the front brake pads wear, brake fluid level will drop. A leak in the system will also cause the level to drop.

There are no adjustments to perform, but fluid level and pad wear must be inspected periodically. The system must be inspected frequently to ensure there are no fluid leaks.

If the brake lever or brake pedal freeplay does not feel within the normal range while riding, check the brake pads for wear (page 177). Worn pads should be replaced. If the pads are not worn beyond the recommended limit, there is probably air in the brake system. See your Honda dealer to have the air bled from the system.

Brake Fluid Recommendation

brake fluid	Honda DOT 4 Brake Fluid
-------------	-------------------------

The recommended brake fluid is Honda DOT 4 Brake Fluid, or any brake fluid of equal quality and performance. Use fresh brake fluid from a sealed container. Be sure to read the label before opening the sealed container. An opened container may be contaminated or may have absorbed moisture from the air.

Fluid Level Inspection

Refer to *Safety Precautions* on page 129.

Front Brake Fluid Level

RIGHT HANDLEBAR

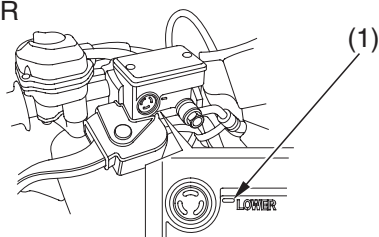

(1) LOWER level mark

If your inspection indicates a low fluid level, have your Honda dealer add the recommended fluid.

Do not add or replace brake fluid, except in an emergency. If you do add fluid, have your Honda dealer check the system as soon as possible.

NOTICE

Brake fluid can damage plastic and painted surfaces. Handle with care.

With the ATV in an upright position, check the fluid level.

It should be above the LOWER level mark (1). If the level is at or below the LOWER level mark, check the brake pads for wear (page 177).

Worn brake pads should be replaced. If the pads are not worn, have your brake system inspected for leaks.

(cont'd)

Brakes

Wipe up spills immediately. Avoid contact with skin or eyes. In case of contact, wash thoroughly and call a doctor immediately if it contacts your eyes.

Rear Brake Fluid Level

RIGHT SIDE

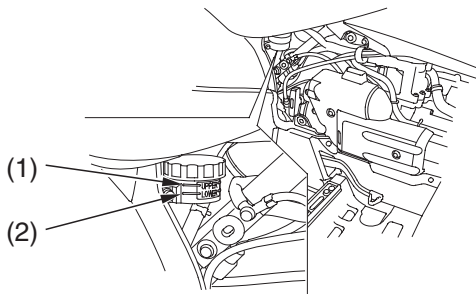

(1) UPPER level mark

(2) LOWER level mark

Remove the right side cover.

With the ATV in an upright position, check the fluid level.

It should be between the UPPER (1) and LOWER (2) level mark. If the level is at or below the LOWER level mark, check the brake pads for wear (page 178).

Worn brake pads should be replaced. If the pads are not worn, have your brake system inspected for leaks.

Other Inspections

- Make sure there are no fluid leaks.
- Check for deterioration or cracks in the hoses and fittings. If the hoses are worn or cracked, have them replaced by your Honda dealer.

Brake Pad Wear

Refer to *Safety Precautions* on page 129.

Brake pad wear will depend upon the severity of usage and riding conditions. The pads will wear faster in wet or muddy conditions. Inspect the pads visually during all regular service intervals to determine the pad wear.

FRONT

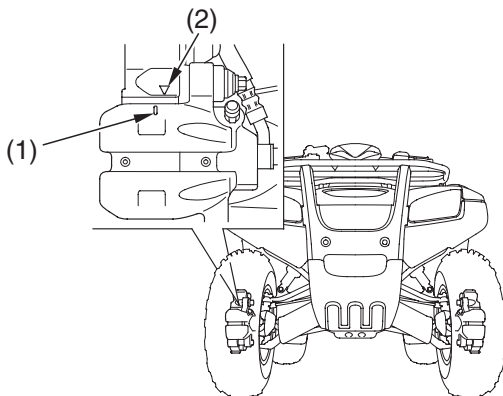

(1) wear indicator

(2) reference mark

Check the wear indicator (1). Remove the front wheels (page 220). If the wear indicator aligns with the reference mark (2), both pads must be replaced, see your Honda dealer for this replacement.

Always inspect both pads in both the right and left front brake calipers.

Brakes

REAR

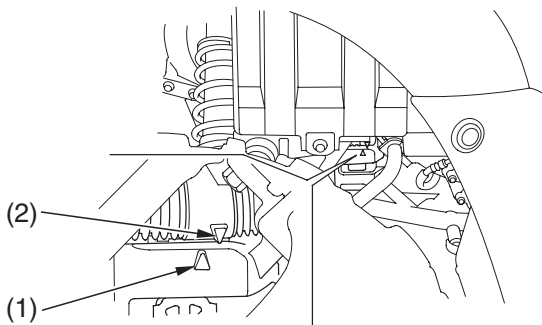

(1) wear indicator

(2) edge of reference mark

Check the wear indicator. If the wear indicator (1) aligns with the reference mark (2), replace both pads as a set, see your Honda dealer for this service.

Rear Brake Lever Freeplay

LEFT HANDLEBAR

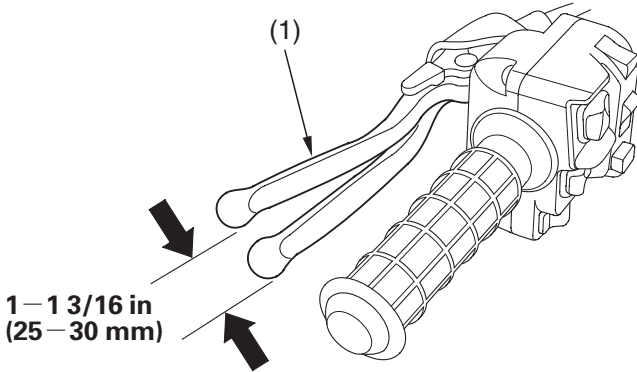

(1) rear brake lever/parking brake lever

Inspection

1. Depress the rear brake pedal several times.
2. Measure the distance the rear brake lever/parking brake lever (1) moves before the brake starts to take hold. Freeplay, measurement at the tip of the end of the brake lever, should be:
1 - 1 3/16 in (25 - 30 mm)
3. If necessary, adjust to the specified range.

Brakes

Adjustment

RIGHT REAR

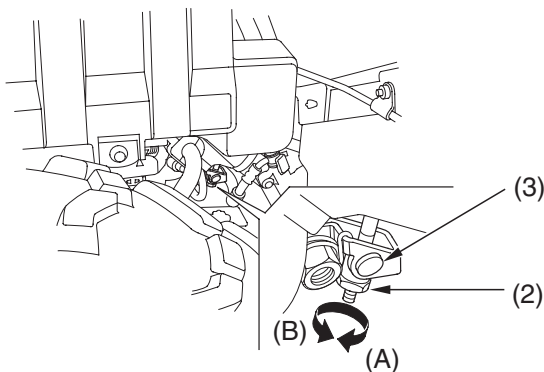

(2) brake lever adjusting nut

(3) brake arm pin

(A) increase freeplay

(B) decrease freeplay

Turn the brake lever adjusting nut (2), located on the brake operating rod at the brake caliper. Make sure the cutout on the adjusting nut is properly seated on the brake arm pin (3).

Other Inspections

- Check that the brake lever and brake pedal assemblies are positioned properly and the securing bolts are tight.
- Make sure that the brake cables, brake arm, spring, and fasteners are in good condition.

Brakelight Switch Adjustment

Refer to *Safety Precautions* on page 129.

Rear Brake Only:

Check the operation of the rear brakelight switch (1) at the right side behind the engine from time to time. The brakelight should turn on at 0.6 in (15 mm) of pedal stroke. Adjustment is done by turning the adjusting nut (2). Turn the nut in direction (A) if the switch operates too late and in direction (B) if the switch operates too soon.

RIGHT SIDE

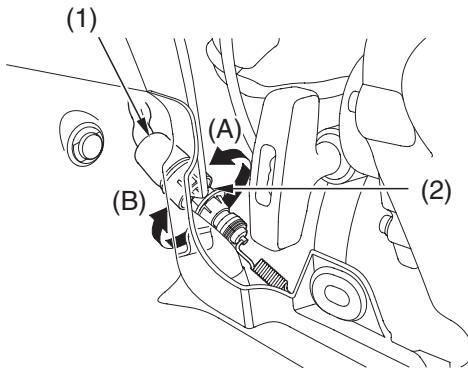

(1) brakelight switch

(2) adjusting nut

Tires

To safely operate your ATV, your tires must be the proper type and size, in good condition with adequate tread, and correctly inflated.

WARNING

Using tires that are excessively worn or improperly inflated can cause a crash in which you can be seriously hurt or killed.

Follow all instructions in this owner's manual regarding tire inflation and maintenance.

This ATV is equipped with low pressure tubeless tires. Although the tires are designed specifically for off-road use, they are not immune to punctures. Always select your riding area with care.

The following pages give detailed information on how and when to check your air pressure, how to inspect your tires for wear and damage, and our recommendations for tire repair and replacement.

Air Pressure

Refer to *Safety Precautions* on page 129.

Properly inflated tires provide the best combination of handling, tread life, and riding comfort. Generally, underinflated tires wear unevenly, adversely affect handling, and are more likely to fail from being overheated. Overinflated tires make your ATV ride harshly, are more prone to damage from surface hazards, and wear unevenly.

Make sure the valve stem caps are secure. If necessary, install a new cap.

Tires

Always check air pressure when your tires are “cold.” If you check air pressure when your tires are “warm” — even if your ATV has only been ridden for a few miles — the readings will be higher. If you let air out of warm tires to match the recommended cold tire pressures, the tires will be underinflated. Be sure to check tire pressure at the riding site, since changes in altitude can affect air pressure.

The recommended “cold” tire pressures are:

		FRONT	REAR
NO CARGO	RECOMMENDED PRESSURE	4.4 psi (30 kPa , 0.30 kgf/cm ²)	3.6 psi (25 kPa , 0.25 kgf/cm ²)
	MAXIMUM PRESSURE	5.0 psi (34 kPa , 0.34 kgf/cm ²)	4.0 psi (28 kPa , 0.28 kgf/cm ²)
	MINIMUM PRESSURE	3.8 psi (26 kPa , 0.26 kgf/cm ²)	3.2 psi (22 kPa , 0.22 kgf/cm ²)
WITH CARGO	RECOMMENDED PRESSURE	4.4 psi (30 kPa , 0.30 kgf/cm ²)	3.6 psi (25 kPa , 0.25 kgf/cm ²)

A manually operated tire pump should be used rather than the high pressure system found in service stations. This will minimize the possibility of tire damage from overinflation. If you use a high pressure system at a service station, add air in small amounts and check the pressure increase frequently to prevent possible tire damage from overinflation.

WARNING

Operating this ATV with improper tires, or with uneven tire pressure may cause loss of control, and you could be seriously injured or killed.

- Always use the size and type tires specified in this owner's manual for this vehicle.
- Always maintain proper tire pressure as described in this owner's manual.

Inspection

Refer to *Safety Precautions* on page 129.

Whenever you check the tire pressures, you should also look for:

- Bumps or bulges in the side of the tire or the tread. Replace any tire that has a bump or bulge.
- Cuts, slits, or cracks in the tires. Replace the tire if you can see fabric or cord.
- Nails or other foreign objects embedded in the side of the tire or tread.
- Excessive tread wear.

Tires

Also, if you hit a pothole or other hard object while riding, stop as soon as you safely can and carefully inspect the tires for damage.

Tread Wear

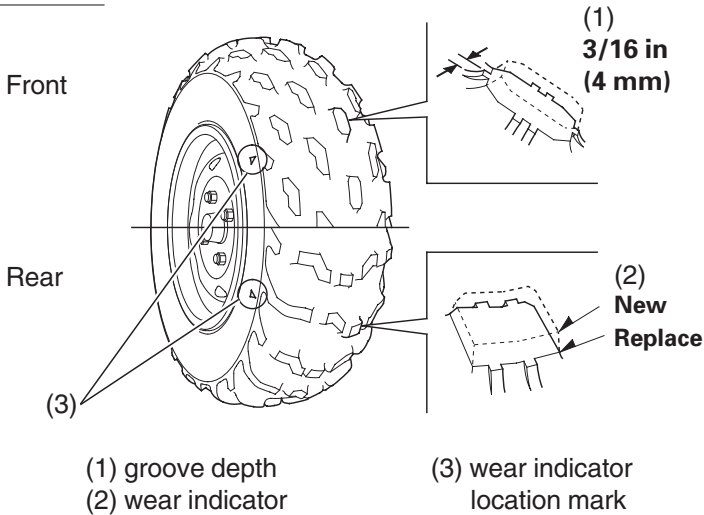

To check the condition of a tire tread, measure the groove depth (1) in the center of the tire, or check the wear indicator (2).

For best performance, you should replace a tire before the tread depth at the center reaches the following limits:

front	3/16 in (4 mm)
rear	3/16 in (4 mm)

Tire Repair

Refer to *Safety Precautions* on page 129.

A tire that is repaired, either temporarily or permanently, will have lower speed and performance limits than a new or undamaged tire.

A temporary repair can sometimes be made in an emergency situation. However, since a temporary repair may not hold, you must ride very slowly, preferably without any cargo, and have the tire replaced or permanently repaired as soon as possible. (For more information on temporary repairs, see *If You Have a Flat Tire*, page 219 .)

A permanent repair, such as an internal plug patch, can be made if a tire has only a small puncture in the tread area. However you may not be able to safely carry as much weight. If you choose to have a tire repaired, be sure the repair work is performed by a professional.

If you have a tire professionally repaired at a non-Honda facility, we recommend that you have the work checked by your Honda dealer.

Tires

Tire Replacement

Refer to *Safety Precautions* on page 129.

The tires that came on your ATV were designed to match the performance capabilities of your ATV and provide the best combination of handling, braking, and comfort.

It is best to replace all four tires, however if that is not possible, you must replace the tires in pairs (front or rear) with tires of the same size and type as the originals. Never replace just one tire.

WARNING

Installing improper tires on your ATV can affect handling and stability. This can cause a crash in which you can be seriously hurt or killed.

Always use the size and type of tires recommended in this owner's manual.

The recommended tires for your ATV are:

front	AT25 × 8R12 ★★	DUNLOP KT511
rear	AT25 × 10R12 ★★	DUNLOP KT515

When you replace a tire, remember:

Have the tire replaced by your Honda dealer if possible.

If you have a tire professionally replaced at a non-Honda facility, we recommended that you have the work checked by your Honda dealer.

Engine Guard & Skid Plate

Refer to *Safety Precautions* on page 129.

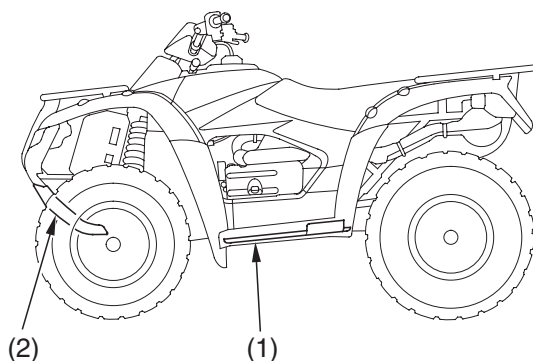

(1) engine guard

(2) skid plate

The engine guard (1) protects the engine crankcase.

The skid plate (2) protects the frame. Check the guard and plate for cracks, damage or looseness at intervals shown in the Maintenance Schedule.

Have the engine guard and skid plate replaced if they are cracked or damaged. If the guard and plate bolts are loose, tighten them securely.

Driveshaft Boots

Refer to *Safety Precautions* on page 129.

FRONT

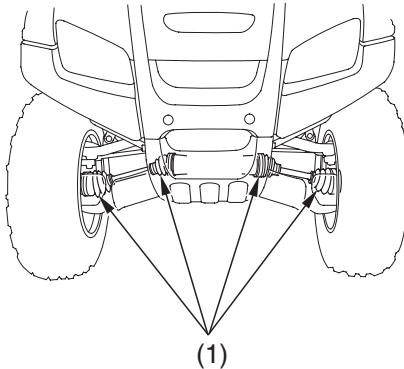

REAR

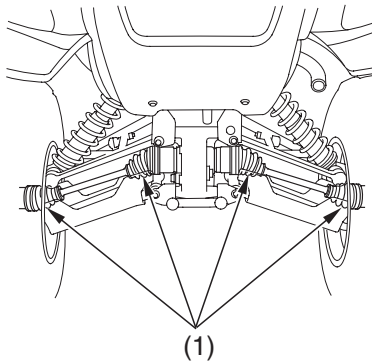

(1) driveshaft boots

Check the rubber driveshaft boots (1) for damage or leaking grease. If necessary, have your Honda dealer replace them.

Battery

Your ATV has a maintenance-free type battery. You do not have to check the battery electrolyte level or add distilled water as you would with a conventional-type battery.

NOTICE

Your battery is a maintenance-free type and can be permanently damaged if the cap strip is removed.

Electrical accessories use current from the battery — even when the ignition is OFF. Limited operation also allows the battery to discharge. If you have electrical accessories on your ATV — or do not ride frequently, we recommend that you charge the battery frequently (see *Battery Charging*, page 195).

If you do not expect to ride your ATV for at least two weeks, we recommend you remove the battery — or at least disconnect the battery cables (negative cable first).

If you plan to store your ATV, see *Battery Storage*, page 192 .

If your battery seems weak and/or is leaking electrolyte (causing slow starting or other electrical problems), see your Honda dealer.

WARNING: Battery posts, terminals and related accessories contain lead and lead compounds. **Wash your hands after handling.**

Battery

Battery Storage

Refer to *Safety Precautions* on page 129.

If you plan to store your ATV, we recommend you remove the battery and store it where it can be charged at least every 30 days to maintain its service life.

If you do not remove the battery, we recommend disconnecting the battery cables (negative cable first).

You will get the best storage results from removing the battery and slow (trickle) charging it every 30 days (see *Battery Charging*, page 195).

Before you remove the battery, be sure to read all the information that follows, as well as the information on the battery label.

WARNING

The battery gives off explosive hydrogen gas during normal operation.

A spark or flame can cause the battery to explode with enough force to kill or seriously hurt you.

Wear protective clothing and a face shield, or have a skilled mechanic do the battery maintenance.

Battery

The battery is located under the rear fender.

UNDER SEAT

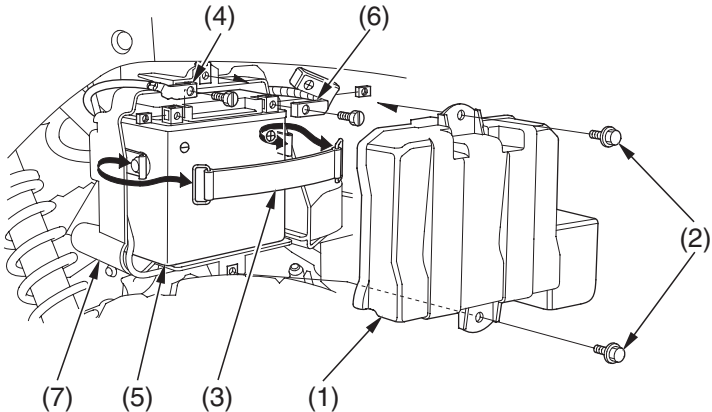

(1) battery cover

(2) bolts

(3) rubber band

(4) negative (-) terminal lead

(5) battery

(6) positive (+) terminal lead

(7) battery box

Removal

1. Make sure the ignition switch is OFF (\bigcirc).
2. Remove the battery cover (1) by removing the bolts (2).
3. Release the rings and remove the rubber band (3).
4. Disconnect the negative (-) terminal lead (4) from the battery (5) first, then disconnect the positive (+) terminal lead (6).

(cont'd)

Battery

5. Remove the battery from battery box (7).
6. Charge the battery (see following section), unless you have been riding regularly.
7. Store your battery in an easy-to-reach location off the floor, in an area protected from freezing temperature and direct sunlight.
8. Clean the battery box after removing the battery for storage. Dry the battery box and, if paint is missing, re-paint the area.
9. Slow charge the battery (see following section) once every 30 days.

Installation

1. Reinstall in the reverse order of removal.
Be sure to connect the positive (+) terminal first, then the negative (-) terminal.
2. Check all bolts and other fasteners are secure.

Battery Charging

Refer to *Safety Precautions* on page 129.

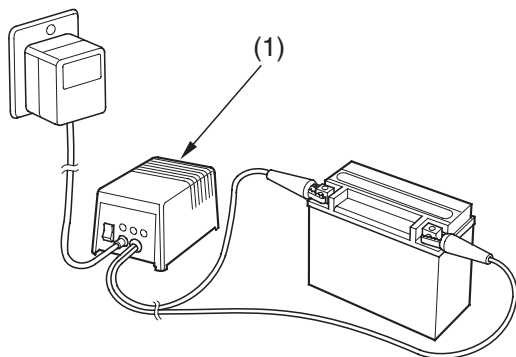

(1) “trickle” charger

Be sure to read the information that came with your battery charger and follow the instructions on the battery. Improper charging may damage the battery.

We recommend using a “trickle” charger (1) for home charging. These units can be left connected for long periods without risking damage to the battery. However, do not intentionally leave the charger connected longer than the time period recommended in the charger’s instructions.

Avoid using an automotive-type battery charger. An automotive charger can overheat an ATV battery and cause premature damage.

Appearance Care

Frequent cleaning and polishing will keep your Honda looking newer longer.

Frequent cleaning also identifies you as an owner who values his ATV. A clean ATV is also easier to inspect and service.

General Recommendations

Refer to *Safety Precautions* on page 129.

- To clean your ATV, you may use:
 - water
 - a mild, neutral detergent and water
 - a mild spray and wipe cleaner/polisher
 - a mild spray and rinse cleaner/degreaser and water
- Avoid products that contain harsh detergents or chemical solvents that could damage the metal, paint, and plastic on your ATV.
- If your ATV is still warm from recent operation, give the engine and exhaust system time to cool off.
- Park in a shady area. Washing your ATV in bright sunlight may cause the finish to fade because water droplets intensify the sun's brightness.
- Spotting is also more likely because surface water can dry before you have time to wipe it off.
- Clean your ATV regularly to protect surface finishes.
- We recommend the use of a garden hose to wash your ATV. High pressure washers (like those at coin-operated car washers) can damage certain parts of your ATV.

NOTICE

High pressure water (or air) can damage certain parts of your ATV.

- After cleaning, inspect for damage, wear, and leaks (fuel, oil, coolant and brake fluid).

Appearance Care

Washing Your ATV with a Mild Detergent

Refer to *Safety Precautions* on page 129.

1. Rinse your ATV thoroughly with cool water to remove loose dirt.
 2. Fill a bucket with cool water. Mix in a mild, neutral detergent, such as dish washing liquid or a product made especially for washing motorcycles or automobiles.
 3. Wash your ATV with a sponge or soft towel. As you wash, check for heavy grime. If necessary, use a mild cleaner/degreaser to remove the grime.
 4. After washing, rinse your ATV thoroughly with plenty of clean water to remove any residue. Detergent residue can corrode alloy parts.
 5. Dry your ATV with a chamois or a soft towel. Leaving water on the surface to air dry can cause dulling and water spots. As you dry, inspect for chips and scratches.
 6. Start the engine and let it idle for several minutes. The engine heat will help dry moist areas.
 7. As a precaution, ride your ATV at a slow speed and apply the brakes several times. This will help dry the brakes and restore normal braking performance.
- If the inside of the headlight lens appears clouded immediately after washing, it should clear after a few minutes of riding.

Appearance Care

Spray Cleaning Your ATV

Refer to *Safety Precautions* on page 129.

Avoid using spray cleaner products on the tires or suspension components.

Suggestions for using spray cleaner(s) follow:

ATV condition	Recommended Cleaning
Dust and fingerprint smudges.	Apply a spray cleaner/polish and wipe paint, chrome, glass, and clear plastic.
Light road grimes.	Spray any difficult-to-reach or very dirty areas with a spray cleaner/degreaser. Rinse and dry. Apply a spray cleaner/polish and wipe with a non-abrasive cloth.
Heavy grime. Oil leaks. Brake dust.	Use a spray cleaner/degreaser. If necessary, rub with a sponge. Rinse and dry. Apply a spray cleaner/polish and wipe with a non-abrasive cloth.
Dull, corroded chrome or aluminum.	Apply a high quality chrome/aluminum polish and wipe with a non-abrasive cloth.

Appearance Care

Aluminum Wheel Maintenance

Refer to *Safety Precautions* on page 129.

Aluminum may corrode from contact with dirt, mud, or road salt. Clean the wheels after riding through any of these substances. Use a wet sponge and mild detergent. Avoid stiff brushes, steel wool, or cleaners containing abrasives or chemical compounds.

After washing, rinse with plenty of water and dry with a clean cloth. Then apply a mild, commercially-available spray cleaner/polish or wax.

For stained or dull-looking wheels, use a quality chrome/aluminum polish to restore the finish.

Appearance Care

Finishing Touches

Refer to *Safety Precautions* on page 129.

After washing your ATV, consider using a commercially-available spray cleaner/polish or quality liquid or paste wax to finish the job. Use only a non-abrasive polish or wax made specifically for motorcycles or automobiles. Apply the polish or wax according to the instructions on the container.

If a surface on your ATV is chipped or scratched, your Honda dealer has touch-up paint to match your ATV's color. Be sure to use your ATV's color code (page 235) when you buy touch-up paint.

If the frame has a chip that exposes the metal, first apply primer (to prevent corrosion) and then apply the touch-up paint. Several thin layers of touch-up paint are better than one thick coat.

Here's helpful advice on how to prepare for an off-road adventure, how to transport and store your Honda, and how to be an environmentally responsible ATV owner.

Preparing for a Ride	202
What to Take to The Riding Area	202
What to Take on The Trail	203
Transporting Your Honda	204
Storing Your Honda	206
You & the Environment	210

Preparing for a Ride

A safe and enjoyable ride begins with good planning and preparation. Always ride with at least one other person in case you have trouble, and let someone know where you're going and when you expect to return.

Before riding in an unfamiliar area, find out in advance if you need special permits, get maps so you can study the terrain, and talk to other riders who know the area. The Forest Service and the Bureau of Land Management (USA only), the Ministry of Natural Resources (Canada only), riding clubs, and off-road magazines are good sources of information.

What to Take to the Riding Area

Along with your ATV and riding gear, you should take along some tools and supplies in case you have a problem. For some of the difficulties you might encounter, see *Taking Care of the Unexpected*, which begins on page 211.

We recommend that you always take water, food, a first aid kit, and your owner's manual. Other items you should consider loading on your truck or trailer include:

- a tool kit
- tire repair supplies and tools, and tires
- extra parts, control levers, cables, and spark plugs
- wire, duct tape, and rope
- extra gasoline

For safety, all refueling should be done at a gas station on the way to the riding area or at your base camp.

Preparing for a Ride

What to Take on the Trail

What you take with you during a ride depends on the kind of terrain, how long you expect to ride, how far you might go from your base camp or help, and how experienced you or your companions are in making repairs.

If you decide to take some tools, spare parts, or other supplies on the trail, be sure you can carry them safely and know how to use them. Also, be sure to follow the loading guidelines and weight limit (page 84).

Transporting Your Honda

Do not tow your ATV behind a car or other vehicle.

When you transport your ATV, we recommend that you carry the vehicle in its normal operating position (on all four wheels). Do not incline the vehicle upright on its rear end. This can damage the vehicle, and leaking gasoline could be a hazard.

Follow these procedures:

1. Set the parking brake.

Transporting Your Honda

2. Secure the vehicle with “tie-down straps” in the areas shown.
 - Suitable “tie-down straps” are available from your Honda dealer.
 - Ordinary rope is not recommended because it can stretch under load.
 - Using “tie-down straps” in any other areas can damage your ATV.
3. Rock the vehicle back and forth to make sure the “tie-down straps” are tight and the vehicle is secure.

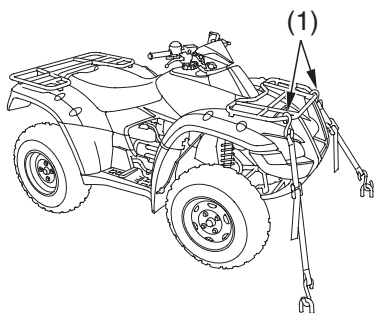

(1) front cargo rack

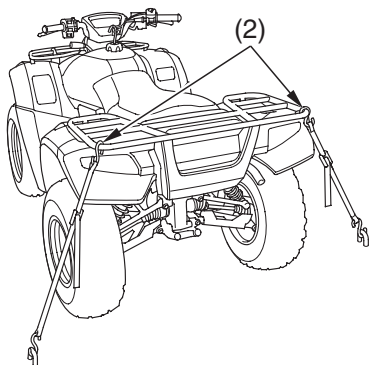

(2) rear cargo rack

Storing Your Honda

If you won't be riding for an extended period, such as during the winter, thoroughly inspect your ATV and correct any problem before storing it. That way, needed repairs won't be forgotten and it will be easier to get your ATV running again.

For more information about storage, refer to the *Honda Motorcycle Winter Storage Guide*, available from your Honda dealer (USA only).

We suggest you perform the following procedures to keep your ATV in top condition. These storage procedures will reduce the deterioration that can occur during storage.

Storing Your Honda

Preparation for Storage

Refer to *Safety Precautions* on page 129.

This procedure requires a means for draining and disposing of drained fuel (page 210).

1. Change the engine oil and filter (page 149).
2. Make sure the cooling system is filled with a 50/50% antifreeze solution (page 156).
3. Fill the fuel tank. Make sure the fuel fill cap is properly installed.
4. To prevent rusting in the cylinders, perform the following:
 - Remove the spark plug cap from the spark plug.
 - Remove the spark plug.
Do not connect the spark plug to the spark plug cap.
 - Pour a tablespoon (15 – 20 cc) of clean engine oil into cylinder and cover the spark plug hole with a piece of cloth.
 - With the engine stop switch in the RUN (\odot) position, press the start button several times to crank the engine and distribute the oil.
 - Reinstall the spark plug and spark plug cap.

(cont'd)

Storing Your Honda

5. Remove the battery and charge it fully. Store it in an area protected from freezing temperatures and direct sunlight. Slow charge the battery (page 195) once a month.

WARNING

The battery gives off explosive hydrogen gas during normal operation.

A spark or flame can cause the battery to explode with enough force to kill or seriously hurt you.

Wear protective clothing and a face shield, or have a skilled mechanic do the battery maintenance.

6. Wash and dry your ATV. Wax all painted surfaces.
7. Inflate the tires to their recommended pressures (page 183).
8. Store your ATV in an unheated area, free of dampness, away from sunlight, with a minimum of daily temperature variation.
9. Place your ATV on blocks to lift all tires off the floor.
10. Cover your ATV with a porous material. Avoid using plastic or similar non-breathing, coated materials that restrict air flow and allow heat and moisture to accumulate.

Storing Your Honda

Removal from Storage

Refer to *Safety Precautions* on page 129.

1. Uncover and clean your ATV.
2. If your ATV has been stored for more than four months — change the engine oil (page 149).
3. If your ATV has been stored for more than two months — ask your Honda dealer to drain and replace the fuel.
4. Charge the battery (page 195) as required. Install the battery.
5. Perform a pre-ride inspection (page 79), then test-ride your ATV at low speeds.

You & the Environment

Owning and riding an ATV can be enjoyable, but you must do your part to protect nature. When you show respect for the land, wildlife, and other people, you also help preserve the sport of off-road riding.

Following are tips on how you can be an environmentally-responsible ATV owner.

- **Tread Lightly.** Stay on existing roads and trails, avoid surfaces that are easily damaged, and ride only in areas approved for off-road vehicles.
- **Keep the Noise Down.** Loud vehicles can be offensive. Ride as quietly as possible, don't remove your spark arrester, and don't modify the muffler or any other part of your air intake and exhaust systems. Such modifications not only increase noise, they also reduce engine performance and may be illegal.
- **Choose Sensible Cleaners.** Use a biodegradable detergent when you wash your ATV. Avoid aerosol spray cleaners that contain chlorofluorocarbons (CFCs) which damage the atmosphere's protective ozone layer. Don't throw cleaning solvents away; see the following guidelines for proper disposal.
- **Recycle Wastes.** It's illegal and thoughtless to put used engine oil in the trash, down a drain, or on the ground. Used oil, gasoline, and cleaning solvents contain poisons that can hurt refuse workers and contaminate our drinking water, lakes, rivers, and oceans. Before changing your oil, make sure you have the proper containers. Put oil and other toxic wastes in separate sealed containers and take them to a recycling center. Call your local or state office of public works or environmental services to find a recycling center in your area, and to get instructions on how to dispose of non-recyclable wastes.

Taking Care of the Unexpected

With all the challenges you can encounter off-road, there's a chance that sometime something may go wrong. This section gives practical advice to help you deal with a wide range of problems. Take time to read this section before you ride. Also review the tips in *Preparing for a Ride* (page 202).

General Guidelines.....	212
If Your Engine Quits or Won't Start.....	215
If the Transmission Is Not Functioning Properly	217
If You Have a Flat Tire	219
If the High Oil/Coolant Temperature Indicator Lights	222
If a Fuse Blows	224
If You Crash.....	228
If You Lose Your Key	229
If the Battery Is Low (or Dead).....	230
If a Component Fails.....	231

Taking Care of the Unexpected

General Guidelines

Keeping your ATV well-maintained is the best way to reduce the possibility of having a problem while riding. However, problems can arise even with well-maintained machines.

Remember to take along your owner's manual, the tool kit that came with your ATV, and any other items (such as tire repair supplies and additional tools) that might help you solve a problem on your own.

If something goes wrong during a ride, the first thing to do is stop as soon as you safely can. Do not continue riding if you have a flat tire, or you hear an unusual noise, or your ATV just doesn't feel right. If you continue riding, you could cause more damage and endanger your own safety.

After a stop, take time to assess the situation. Carefully inspect your ATV to identify the problem, then consider your options before you decide what to do.

If a problem is relatively minor and you have the tools, supplies, and skills to make a permanent repair, you may be able to fix it on the trail and continue riding. Or, you may be able to make a temporary repair that allows you to slowly ride back to your base where you can make a permanent repair or get help.

When a problem is more serious—or you don't have the tools, supplies, experience, or time to deal with it—you need to choose the safest way to get yourself and your ATV back to base. For example, if you are close enough, you (or you and another person) might be able to push it back.

Taking Care of the Unexpected

Should you ever have a problem while riding, please follow these guidelines:

- Always put personal safety first.
- Take time to assess the situation and your options before deciding what to do.
- If the problem is relatively minor and you have the tools, supplies, and skills to make a temporary repair, be sure to have permanent repairs made as soon as possible.
- Do not continue riding if you are hurt or your ATV is not in safe riding condition.

Additional recommendations for specific problems follow.

If Your Engine Quits or Won't Start

Proper operation and maintenance can prevent starting and engine performance problems. In many cases, the cause of the problem may be a simple operational oversight.

If you have a problem starting the engine—or experience poor engine performance—the following information may help you. If you can't correct the problem, see your Honda dealer.

If your ATV won't start, listen as you press the start button. If you don't hear the starter motor turning, refer to the *Starter motor doesn't operate* symptom. If you can hear the starter motor working normally, refer to the *Starter motor works, but the engine won't start* symptom.

If Your Engine Quits or Won't Start

SYMPTOM: Starter motor doesn't operate.	
POSSIBLE CAUSE	WHAT TO DO
ignition switch OFF	Turn the ignition switch ON.
engine stop switch OFF	Turn the engine stop switch to RUN.
transmission not in neutral	Shift into neutral.
blown fuse	Replace with a new fuse of the same rating (page 224).
battery lead loose	Tighten the battery lead.
low (or dead) battery	Charge the battery (page 195). If charging doesn't help, see your Honda dealer.
faulty starter motor	If all possible causes are negative, the starter motor may be faulty. See your Honda dealer.

SYMPTOM: Starter motor works, but the engine won't start.	
POSSIBLE CAUSE	WHAT TO DO
out of fuel	Fill the fuel tank.
flooded engine	See <i>Flooded Engine</i> (page 98).
loose or unconnected spark plug cap	Install the spark plug cap securely. If the engine still won't start, see your Honda dealer.
loose battery cables	Tighten the battery terminal bolts.
weak battery	Charge the battery (page 195). If charging doesn't help, see your Honda dealer.

If Your Engine Quits or Won't Start

SYMPTOM: Engine starts, but runs poorly.	
POSSIBLE CAUSE	WHAT TO DO
high oil/coolant temperature	Check the high oil/coolant temperature indicator. Refer to <i>If the High Oil/Coolant Temperature Indicator Lights</i> , page 222 .
runs erratically, misfires	See your Honda dealer.
blubbers (rich fuel mixture)	See your Honda dealer.
sooty exhaust (rich fuel mixture)	See your Honda dealer.
detonates or pings under load	If applicable, switch to the recommended octane gasoline (page 141) or change your brand of gasoline. If the problem persists, see your Honda dealer.
afterfires (backfires)	See your Honda dealer.
pre-ignition (runs on after ignition switched OFF)	See your Honda dealer.

If the Transmission Is Not Functioning Properly

Manual Shift (ESP) Mode:

If one or both shift switches do not function, stop riding your ATV in the ESP mode. Switch to riding in the AUTO (automatic shift) mode. Have your ATV inspected and repaired by your Honda dealer.

Automatic Shift (Auto) Mode:

When the automatic transmission is not shifting properly, the gear position indicator will show “- -” and blink.

See your Honda dealer to check and restore the automatic transmission.

If the gear position indicator shows “- -” and blinks while riding, perform the following:

1. Stop the ATV.
2. Turn the ignition switch to the “OFF” (○) position.
3. After the engine stops, turn the ignition switch to the “ON” (|) position.
4. Check the gear position indicator.

When the “- -” is blinking on the gear position indicator:

Restart the engine; drive the vehicle to a location where it can be loaded and transported to a Honda dealer.

When the display on the gear position indicator returns to normal:

You may drive the vehicle as usual after restarting the engine. However, we urge you to have your ATV inspected by your Honda dealer.

(cont'd)

If the Transmission Is Not Functioning Properly

Although “- -” is not blinking in the gear position indicator, the vehicle does not move:

If your ATV won't move, it is possible the transmission is locked. Use the following procedure to unlock the transmission.

1. Shift the shift lever in neutral (N) position.
2. Apply the parking brake.
3. Turn the ignition switch to the “OFF” (O) position.
4. Loosen the screw (1) and release the lock plate (2).
5. Turn the emergency valve (3) all the way in. With the engine running, your ATV will move forward slowly at idle.
6. See your Honda dealer as soon as possible.

LEFT SIDE

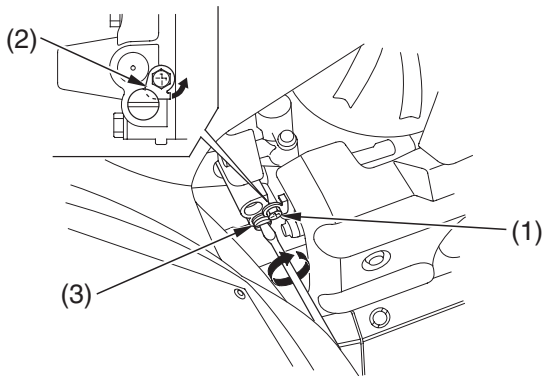

(1) screw
(2) lock plate

(3) emergency valve

If You Have a Flat Tire

How you handle a flat tire on the trail depends on how serious the tire damage is, and what tools and supplies you have with you.

If you have a slow leak or a minor puncture, use the plug method to make a temporary repair. (The plug method is applied from the outside of the tire and is the same as that for conventional tubeless tires.)

A plug-type repair kit, available at most auto parts stores or service stations, provides a plug, an installation tool, tire cement, and an instruction sheet. Follow the instructions provided with the repair kit to make a temporary repair.

As soon as possible, have the tire permanently repaired by your Honda dealer. Any tire that cannot be repaired should be replaced.

Whenever the ATV is to be operated far from service facilities or available transportation, we recommend that you carry a tire pump and a repair kit with the vehicle.

If the leak is more serious, or a temporary repair doesn't hold, the tire must be replaced. The tire will also need to be replaced if it is damaged (page 186). Replacing a tire involves removing and re-installing the wheel (page 220).

If you are unable to repair a flat tire on the trail, you will need to send for help. We strongly recommend that you do not try to ride with a flat tire. The ATV will be hard to handle, and if the tire comes off the rim, it may lock up the wheel and cause you to crash.

If You Have a Flat Tire

Emergency Wheel Removal/Installation

Refer to *Safety Precautions* on page 129.

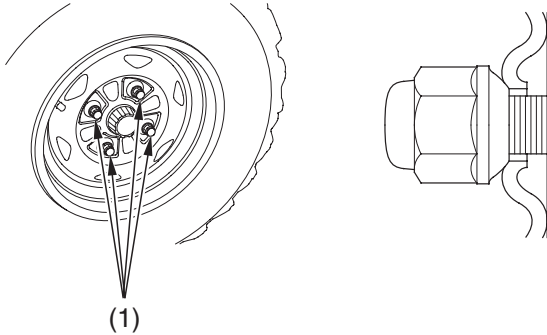

(1) wheel nuts

Removal

1. Park your ATV on a firm, level surface.
2. Raise the front (or rear) wheels off the ground and place a support block under the vehicle.
3. Remove the wheel nuts (1).
4. Remove the wheel.
 - Avoid getting grease, oil, or dirt on the disc or pad surfaces when removing and installing each wheel. Any contamination can cause poor brake performance or rapid pad wear after reassembly.

If You Have a Flat Tire

Installation

1. Position the wheel.
2. Position the wheel nuts.
3. Tighten the wheel nuts in a crisscross (rather than a circular) pattern to the specified torque:
47 lbf·ft (64 N·m , 6.5 kgf·m)

If a torque wrench was not used for installation, see your Honda dealer as soon as possible to verify proper assembly. Improper assembly may lead to loss of braking capability.

If the High Oil/Coolant Temperature Indicator Lights

Normally, the high oil/coolant temperature indicator will only light momentarily when you turn the ignition ON (I). Occasionally, it may flicker at or near idling speed.

High oil/coolant temperature may be caused by restriction of air flow to the radiator (such as mud caked on the radiator), extended idling, an oil leak, a coolant leak, a low oil level, a low coolant level, or extended operation under adverse conditions.

If the indicator comes on while you're riding, don't ignore it. Pull safely to a stop. Stop the engine as soon as it's safe to do so, and let it cool.

NOTICE

Continuing to ride with low oil pressure or an overheated engine can cause serious engine damage.

- A steaming engine indicates a coolant leak. Shut the engine off and wait until the steaming stops. Look for a leak, but don't touch the engine or radiator system. Let everything cool off first.
- Check for any restriction of air flow to the radiator.
- If there's no obvious problem, leave the engine on so the fan and coolant circulating system can continue working. Monitor the high coolant temperature indicator. The indicator may turn off after a brief stop with no load on the engine.
- Check the radiator fan.

If the fan is not working, turn the engine off. Open the fuse box (page 224) and check the radiator fan fuse. If the fuse is blown, replace it with the proper (same rating) spare fuse. Start the engine. If the high coolant temperature indicator comes on and stays on, turn the engine off.

If the radiator fan is working, visually check the coolant level in the reserve tank, located under the rear fender. It isn't necessary to touch the radiator system.

If the High Oil/Coolant Temperature Indicator Lights

- If the reserve tank is low or empty, don't ride without adding coolant (page 157). After adding coolant, turn the engine on and check the high coolant temperature indicator.
If the indicator doesn't turn off, do not ride. The engine needs repair. Transport your ATV to a Honda dealer (page 204).
If the temperature drops to normal, check the coolant level. If it has gone down, add more coolant.
- Check for an oil leak.
- Check the oil level. If necessary, add the recommended oil (page 144) to the upper level mark. If you must leave your ATV to get oil, secure it as much as possible.
- Start the engine, and check that the high oil/coolant temperature indicator goes off.

If you are able to resume riding, continue to monitor the high coolant temperature indicator frequently.

If there is an oil leak — do not ride the ATV until the leak is repaired by Honda dealer (page 204).

If there's a mild coolant leak, you can ride for awhile, carefully watching the indicator. Be prepared to stop and add more coolant or water. If the leak is bad, transport your ATV to a Honda dealer (page 204).

If a Fuse Blows

All of the electrical circuits on your ATV have fuses to protect them from damage caused by excess current flow (short circuit or overload).

If something electrical on your ATV stops working, the first thing you should check for is a blown fuse (1).

Check all the fuses before looking elsewhere for another possible cause of the problem. Replace any blown fuses and check component operation.

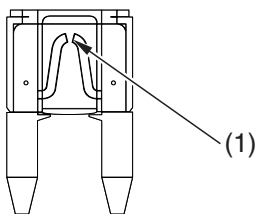

(1) blown fuse

The main fuse and the circuit fuses are located in the battery compartment.

Recommended Fuses

main fuse 1	30 A
main fuse 2	30 A
other fuses	15 A × 1, 10 A × 4

If a Fuse Blows

Main Fuse Access

1. To prevent an accidental short circuit, turn the ignition switch OFF (○) before checking or replacing the fuses.
2. Remove the seat (page 140).
3. To access the main fuse (2) (3), remove the fuse box cover (4).

UNDER SEAT

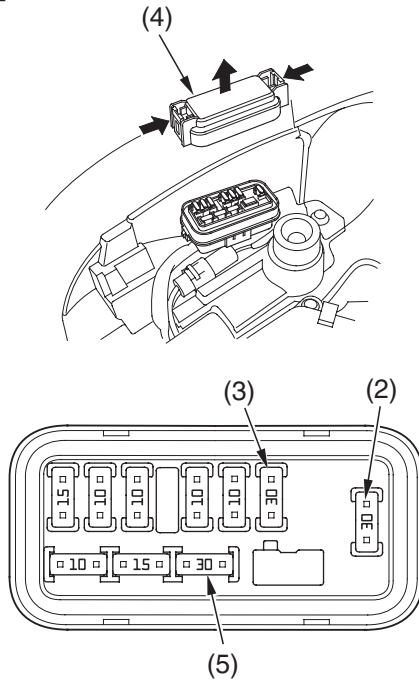

- (2) main fuse 1
(3) main fuse 2

- (4) fuse box cover
(5) spare main fuse

4. Pull the main fuse out.
If it is blown, install the spare main fuse (5).

(cont'd)

If a Fuse Blows

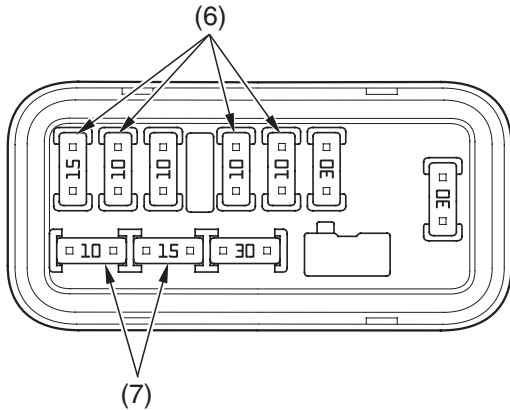

(6) circuit fuses

(7) spare fuses

Circuit Fuse Access

5. To check or replace a circuit fuse (6), pull the old fuse out of its retaining clips.

If the fuse is blown, replace it with a spare fuse (7) of the same rating or lower.

If you do not have a replacement fuse with the proper rating for the circuit, install one with a lower rating.

NOTICE

Replacing a fuse with one that has a higher rating greatly increases the chance of damage to the electrical system.

6. Install the seat.

7. Install the fuse box cover.

If a Fuse Blows

If you do not have a spare fuse and you cannot ride the ATV without fixing the problem, take a fuse of the same rating or a lower rating from one of the other circuits that you can do without temporarily.

If you replace a blown fuse with a spare fuse that has a lower rating, replace the fuse with the correct rating as soon as you can. Also remember to replace any spare fuses that were installed.

If the replacement fuse of the same rating burns out in a short time, there is probably a serious electrical problem on your ATV. Leave the blown fuse in that circuit and have your ATV checked by your Honda dealer.

If You Crash

Personal safety is your first priority after an accident. If you or anyone else has been injured, take time to assess the severity of the injuries and whether it is safe to continue riding. If you cannot ride safely, send someone for help. Do not ride if you will risk further injury.

If you decide you are capable of riding safely, carefully inspect your ATV for damage and determine if it is safe to ride. Check the tightness of critical nuts and bolts securing such parts as the handlebar, control levers, brakes, and wheels.

If there is minor damage, or you are unsure about possible damage but decide to try riding the ATV back to your base, ride slowly and cautiously.

Sometimes, crash damage is hidden or not immediately apparent. When you get home, thoroughly check your ATV and correct any problems you find. Also, be sure to have your Honda dealer check the frame and suspension after any serious crash.

If You Lose Your Key

Be sure to record your key number (1) in the Quick Reference section at the rear of the manual. You'll need this number to have a duplicate key made.

If you lose your key and aren't carrying a duplicate, either get your spare or have one made. If you don't know your key number, call the dealer you purchased your Honda from. They may have it listed in their records. If they don't, transport your ATV to them or the nearest Honda dealer. The dealer will probably have to remove the ignition switch assembly to find the key number so they can make a key for you.

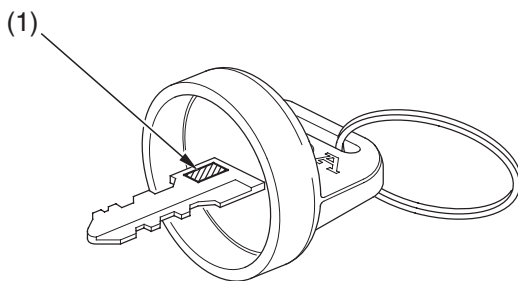

(1) key number

If the Battery Is Low (or Dead)

Your ATV will operate even if the battery is low (or dead), as long as the engine is running. If the engine is not running, it may be started using the recoil starter.

1. Shift the shift lever in neutral (N) position.
2. Apply the parking brake.
3. Turn the ignition switch to the “ON” (I) position.
4. Use the recoil starter (page 101) to start the engine.

Jump starting is not recommended, especially if you use an automobile battery. The greater amperage of an automobile battery when the car engine is running can damage your ATV’s electrical system.

Bump starting is also not recommended.

If you can’t charge the battery or it appears unable to hold a charge, contact your Honda dealer.

If a Component Fails

The brake levers or pedal, control cables, and other components can be damaged as you ride in dense brush or over rocky terrain. Making a trailside repair depends on how serious the damage is and what tools and supplies you have with you.

- If any component of the brake system is damaged, you may be able to ride carefully back to your base using the other brake components for slowing or stopping.
- If you damage a throttle cable or other critical component, your ATV may be unsafe to ride. Carefully assess the damage and make any repairs that you can. But if there is any doubt, it's best to be conservative and safe.

Technical Information

This section contains dimensions, capacities, and other technical data, plus information on government requirements and how to break-in your ATV.

Vehicle Identification.....	234
Specifications	236
Break-in Guidelines	240
Emission Control Systems.....	241
Oxygenated Fuels.....	245

Vehicle Identification

Serial Numbers

The VIN and engine serial numbers and key number may be required when ordering replacement parts. You may record these numbers in the Quick Reference section at the rear of this manual.

The VIN (1) is stamped on the front of the frame.

FRONT

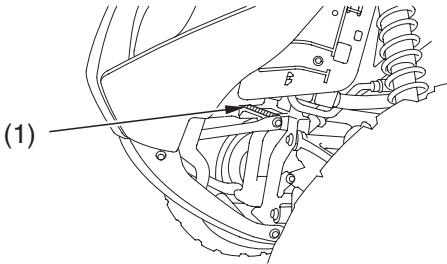

(1) VIN

The engine number (2) is stamped on the upper side of the rear crankcase.

RIGHT SIDE

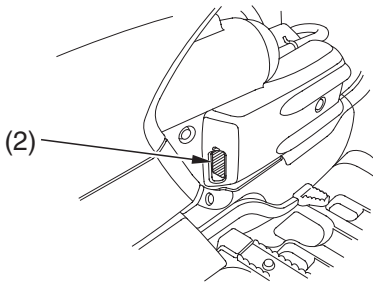

(2) engine number

Vehicle Identification

Color Label & Code

The color label (1) is attached to the frame under the seat. Remove the seat (page 140) to check the label.

The color code is helpful when ordering replacement parts. You may record the color and code in the Quick Reference section at the rear of this manual.

UNDER SEAT

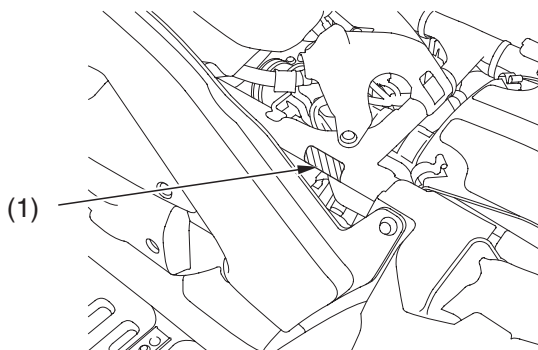

(1) color label

Specifications

Dimensions	
overall length	83.2 in (2,113 mm)
overall width	46.8 in (1,189 mm)
overall height	47.5 in (1,207 mm)
wheelbase	50.7 in (1,289 mm)
ground clearance	9.2 in (234 mm)

Fuel & Lubricants	
fuel recommendation	unleaded gasoline, pump octane number of 86 or higher
fuel tank capacity	4.49 US gal (17.0 ℓ)
engine oil capacity	after disassembly: 4.3 US qt (4.1 ℓ) after draining: 2.9 US qt (2.7 ℓ)
engine oil recommendation	API Service Classification SG or higher except oils labeled as energy conserving on the circular API service label, SAE 10W-30, JASO T 903 standard MA, Pro Honda GN4 or HP4 (without molybdenum additives) 4-stroke oil (USA & Canada) or Honda 4-stroke oil (Canada only), or an equivalent motorcycle oil

Specifications

Fuel & Lubricants (cont'd)	
cooling system recommendation	Pro Honda HP Coolant or an equivalent high quality ethylene glycol antifreeze containing corrosion protection inhibitors specifically recommended for use in aluminum engines
cooling system capacity	2.1 US qt (2.0 ℓ)

Capacities	
passenger capacity	operator only
maximum weight capacity	485 lbs (220 kg) rider, all cargo and accessories

Engine Specifications	
displacement	41.17 cu-in (674.9 cm ³)
bore & stroke	4.02 × 3.25 in (102.0 × 82.6 mm)
compression ratio	9.2 : 1
spark plug (standard)	IFR5L11 (NGK) or VK16PRZ11 (DENSO)
spark plug (high speed riding)	IFR6L11 (NGK) or VK20PRZ11 (DENSO)
spark plug gap	0.039 – 0.043 in (1.00 – 1.10 mm)
valve clearance (cold)	intake: 0.006 in (0.15 mm) exhaust: 0.013 in (0.33 mm)
idle speed	1,400 ± 50 rpm

Specifications

Power Transmission		
primary reduction		1.333
secondary reduction	forward	2.000
	reverse	2.375
final reduction	front	3.231
	rear	3.154
transmission ratio	1st	2.053
	2nd	1.375
	3rd	0.933
	reverse	2.138
final drive		shaft

Chassis & Suspension		
caster		1.6°
trail		0.08 in (2.1 mm)
tire size, front		AT25 × 8R12 ★★ DUNLOP KT511
tire size, rear		AT25 × 10R12 ★★ DUNLOP KT515
tire pressure, front & rear (cold)	front	4.4 psi (30 kPa , 0.30 kgf/cm ²)
	rear	3.6 psi (25 kPa , 0.25 kgf/cm ²)
maximum tire pressure, front & rear (cold)	front	5.0 psi (34 kPa , 0.34 kgf/cm ²)
	rear	4.0 psi (28 kPa , 0.28 kgf/cm ²)
minimum tire pressure, front & rear (cold)	front	3.8 psi (26 kPa , 0.26 kgf/cm ²)
	rear	3.2 psi (22 kPa , 0.22 kgf/cm ²)

Specifications

Electrical	
battery	12 V – 18 Ah
generator	0.36 kW/5,000 rpm

Lights	
headlight	12 V 40/40 W × 2
brake/tail light	12 V 21/5 W × 2
neutral indicator	LED
reverse indicator	LED
high oil/coolant temperature indicator	LED
PGM-FI indicator	LED
4WD indicator	LED

Fuses	
main 1	30 A
main 2	30 A
other	15 A × 1, 10 A × 4

Torque Specification	
engine oil drain bolt	18 lbf·ft (25 N·m , 2.5 kgf·m)
engine oil filter bolt	13 lbf·ft (18 N·m , 1.8 kgf·m)
rear final gear case oil drain bolt	9 lbf·ft (12 N·m , 1.2 kgf·m)
differential oil drain bolt	9 lbf·ft (12 N·m , 1.2 kgf·m)
wheel nuts	47 lbf·ft (64 N·m , 6.5 kgf·m)

Break-in Guidelines

Help assure your ATV's future reliability and performance by paying extra attention to how you ride during the first operating day or 15 miles (25 km).

During this period, avoid full-throttle starts and rapid acceleration.

Emission Control Systems

Exhaust Emission Requirements (USA only)

The U.S. Environmental Protection Agency (EPA) and the California Air Resources Board (CARB) require that your ATV comply with applicable exhaust emission standards during its useful life, when operated and maintained according to the instructions provided.

The Vehicle Emission Control Information Label (1) is attached on the rear fender below the seat.

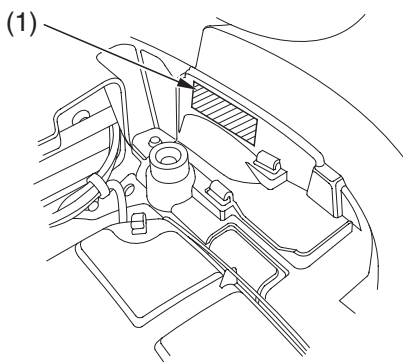

(1) vehicle emission control information label

Emission Control Systems

Source of Exhaust Emissions

The combustion process produces carbon monoxide (CO), oxides of nitrogen (NO_x) and hydrocarbons (HC). Control of hydrocarbons and oxides of nitrogen is very important because, under certain conditions, they react to form photochemical smog when subjected to sunlight. Carbon monoxide does not react in the same way, but it is toxic.

Honda Motor Co., Ltd. utilizes various systems to reduce carbon monoxide, oxides of nitrogen and hydrocarbons.

Exhaust Emission Control System

The exhaust emission control system includes a PGM-FI system. No adjustment to this systems should be made although periodic inspection of the components is recommended.

The exhaust emission control system is separate from the crankcase emission control system.

Crankcase Emission Control System

The engine is equipped with a closed crankcase system to prevent discharging crankcase emissions into the atmosphere. Blow-by gas is returned to the combustion chamber through the air cleaner.

Emission Control Systems

Problems That May Affect ATV Exhaust Emissions

If you are aware of any of the following symptoms, have the vehicle inspected and repaired by your Honda ATV dealer.

Symptoms:

1. Hard starting or stalling after starting
2. Rough idle
3. Misfiring or backfiring during acceleration
4. After-burning (backfiring)
5. Poor performance (driveability) and poor fuel economy

Federal regulations prohibit removing or disabling a device or element of design that may affect your engine's emission performance unless your ATV will be used exclusively in competition. If you modify your engine for use in sanctioned competition events, you must deface or destroy the emission control information label.

Emission Control Systems

Noise Emission Control System

TAMPERING WITH THE NOISE CONTROL SYSTEM IS PROHIBITED:

State laws prohibit, or Canadian provincial laws may prohibit the following acts or the causing thereof: (1) The removal or rendering inoperative by any person, other than for purposes of maintenance, repair or replacement, of any device or element of design incorporated into any new vehicle for the purpose of noise control prior to its sale or delivery to the ultimate purchaser or while it is in use; or (2) the use of the vehicle after such device or element of design has been removed or rendered inoperative by any person.

AMONG THOSE ACTS PRESUMED TO CONSTITUTE TAMPERING ARE THE FOLLOWING ACTS:

1. Removal of, or puncturing the muffler, baffles, header pipes or any other component which conducts exhaust gases.
2. Removal of, or puncturing of any part of the intake system.
3. Lack of proper maintenance.
4. Replacing any moving parts of the vehicle, or parts of the exhaust or intake system, with parts other than those specified by the manufacturer.

Oxygenated Fuels

Some conventional gasolines are being blended with alcohol or an ether compound. These gasolines are collectively referred to as oxygenated fuels. To meet clean air standards, some areas of the United States and Canada use oxygenated fuels to help reduce emissions.

If you use an oxygenated fuel, be sure it is unleaded and meets the minimum octane rating requirement.

Before using an oxygenated fuel, try to confirm the fuel's contents.

Some states/provinces require this information to be posted on the pump.

The following are the EPA-approved percentages of oxygenates:

ETHANOL (ethyl or grain alcohol) 10% by volume

You may use gasoline containing up to 10% ethanol by volume.

Gasoline containing ethanol may be marketed under the name "Gasohol".

MTBE (Methyl Tertiary Butyl Ether) 15% by Volume

You may use gasoline containing up to 15% MTBE by volume.

METHANOL (methyl or wood alcohol) 5% by Volume

You may use gasoline containing methanol containing up to 5%

methanol by volume as long as it also contains cosolvents and corrosion inhibitors to protect the fuel system. Gasoline containing more than 5% methanol by volume may cause starting and/or performance problems. It may also damage metal, rubber, and plastic parts of your fuel system.

Oxygenated Fuels

If you notice any undesirable operating symptoms, try another service station or switch to another brand of gasoline.

Fuel system damage or performance problems resulting from the use of an oxygenated fuel containing more than the percentages of oxygenates mentioned above are not covered under warranty.

Oxygenated fuels can damage paint and plastic. Be careful not to spill fuel when filling the fuel tank. Wipe up any spills immediately.

NOTICE

Oxygenated fuels can damage paint and plastic. Damage caused by spilled fuel is not covered by warranty.

Consumer Information

This section contains information on your warranty and how to get an official Honda service manual.

Authorized Manuals	248
Warranty Coverage	251
Warranty Service.....	252
Contacting Honda	253
Your Honda Dealer	254
The Honda Rider's Club (USA only).....	255

Authorized Manuals

The Service Manual used by your authorized Honda dealer is available from Helm, Inc. (USA only, Canada: See your Honda dealer to order authorized manuals.)

Also available but not necessary to service your model is the Honda Common Service Manual which explains theory of operation and basic service information for various systems common to all Honda motorcycles, motor scooters and ATVs.

These Honda manuals are written for the professional technician, but most mechanically-capable owners should find them easy to use if they have the proper tools and observe proper safety standards. Special Honda tools are necessary for some procedures.

Publication Item No.	Description	Price Each*
61HN851	2007 TRX680FA/FGA RINCON Service Manual	\$48.00
61CM002	Common Service Manual	\$48.00
31HN8640	2007 TRX680FA/FGA RINCON Owner's Manual	\$16.00

** Prices are subject to change without notice and without incurring obligation.*

Order On-Line: www.helminc.com

Order Toll Free: 1-888-CYCLE93 (1-888-292-5393)

(NOTE: For Credit Card Orders Only)

Monday — Friday 8:00 AM — 6:00 PM EST

OR

By completing this form you can order the materials desired. You can pay by check or money order, or charge to your credit card. Mail to Helm, Inc. at the address shown on the back of this order form (USA only).

Canada: See your Honda dealer to order authorized manuals.

Publication Item No.	Item Description	Qty.	Price Each*	Total Price
*Prices are subject to change without notice and without incurring obligation. Orders are mailed within 10 days. Please allow adequate time for delivery.		Sub Total		
		Purchaser's Sales Tax		
		Mich. Add 6 %		
		Calif. Add 8.25 %		
		Handling Charge		\$5.00
		Grand Total		

S
H
I
P
T
O

NOTE: Dealers and Companies please provide dealer or company name, and also the name of the person to whose attention the shipment should be sent.

Customer Name _____

Attention _____

Street Address _____ Apartment Number _____

City _____ State _____ Zip Code _____

Daytime Telephone Number () _____

P
A
Y
M
E
N
T

Check or money order enclosed payable to Helm Inc. U. S. funds only. Do not send cash.

Check here if your billing address is different from the shipping address shown above.

VISA MasterCard Discover

Account Number

Expiration: Mo. Yr.

Customer Signature _____ Date _____

These Publications cannot be returned for credit without receiving advance authorization within 14 days of delivery. On returns, a restocking fee may be applied against the original order.

HELM P. O. BOX 07280, DETROIT, MICHIGAN 48207

Warranty Coverage

Your new Honda is covered by these warranties:

- TRX Limited Warranty
- Exhaust Emission Warranty (USA Only)

There are responsibilities, restrictions, and exclusions which apply to these warranties. Please read the Warranties Booklet given to you by your Honda dealer at the time of purchase. Be sure to keep your Honda owner's card with your Warranties Booklet (USA only).

It is important to realize that your warranty applies to defects in material or workmanship of your Honda. Your warranty coverage does not apply to normal wear or deterioration associated with using the ATV.

Your warranty coverage will not be voided if you choose to perform your own maintenance. However, you should have the proper tools and service information and be mechanically qualified. Failures that occur due directly to improper maintenance are not covered.

Almost all of your warranty coverage can be extended through the Honda Protection Plan (USA only). For more information, see your Honda dealer.

Warranty Service

Please remember that recommended maintenance interval servicing is not included in your warranty coverage. Additionally, your warranty does not apply to the normal wear of items (such as brakes, tires, etc.).

If you believe you have a problem with your ATV, call the service department of your Honda dealer. Make an appointment for an inspection and diagnosis. Remember, as the owner of the ATV, you will be asked to authorize that inspection. Your dealer will give you the results of the inspection. If the problem is covered under warranty, your dealer will perform the warranty repairs for you.

If you have questions about warranty coverage or the nature of the repair, it is best to talk to the service manager of your Honda dealer.

Sometimes, in spite of the best intentions of all concerned, a misunderstanding may occur. If you aren't satisfied with your dealer's handling of the situation, we suggest you discuss your problem with the appropriate member of the dealership's management team. If the problem has already been reviewed with the Service Manager, Parts Manager, Sales Manager, etc., contact the Owner of the dealership or their designated representative.

Contacting Honda

Your owner's manual was written to cover most of the questions you might ask about your Honda. Any questions not answered in the owner's manual can be answered by your Honda dealer. If your dealer doesn't have the answer right away, they will get it for you.

If you have a difference of opinion with your dealer, please remember that each dealership is independently owned and operated. That's why it's important to work to resolve any differences at the dealership level.

If you wish to comment on your experiences with your Honda or with your dealer, please send your comments to the following address (USA only):

Motorcycle Division, American Honda Motor Co., Inc., P.O. Box 2220, Torrance, CA 90509-2220, mailstop: 100-4C-7B, telephone: (866) 784-1870.

Canada: Refer to the Warranties Booklet that was supplied with your vehicle.

Please include the following information in your letter:

- name, address, and telephone number
- product model, year, and VIN
- date of purchase
- dealer name and address

We will likely ask your Honda dealer to respond, or possibly acknowledge your comments directly.

Your Honda Dealer

Once you purchase your new Honda, get familiar with the organization of your Honda dealer so you can utilize the full range of services available.

The service department is there to perform regular maintenance and unexpected repairs. It has the latest available service information from Honda. The service department will also handle warranty inspections and repairs.

The parts department offers Genuine Honda parts, Pro Honda products, Hondaline accessories (USA only), and Honda accessories and products (Canada only). The same quality that went into your Honda can be found in Genuine Honda replacement parts. You'll also find comparable quality in the accessories and products available from the parts department.

The sales department offers the Honda Protection Plan to extend almost all of your warranty coverage (USA only).

Your Honda dealer can inform you about competition and other riding events in your area. You'll also find that your dealer is a source of information about American Honda's Rider Education Centers and the Honda Rider's Club of America (USA only).

We're sure you'll be as pleased with the service your Honda dealer continues to provide after the sale as you are with the quality and dependability of your Honda.

The Honda Rider's Club (USA only)

One of the best ways to get the most enjoyment from owning and riding your Honda is through the Honda Rider's Club of America. Your purchase of a new motorcycle, scooter, ATV or PWC from a participating U.S. Honda dealer entitles you to a complimentary one-year membership in the Club. There are hundreds of HRCA Chapter-sponsoring dealers across the USA with events and activities almost every weekend. Membership benefits include:

- 24-hour, toll-free roadside assistance for your new Honda (includes roadside assistance for your transport vehicle [up to one ton] as long as your Honda is aboard or in tow). *For street-legal motorcycles and scooters only.*
- An exclusive HRCA website complete with access to the official Honda Common Service Manual, contests, insider information and more.
- Reimbursement (up to \$75) for successful completion of a Motorcycle Safety Foundation training course. Separate, complimentary training from the Specialty Vehicle Institute of America for purchasers of new ATVs.
- One full year of *Honda Red Rider* magazine (six issues).
- Discounts from HRCA partners for experienced rider courses.
- Discounted vehicle insurance from the HRCA's insurance partner.
- Racing contingency programs and assistance at selected dual-sport, off-road and motocross events for off-road motorcycles and selected ATVs.

If you purchased an off-road motorcycle, ATV or PWC, your benefits do not include roadside assistance or trip interruption protection.

Contact your Honda dealer for more information or call: 1-800-847-4722 or log on to www.hrca.honda.com.

Table of Contents

The following presents the contents of each section of your owner's manual.

ATV SAFETY	1
Important Safety Information	2
Safety Labels.....	5
INSTRUMENTS & CONTROLS.....	9
Operation Component Locations	11
Indicators & Displays.....	14
Multi-function Display.....	19
Drive Mode Indicator.....	20
Gear Position Indicator.....	21
Oil Change Indicator.....	22
Odometer.....	23
Tripmeter.....	23
Hourmeter	25
Digital Clock	26
Fuel Gauge.....	29
Controls & Features	30
Ignition Switch.....	30
Shift Lever	31
Drive Mode Select Switch.....	32
2WD/4WD Select Switch	33
Start Button	34
Engine Stop Switch.....	34
Headlight Switch.....	35
Headlight Dimmer Switch.....	35
Recoil Starter.....	36
Throttle lever.....	37
Gear Shift Switch.....	38

Table of Contents

Front Brake Lever	39
Rear Brake Lever	39
Rear Brake Pedal.....	39
Parking Brake.....	40
Flag Pole Bracket	41
Accessory Socket	42
GPSScape system (TRX680FGA only).....	45
Introduction.....	46
Important Safety Information	49
System Limitations.....	50
System Start-up	51
Position Fix	51
System Failure to Display a Position Fix	52
Satellite Status	54
GPS Mode	56
GPS Mode Display.....	58
Waypoint Number Display	59
Direction to Waypoint Display	60
Distance to Waypoint	62
Basic Waypoint Selection	63
Advanced Waypoint Selection.....	65
Determining the Coordinates of Your Current Position.....	69
Compass Direction Indicator.....	70
Automatic Clock Adjustment.....	72

Table of Contents

BEFORE RIDING	73
Are You Ready to Ride ?	74
Protective Apparel.....	74
Rider Training.....	76
Age Recommendation.....	77
No Passengers	77
No Alcohol or Drugs.....	78
Is Your ATV Ready to Ride ?.....	79
Pre-ride Inspection	79
Load Limits & Guidelines.....	83
Loading	83
Cargo And Trailer Information	84
Loading Guidelines	86
Accessories & Modifications	87
Accessories.....	87
Modifications	88

Table of Contents

BASIC OPERATION & RIDING	89
Safe Riding Precautions	91
Off-Road Use Only	91
Keep Hands and Feet on Controls.....	92
Control Speed.....	93
Use care on Unfamiliar or Rough Terrain.....	94
Do Not Perform Stunts.....	95
Starting & Stopping the Engine	96
Preparation	96
Starting Procedure.....	97
Flooded Engine	98
Bank Angle Sensor Ignition Cut-off System	98
Stalled Engine	99
How to Stop the Engine	100
Using the Recoil Starter	101
Shifting Gears	102
Riding in Reverse.....	108

(cont'd)

Table of Contents

Braking.....	110
Riding Your ATV	112
Making Turns.....	112
Skidding or Sliding	114
Riding Up Hills	115
Riding Down Hills	119
Crossing or Turning on Hills or Slopes.....	120
Riding Over Obstacles	122
Riding Through Water	123
Parking	124

Table of Contents

SERVICING YOUR HONDA.....	125
<i>Before You Service Your Honda</i>	
The Importance of Maintenance	127
Maintenance Safety	128
Important Safety Precautions	129
Maintenance Schedule	130
Maintenance Record.....	134
 <i>Service Preparations</i>	
Maintenance Component Locations	135
Tool Kit.....	138
Owner's Manual Storage.....	139
Seat Removal	140
 <i>Service Procedures</i>	
<u>Fluids & Filters</u>	
Fuel	141
Engine Oil & Filter.....	144
Gear Case Oil	152
Differential Oil.....	154
Coolant.....	156
Air Cleaner.....	161
 <u>Engine</u>	
Throttle.....	166
Spark Plug	168
Valves.....	171
Spark Arrester	172

(cont'd)

Table of Contents

Chassis

Brakes.....	174
Tires	182
Engine Guard & Skid Plate	189
Driveshaft Boots	190

Electrical

Battery	191
---------------	-----

Appearance Care	196
-----------------------	-----

TIPS..... 201

Preparing for a Ride	202
What to Take to The Riding Area	202
What to Take on The Trail	203
Transporting Your Honda	204
Storing Your Honda	206
You & the Environment	210

TAKING CARE OF THE UNEXPECTED..... 211

General Guidelines	212
If Your Engine Quits or Won't Start.....	215
If the Transmission Is Not Functioning Properly	217
If You Have a Flat Tire	219
If the High Oil/Coolant Temperature Indicator Lights	222
If a Fuse Blows	224
If You Crash.....	228
If You Lose Your Key	229
If the Battery Is Low (or Dead).....	230
If a Component Fails.....	231

Table of Contents

TECHNICAL INFORMATION	233
Vehicle Identification.....	234
Specifications.....	236
Break-in Guidelines	240
Emission Control Systems.....	241
Oxygenated Fuels.....	245
CONSUMER INFORMATION	247
Authorized Manuals	248
Warranty Coverage	251
Warranty Service.....	252
Contacting Honda	253
Your Honda Dealer	254
The Honda Rider's Club (USA only).....	255
TABLE OF CONTENTS	256
INDEX	264
QUICK REFERENCE	

Index

A

accessories.....	86
accessory socket.....	42
age recommendation	77
air cleaner,	
filter.....	161
housing drain tube.....	165
air pressure,	
gauge.....	139
tire	183
American Honda, contacting.....	253
apparel,protective.....	74
appearance care	196
authorized manuals.....	248

B

Battery.....	191
Bank angle sensor ignition cut-off system.....	98
Brakes,	
cables.....	180
fluid.....	174
front brake lever.....	39
pad wear	177
parking	40
rear brake lever.....	39
rear brake lever freeplay	179
rear brake pedal.....	39

Index

braking	110
break-in guidelines	240
button,	
ADJ	26
digital clock / hourmeter select	26
GPS / WP	57
hour select	26
minus	27, 59
minute select.....	26
odometer / tripmeter select.....	23
plus	27, 59
RESET	24

C

capacity, fuel.....	142
care, appearance	196
cargo,	
Loading and operational guidelines	86
Weight limit	85
climbing hills.....	115
color label.....	235
compartment,	
owner's manual	139
tool kit	138
component fails.....	231
consumer information	247
crash, if you.....	228
crossing or turning on hills or slopes	120
customer service.....	253

Index

D

differential oil	154
digital clock.....	26
digital clock / hourmeter select button	25
dimmer switch,headlight	35
dipstick	147
display, multi-function	19
driveshaft boots.....	190
drive mode indicator	20
drive mode select switch	32

E

emission control system	241
engine	
flooded	98
guard	189
number	234
oil	144
pinging	141
starting.....	96
stop switch.....	34
stopping	100
won't start	215
environment	210

Index

F

final gear case oil	152
flag pole bracket.....	41
flat tire.....	219
flooded engine.....	98
fuel,	
fill cap	142
gauge.....	29
oxygenated	245
recommendation.....	141
tank capacity	142
fuses	224

G

gap, spark plug	169
gasohol	245
gasoline	141
gear case oil.....	152
gear shifting	102
GPS mode display	58
GPS/WP button	18, 57

Index

H

headlight dimmer switch	35
headlight switch	35
hills,	
crossing or turning on slopes	120
riding down hills	119
riding up hills	115
stopping on hills	117
Honda,	
contacting	253
Rider's Club	255
dealer	254
hourmeter	25
hour select button	25
Honda service manual	248

Index

I

identification, vehicle.....	234
ignition switch.....	30
indicators	
drive mode indicator	20
gear position indicator	21
high oil/coolant temperature indicator	16
neutral indicator	17
oil change indicator.....	22
PGM-FI indicator	18
reverse indicator	16
4WD indicator.....	16, 33
inspection, pre-ride.....	79

K

key, lost	229
kit, tool	138

Index

L

labels, safety.....	5
lamp check	15
limit, weight	85
loading guidelines	86
longitude.....	47
lubrication	
engine oil.....	144
differential oil	154
gear case oil.....	152

M

maintenance,	
importance.....	127
precautions	129
record	134
safety.....	128
schedule.....	130
manual, service.....	248
maximum weight limit	85
minus button.....	27, 65
modifications.....	88
multi-function display	19

Index

N

neutral indicator	17
noise emission control systems	244
numbers, serial	234

O

obstacles, riding over	122
odometer.....	23
odometer/ tripmeter select button.....	23
oil,	
differential.....	154
engine.....	144
gear case.....	152
oil/coolant temperature indicator	14, 222
owner's manual storage.....	139
oxygenated fuels	245

Index

P

parking	124
passenger, no carrying.....	77
pavement, no riding on.....	91
pinging, engine.....	141
plug, spark.....	168
plus button.....	27, 65
pre-ride inspection.....	79
problems, unexpected.....	211
protective apparel.....	74

R

rear final gear case oil.....	152
recoil starter.....	36
removal, seat	140
reverse,	
gear, shifting into	108
indicator	16
riding in	108
rider training.....	76
Rider's Club, Honda.....	255

Index

riding,	
basic operations	89
clothing	74
precautions	91
preparing for	202
over obstacles	122
safety	2
safety precautions	91
through water	123

S

safety,	
important precautions	129
labels	5
riding precautions	91
schedule, maintenance	132
seat removal	140
serial numbers	234
service,	
customer	253
manuals	248
warranty	252

(cont'd)

Index

shifting gears	102
shifting lever	31
skid plate	189
skidding or sliding	114
spark arrester	172
spark knock	141
spark plug	168
specifications	236
speedometer	17
stalling on a hill	117
start button	34
starting,	
engine	96
troubleshooting	215
stop switch, engine	34
stopping engine	100
storage,	
ATV	206
owner's manual	139
switch,	
headlight	35
headlight dimmer	35
ignition	30
2WD/4WD select	33

Index

T

throttle	
cable	166
lever.....	37, 166
tires,	
air pressure	183
flat	219
replacing	188
repairing	187
thread conditions	185
tool kit	138
trailer towing	
operational guidelines	86
weight limits.....	85
training, rider.....	76
transporting your ATV.....	204
tripmeter	23
trouble, unexpected	213
troubleshooting, starting.....	215
turning,	
on level ground.....	112
on hills or slopes.....	120

V

valve clearance	171
vehicle identification no. (VIN).....	234

Index

W

warning labels	5
warranty,	
coverage	251
extended	251
service	252
washing your ATV	197
water,	
riding through.....	123
weight limit	85
wheel removal	220

Quick Reference

The following is a brief, but important collection of information you need to know about your Honda. You'll also find space to record important notes.

How To Avoid Costly Repairs

The engine of your Honda can be the most expensive component to repair. Proper maintenance, especially the use of the recommended fluids and filters, prevents premature wear and damage.

Frequent causes of costly repairs are:

- Engine oil: insufficient quantity, improper oil.
- Air cleaner: dirty, leaking because of improper installation (poor seal).

Record important information on the following page:

Quick Reference

Engine No.	
VIN	
Ignition Key No.	
Color Label	
Owner's Name	
Address	
City/State	
Phone	
Dealer's Name	
Address	
City/State	
Phone	
Service Mgr.	

Quick Reference

Scheduled Maintenance	Initial: 100 miles (150 km) Regular: every 600 miles (1,000 km)
Pre-ride Inspection	Check the following items each time before you ride (page 79): engine oil, radiator coolant, fuel, tires, driveshaft boots, nuts & bolts, underbody & exhaust system, air cleaner housing drain tube, leaks, loose parts, cables, lights, throttle, brakes, switches, steering.
Fuel/Capacity	unleaded gasoline, pump octane number 86 or higher 4.49 US gal (17.0 ℓ)
Engine Oil	API Service Classification SG or higher except oils labeled as energy conserving on the circular API service label, SAE 10W-30, JASO T 903 standard MA, Pro Honda GN4 or HP4 (without molybdenum additives) 4-stroke oil or equivalent
Maximum Weight Capacity	485 lbs (220 kg) rider, all cargo and accessories

Quick Reference

Tires	Front: AT25 × 8R12 ★★ DUNLOP KT511 Rear: AT25 × 10R12 ★★ DUNLOP KT515
Tire Pressure (cold)	Front: 4.4 psi (30 kPa , 0.30 kgf/cm ²) Rear: 3.6 psi (25 kPa , 0.25 kgf/cm ²) maximum tire pressure: Front: 5.0 psi (34 kPa , 0.34 kgf/cm ²) Rear: 4.0 psi (28 kPa , 0.28 kgf/cm ²) minimum tire pressure: Front: 3.8 psi (26 kPa , 0.26 kgf/cm ²) Rear: 3.2 psi (22 kPa , 0.22 kgf/cm ²)
Spark Plugs	standard: IFR5L11 (NGK) or VK16PRZ11 (DENSO) high speed riding: IFR6L11 (NGK) or VK20PRZ11 (DENSO)
Coolant	ethylene glycol antifreeze (silicate-free) for aluminum engines in 50/50 solution with Pro Honda HP Coolant or an equivalent distilled water
Fuses	main 1: 30 A main 2: 30 A others: 15 A × 1, 10 A × 4